

Planning Manual

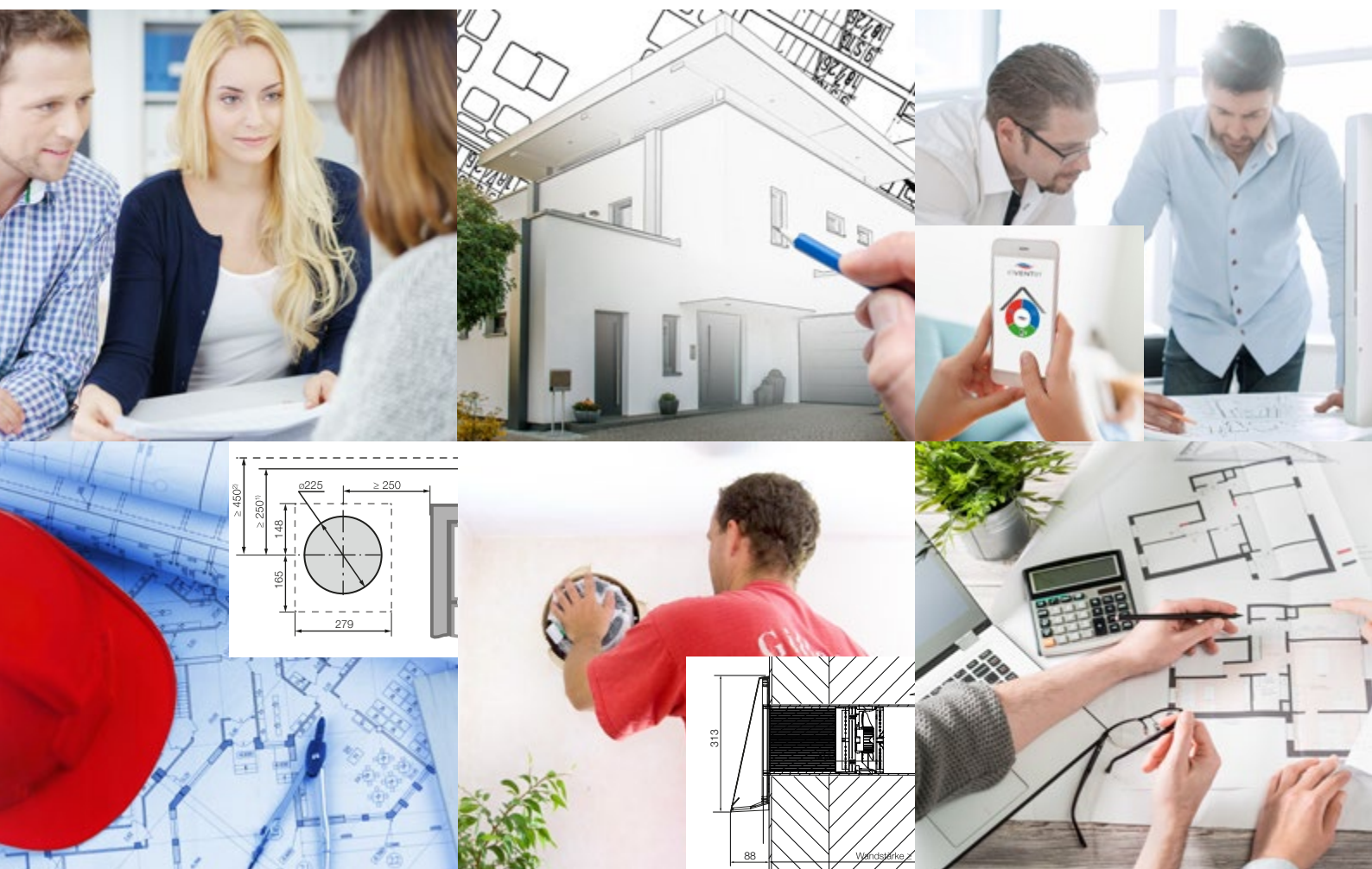



inVENTer

Planning Manual

Decentralised Residential Ventilation

Disclaimer

The content of this planning manual has been carefully checked for compliance with the hardware and software described. Nevertheless, deviations, e.g. changes or in the meantime omission of components, cannot be excluded due to constant further development of our products, so that no guarantee can be assumed for complete conformity and freedom from errors.

Statements about equipment and features are non-binding. The equipment features described in this planning manual are not considered to be the agreed quality of our products. For information on the products and product features currently available, please contact your local factory representative.

This documentation is updated regularly. Necessary corrections and appropriate supplements are always included in the following releases. You can also find the latest edition of the planning manual and current tender texts at www.inventer.de/downloads.

On request, we will be pleased to provide you with our inVENTer calculation tool for dimensioning.

All illustrations in the planning manual are only examples of applications. The illustrations and texts also contain components and accessories and special equipment which are not part of the standard scope of delivery.

In addition, always observe the regional regulatory stipulations. These may deviate completely or partially from the specifications given in this planning manual. In this case, the official stipulations always apply.

Technical specifications

Unless otherwise stated, dimensions in illustrations are in millimetres. All technical specifications refer to new devices with clean heat accumulators. The technical specifications correspond to the norms and standards valid at the time of writing of this planning manual. A change of these standards or technical specifications due to component changes is possible at any time. This is checked regularly and taken into account in subsequent versions.

Table of Contents

	Page
Information for controlled ventilation of residential spaces	
Controlled ventilation of residential spaces	6
Function	8
Decentralised ventilation planning standards	10
Ventilation according to DIN 1946-6	11
Technical specifications	
Overview	14
Standard sound level difference + assessed sound insulation factor	24
Assembly and installation tools	28
iV ventilation systems with heat recovery	
inVENTer iV-Smart+	36
inVENTer iV-Smart+ Corner	38
inVENTer iV-Smart+ Nordic	40
inVENTer iV-Smart+ SyIt	42
inVENTer iV-Smart+ Top	44
inVENTer iV14-Zero	46
inVENTer iV14-Zero Corner	48
inVENTer iV14-Zero Nordic	50
inVENTer iV-Twin+	52
inVENTer iV-Twin+ Corner	54
inVENTer iV-Twin+ Nordic	56
inVENTer iV-Light	58
inVENTer iV-Compact	60
inVENTer iV-Office	62
inVENTer iV14-MaxAir	64
inVENTer iV14-MaxAir Corner	66
inVENTer iV14-MaxAir Nordic	68
inVENTer PAX (central residential ventilation)	70
X-Flow (single-room ventilation)	74
USTS 100 Pulsar overflow system	76
Controller for inVENTer ventilation systems	
sMove controller	80
inVENTer Connect controller platform	82
Installation diagrams ventilation systems with IB Connect	92
MZ-Home controller	99
aV exhaust air systems without heat recovery	
aV100 wall mounting kit	104
Pulsar Basic exhaust air system	106
Pulsar exhaust air unit	107
Aviant exhaust air unit	108
Avio N 100 exhaust air unit	109
Taris exhaust air unit	110
aV100 ALD, Plus, Corner, Nordic air inlets	114
aV160 ALD Light, Plus, Corner, Nordic air inlets	118
aV200 ALD, Corner, Nordic air inlets	122
Accessories for inVENTer products	126
Warranty overview	130



Information

for controlled ventilation of residential spaces



Controlled ventilation of residential spaces

For you, energy saving begins with the investment in good facade insulation, tight windows and tight doors in order to use heating energy efficiently and reduce energy consumption.

The resulting sealed construction of the buildings does not only have advantages. Insulation in new buildings and also in renovated old buildings increasingly leads to damage in the building substance, as the buildings can no longer "breathe" properly. In addition to a poor indoor climate, high-density building claddings can also lead to mould growth.



An automatic ventilation system, e.g. from inVENTer, which automatically removes used air and supplies fresh air, ensures a healthy indoor climate. Thanks to the high heat recovery and low energy consumption, with the decentralised ventilation systems you can efficiently save valuable heating energy.

And even if there is no obvious mould growth or moisture damage, poor ventilation can still cause discomfort. Occupants present produce carbon dioxide, which must be removed and replaced by oxygen. Good air quality requires a continuous air exchange of 30 m³ per hour per person. A constant exchange of air is important because an excessively high CO₂ concentration can cause disorders such as poor concentration and headaches.

Used air not only reduces your performance, it is also bad for your health and well-being.

Decentralised ventilation systems

We often take the indoor climate at home or at work for granted. Although temperatures that are too high or too low are still consciously perceived, subjective perception is often not sufficient as an evaluation criterion even for humidity.

Conventional window ventilation is often intended to provide a remedy here. But due to the stronger building insulation, this too is increasingly reaching its limits and in many cases is no longer sufficient. Decentralised systems for domestic ventilation offer a flexible alternative.



Reliable and proven effectiveness

Decentralised ventilation units, also known as alternating systems, are the most common form of decentralised home ventilation. Due to the many advantages in terms of installation, application and low maintenance, the demand for these systems has been rising continuously for years.

The EwWalt study was intended to gather further findings on alternating operation and was able to substantiate the basic functioning of the system. The ventilation efficiency was investigated on the basis of an elaborate simulation and under usual design variants on the basis of a room, an apartment and a single-family house. It was found that in all cases mixed ventilation was used regardless of the size of the room. Therefore, the ventilation effect is equal to other ventilation solutions.

The study illustrates the versatile application possibilities of alternating systems; they can be used effectively both in one room and in several rooms with overflow. The interaction with other floors (e.g. in a single-family house) is also confirmed.



Conventional window ventilation: A landlord cannot prescribe window ventilation because permanent airing is not the usual purpose of an apartment and is unreasonable for the tenant (several court rulings).

Installation in the facade wall

Decentralised ventilation systems can be easily inserted into the exterior wall both for renovations and for new buildings.

If the wall opening has been prepared, the installation per ventilation unit can be completed within less than 2 hours. There is no need to install ducts or take special maintenance features into account.

Planning together with experts

Experience has shown that even for planners and architects who have not yet come into contact with decentralised ventilation systems, the design does not present a major obstacle.

In the unlikely event of any ambiguities, our factory representatives and our in-house planning department will support you with practical planning services for the design of decentralised ventilation systems.



Functionality

A decentralised ventilation system is based on supply air movement between corresponding ventilation units. Decentralised ventilation systems combine exhaust and supply air and function according to the transverse ventilation principle. Thanks to the transverse ventilation principle, the air can circulate through the entire residential unit and also adequately ventilate interior living spaces. By specifically influencing air movement, humidity and air quality, the units contribute to structural protection and increased comfort in the living space.

Ventilation units with heat recovery

The decentralised iV ventilation systems with heat recovery consist of ventilation units arranged in pairs. They always work in push-pull mode and automatically switch between exhaust and supply air mode in order to ensure balanced air volume flows.

Quiet as a whisper, your inVENTer ventilation unit's fan turns for 70 seconds in one direction, transporting used air outdoors. The inner ceramic core stores the heat from the air inside. Then, the direction of rotation changes. Fresh air from outside is absorbed, heated in the ceramic heat accumulator and released into the room. Valuable heating energy is used efficiently.

With appropriate inVENTer controllers, you may operate the iV ventilation systems intuitively. Different operating modes or the strength of the ventilation can be set individually. The key components of the iV system are the ceramic heat accumulator, the reversing fan, double air fins for straightening the air volume flow, filters for all hygienic requirements, a lockable inner screen and the powder-coated, rain-proof weather protection hood.

Exhaust air units and air vent openings

Ventilation units with heat recovery can be supplemented with exhaust air units for the ventilation of rooms with moisture ingress (e.g. bathrooms, toilets). They work without heat recovery and can be designed for permanent or demand-driven operation. Humid room air and odours are led outside via the ventilation unit. The additional exhaust air volume flows can be re-circulated via the decentralised units.

Alternatively, an exhaust air system without heat recovery with external air diffusers (ALD) is also possible. The ALD are installed in the supply air room, which forms a room network with the exhaust air unit. The resulting negative pressure causes the outside air to flow in automatically. The external air diffusers are equipped with a filter system to ensure the minimum hygienic requirements and are equipped with a wind protection as standard.

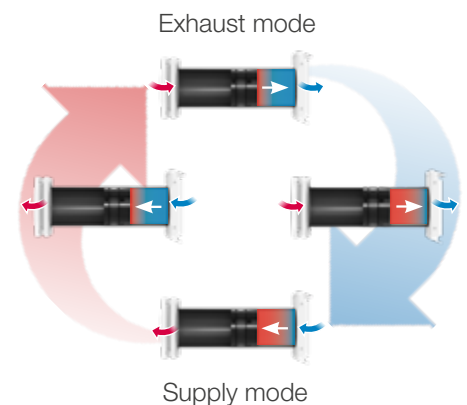

 Exhaust air units complement decentralised ventilation units in damp rooms.

 Exhaust air systems are made up of exhaust air units and external air diffusers

Overflow areas

An air connection between the individual rooms is created by suitable overflow measures within the residential unit. In order to ensure the exchange of air between the respective units, correspondingly large overflow openings must be considered.

The overflow can also be fan-assisted using overflow systems.

Their interaction ensures an optimal comfortable atmosphere in your home.

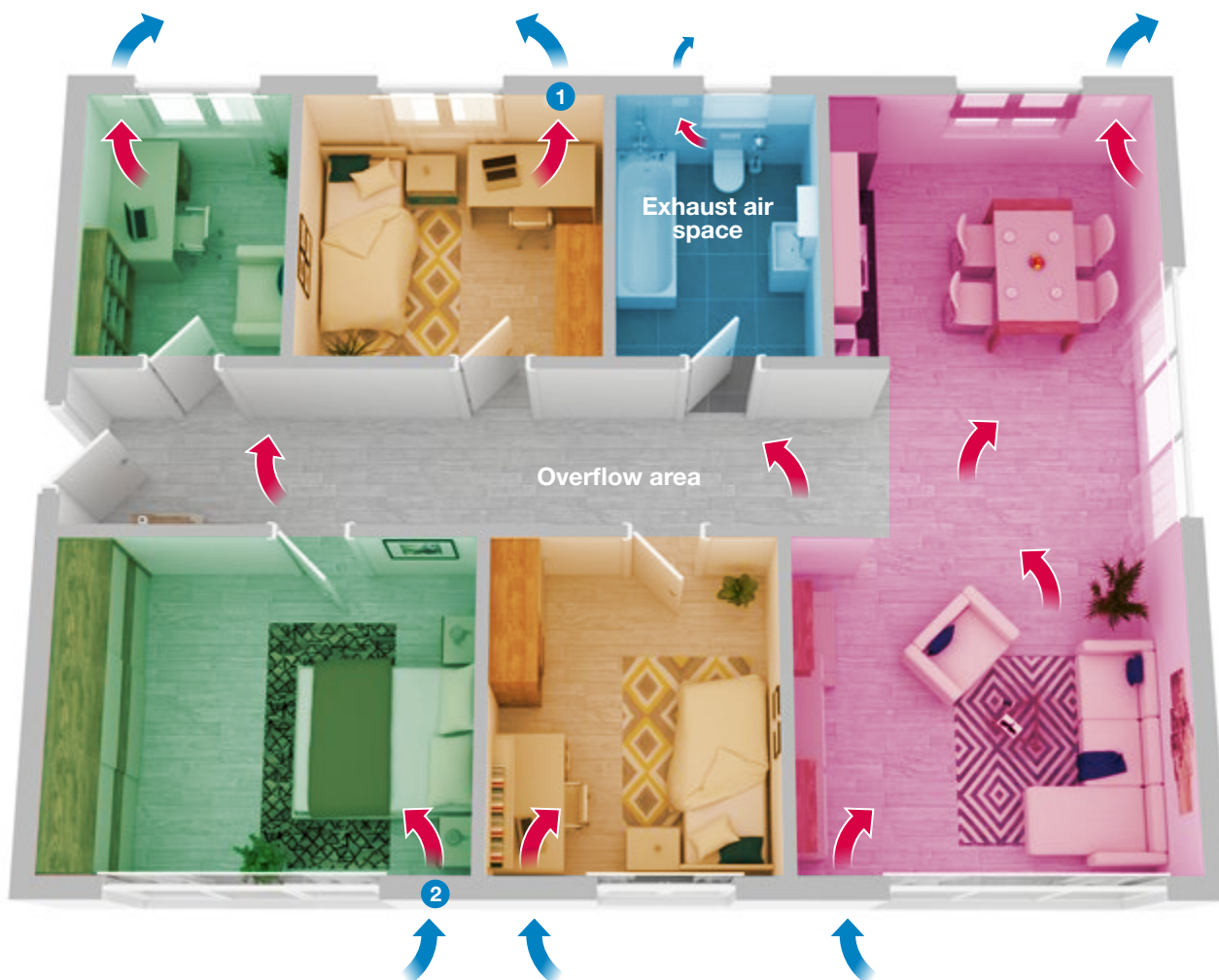

1 Fan in exhaust air mode

2 Fan in air supply mode

Decentralised ventilation planning standards



The standards and regulations listed in this planning manual represent relevant standards and guidelines in the Federal Republic of Germany for the planning of decentralised ventilation systems at the time of publication only and are applicable at the time of printing. The list makes no claim to completeness and validity at a later date.

In addition, always observe the regional official regulations, e.g. the respective state building regulations. These may deviate completely or partially from the specifications given in this planning folder. In this case, the official stipulations always apply.

If outside Germany, observe the application of the respective country-specific standards and regulations.

Ventilation planning regulations

DIN 1946-6:2019-12: Room air technology, ventilation of residences.

DIN 18017-3: Ventilation of windowless kitchens and bathrooms with fans

EN 13142: Room air technology: Ventilation of residences – Required and freely selectable power ratings.

DIN EN ISO 16890-1: Air filters for general ventilation technology - Determination of filter performance.

DIN EN 13141-8: Ventilation of buildings: Performance testing of components/products for residential ventilation.

DIN EN 15665: Ventilation of buildings: Determining performance criteria for residential ventilation systems.

Sound insulation regulations

DIN EN 12102: Measurement of airborne noise – Determination of the sound power level.

EN ISO 10140: Acoustics – Laboratory measurement of sound insulation of building elements.

DIN 4109: Sound insulation in buildings.

Energy saving regulations

GEG: Gebäudeenergiegesetz, Germany's building energy law

DIN EN 12831: Heating systems in buildings – Method for calculating the standard heating load

DIN 4108-6: Thermal insulation and energy saving in buildings

DIN 4108-7: Thermal insulation and energy saving in buildings - Airtightness of buildings, requirements, planning and implementation recommendations.

DIN 4701-10: Energetic evaluation of heating and ventilation systems - heating, potable water heating, ventilation

DIN EN 16789: Energy efficiency of buildings.

Ventilation according to DIN 1946-6



GEG regulations of 1/11/2020

According to the GEG, a building “must be constructed so that the enclosing, heat-transferring surface, including joints, has a permanent, air-tight ... seal. Public-law stipulations governing minimum air exchange for health and heating purposes are not affected by this requirement.” (§ 13) This minimum air exchange can be determined for residential areas, for example, according to DIN 1946-6, which stipulates that for new buildings and energetic building renovation, the necessity of ventilation measures must be determined.

Basically, it can be said that ventilation measures are always necessary when the preservation of the building fabric cannot be covered by avoiding moisture through window ventilation as well as joints and leaks.

For new buildings, a ventilation concept is generally required.

A ventilation concept is required for renovation if:

- in a detached house more than 1/3 of the existing windows are replaced or more than 1/3 of the existing roof area is sealed,
- in an apartment building, more than 1/3 of the existing windows will be replaced.

inVENTer provides a free calculation tool for planning your new building or renovation. Our team supports you with practical planning services for the design and creation of a DIN-compliant ventilation concept.



Air types according to DIN 1946-6

DIN 1946-6 distinguishes between four types of ventilation: Humidity protection ventilation, reduced ventilation, nominal ventilation and intensive ventilation.

In the case of fan-assisted ventilation, e.g. with the aid of inVENTer, however, the design must always be based on nominal ventilation. This takes both the protection of buildings and the hygienic and health requirements of the occupants into account.

Moisture protection ventilation is the basic ventilation to avoid moisture damage depending on the thermal insulation level of the building with partially reduced moisture loads. This level must be ensured constantly and without the participation of the users. If this cannot be guaranteed, a ventilation measure must be taken. The moisture protection ventilation only takes into account the protection of buildings, no hygienic requirements.

Nominal ventilation is the necessary ventilation to guarantee the hygienic and health requirements as well as building protection during normal use of the flat. The user can be consulted for this partly with active window ventilation.

Overview of inVENTer manufacturer's certificate



inVENTer GmbH • Ortsstraße 4a • D-07751 Löberschütz

inVENTer manufacturer's certificate: Characteristic data for energy evaluation

Decentralized Ventilation Unit with Heat Recovery "iV-Smart+"/"iV14-Zero"

- Air Volume Flow**

Air volume flows (qv in m³/h)		
Air volume flow range	Reference flow rate 0,7 x q _{vd}	Maximum air volume flow q _{vd}
17 ≤ q _v ≤ 58 m³/h	42 m³/h	58 m³/h
- Characteristics according to DIN EN 13141-8:2014-09 / VO 1254/2014**

Thermal efficiency (DIN EN 13141-8:2014-09)		Air flow sensitivity to pressure variations (20 Pa)	SEC [kWh/m²a] With local demand control	SEC [kWh/m²a]
Supply air η _{8,SU}	Extract air η _{8,EXH}	Maximum air flow deviation	-43.95	-39.42
0.87	0.83	29.4	A+	A
- Characteristics according to DIN 4701-10:2003-08**

Heat recovery rate η _{WRG}		SPI Specific power input p _{el} in [W/(m³/h)]
η _{WRG}	η _{WRG} (with wall mounting system "Simplex")	
0.78*	0.80**	0.14

Effects of heat loss via the housing have already been taken into account.
* applies to iV-Smart+ without wall mounting system or simplex
** iV14-Zero: always 0.80
- Data source**

DIBt Approval Z-51.3-429 dated 09/12/2019; DiBt Approval Z-51.3-452 dated 28/07/2021; TÜV Süd Test report: WRG 502-rev1 EN 13141-8

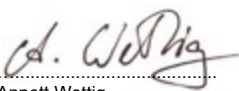

Annett Wettig
CEO

Status: 08/2021

inVENTer GmbH
Ortsstraße 4a
D-07751 Löberschütz

Telefon: +49 (0) 36427 211-0
Telefax: +49 (0) 36427 211-113
E-Mail: info@inventer.de

Geschäftsführerin: Annett Wettig
UST-IdNr.: DEB15494982
Amtsgericht Jena HRB 510380

Bankverbindung:
Commerzbank München
IBAN: DEB2 7004 0041 0214 8609 00
BIC: COBADE33XXX

This gives you the measured air volume flow area for a device pair.

Thermal efficiency according to DIN EN 13141-8, the European testing standard. Used to calculate energy efficiency class.

The average heat recovery rate is determined according to DIBt stipulations and must be used in the public-law verification processes according to GEG.

Technical specifications

of the inVENTer system in overview



Overview of the technical specifications



Ventilation systems

iV-Smart+
Compact fan

iV-Smart+ Sylt
Under ground level

iV-Smart+ Top
In the roof

WALL OPENING [mm]	Ø 180	Ø 180	Ø 180
WALL THICKNESS WITH PLASTER [mm]	> 270	> 270	> 270
AIR VOLUME FLOW [m³/h]	8.5 – 29	8.5 – 29	8.5 – 29
EXHAUST AIR VOLUME FLOW [m³/h]	17 – 58	17 – 58	17 – 58
POWER CONSUMPTION [W]	1 – 3	1 – 3	1 – 3
SOUND PRESSURE LEVEL [dB(A)], 2 m	14 – 37	14 – 37	14 – 37
HEAT RECOVERY [%]	87	87	87
VOLUME FLOW RELATED ELECTR. FAN OUTPUT [W/(m³/h)]	0.15	0.15	0.15
WEATHER PROTECTION HOOD [W x H, mm]	279 x 313	Ø 159 x H 880	Ø 265 x H 380
INNER COVER [W x H,mm]	233 x 233	233 x 233	233 x 233
OPERATING TEMPERATURE [°C]	-20 – 50	-20 – 50	-20 – 50
STANDARD SOUND LEVEL DIFFERENCE [dB] ¹⁾	38 – 49	--	41 – 45
ENERGY EFFICIENCY CLASS	A+ / A	A+ / A	A+ / A

¹⁾ Depending on sound insulation accessories, for further information see noise tables page 24 seq.



Ventilation systems

iV14-Zero
Sound-absorbing fan

iV-Light
Compact fan

iV-Compact
Thin walls

WALL OPENING [mm]	Ø 225	Ø 180	Ø 180
WALL THICKNESS WITH PLASTER [mm]	> 255	> 290	> 140
AIR VOLUME FLOW [m³/h]	8.5 – 29	5 – 21	10.5 – 29
EXHAUST AIR VOLUME FLOW [m³/h]	17 – 58	10 – 42	21 – 58
POWER CONSUMPTION [W]	1 – 3	1 – 3	1 – 3
SOUND PRESSURE LEVEL [dB(A)], 2 m	10 – 31	14 – 36	12 – 37
HEAT RECOVERY [%]	87	84	72
VOLUME FLOW RELATED ELECTR. FAN OUTPUT [W/(m³/h)]	0.15	0.2	0.13
WEATHER PROTECTION HOOD [W x H, mm]	279 x 313	Ø 200	203 x 276
INNER COVER [W x H,mm]	233 x 233	220 x 220	233 x 233
OPERATING TEMPERATURE [°C]	-20 – 50	-20 – 50	-20 – 50
STANDARD SOUND LEVEL DIFFERENCE [dB] ¹⁾	48 – 56	34 – 47	32
ENERGY EFFICIENCY CLASS	A+ / A	A+ / A	A

¹⁾ Depending on sound insulation accessories, for further information see noise tables page 24 seq.

Overview of the technical specifications



Ventilation systems

iV-Twin+
Single-room fan

iV-Office
Performance advantage, sound insulation

iV14-MaxAir
Performance advantage

WALL OPENING [mm]	Ø 225	Ø 270	Ø 225
WALL THICKNESS WITH PLASTER [mm]	> 270	> 260	> 280
AIR VOLUME FLOW [m³/h]	5 – 23	10 – 45	10 – 45
EXHAUST AIR VOLUME FLOW [m³/h]	10 – 45	20 – 90	20 – 90
POWER CONSUMPTION [W]	0.5 – 3	1 – 5	1 – 5
SOUND PRESSURE LEVEL [dB(A)], 2 m	14 – 38	12 – 37	20 – 45
HEAT RECOVERY [%]	94	88	88
VOLUME FLOW RELATED ELECTR. FAN OUTPUT [W/(m³/h)]	0.16	0.14	0.14
WEATHER PROTECTION HOOD [W x H, mm]	279 x 313	279 x 313	279 x 313
INNER COVER [W x H,mm]	233 x 233	280 x 280	233 x 233
OPERATING TEMPERATURE [°C]	-20 – 50	-20 – 50	-20 – 50
STANDARD SOUND LEVEL DIFFERENCE [dB] ¹⁾	45 – 56	49 – 55	38 – 45
ENERGY EFFICIENCY CLASS	A+ / A	A+ / A	A+ / A

¹⁾ Depending on sound insulation accessories, for further information see noise tables page 24 seq.



Ventilation systems Corner

	iV-Smart+ Corner	iV14-Zero Corner	iV-Twin+ Corner	iV14-MaxAir Corner
WALL OPENING [mm]	Ø 180	Ø 225	Ø 225	Ø 225
WALL THICKNESS WITH PLASTER [mm]	> 270 / > 70 Insulation	> 270 / > 70 Insulation	> 270 / > 70 Insulation	> 280 / > 70 Insulation
AIR VOLUME FLOW [m³/h]	8.5 – 29	8.5 – 29	5 – 23	10 – 45
EXHAUST AIR VOLUME FLOW [m³/h]	17 – 58	17 – 58	10 – 45	20 – 90
POWER CONSUMPTION [W]	1 – 3	1 – 3	0.5 – 3	1 – 5
SOUND PRESSURE LEVEL [dB(A)], 2 m	14 – 37	10 – 31	14 – 38	20 – 45
HEAT RECOVERY [%]	87	87	94	88
VOLUME FLOW RELATED ELECTR. FAN OUTPUT [W/(m³/h)]	0.15	0.15	0.18	0.14
REVEAL GRILLE [W x H, mm]	70 x 527	70 x 527	70 x 527	70 x 527
INNER COVER [W x H,mm]	233 x 233	233 x 233	233 x 233	233 x 233
OPERATING TEMPERATURE [°C]	-20 – 50	-20 – 50	-20 – 50	-20 – 50
STANDARD SOUND LEVEL DIFFERENCE [dB] ¹⁾	53 – 59	55 – 60	50 – 57	--
ENERGY EFFICIENCY CLASS	A+ / A	A+ / A	A+ / A	A+ / A

¹⁾ Depending on sound insulation accessories, for further information see noise tables page 24 seq.

Overview of the technical specifications

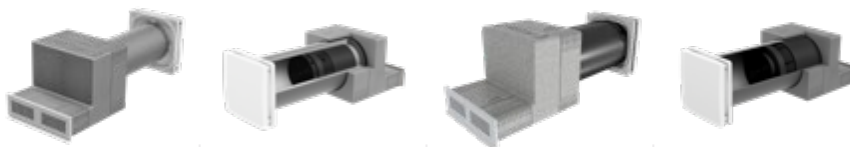

Ventilation systems Nordic	iV-Smart+ Nordic	iV14-Zero Nordic	iV-Twin+ Nordic	iV14-MaxAir Nordic
WALL OPENING [mm]	Ø 180	Ø 225	Ø 225	Ø 225
WALL THICKNESS [mm]	250	250	250	250
INSULATION THICKNESS (INCLUDING GAP AS REQUIRED) [mm]	> 120	> 120	> 120	> 120
TOTAL WALL, CLINKER/THERMAL INSULATION SYSTEM [mm]	> 475/> 370	> 475 / > 370	> 475 / > 370	> 475 / > 370
AIR VOLUME FLOW [m³/h]	8.5 – 29	8.5 – 29	5 – 23	10 – 45
EXHAUST AIR VOLUME FLOW [m³/h]	17 – 58	17 – 58	10 – 45	20 – 90
POWER CONSUMPTION [W]	1 – 3	1 – 3	0.5 – 3	1 – 5
SOUND PRESSURE LEVEL [dB(A)], 2 m	14 – 37	10 – 31	14 – 38	20 – 45
HEAT RECOVERY [%]	87	87	94	88
VOLUME FLOW RELATED ELECTR. FAN OUTPUT [W/(m³/h)]	0.15	0.15	0.16	0.14
OUTER GRILLE [W x H, mm]	280 x 86	280 x 86	280 x 86	280 x 86
INNER COVER [W x H,mm]	233 x 233	233 x 233	233 x 233	233 x 233
OPERATING TEMPERATURE [°C]	-20 – 50	-20 – 50	-20 – 50	-20 – 50
STANDARD SOUND LEVEL DIFFERENCE [dB]	42 – 51	49 – 55	45 – 53	46 – 53
ENERGY EFFICIENCY CLASS	A+ / A	A+ / A	A+ / A	A+ / A

¹⁾ Depending on sound insulation accessories, for further information see noise tables page 24 seq.

Single-room ventilation

X-Flow

AIR VOLUME FLOW [m³/h]	50 – 180
HEAT RECOVERY [%]	87
POWER CONSUMPTION (MAX.) [W]	33.4
SOUND PRESSURE LEVEL [dB(A)], 2 m	12 – 32
INPUT VOLTAGE [V AC, Hz]	230, 50
STANDBY CONSUMPTION [W]	< 1
DIMENSIONS [W X H x D, MM]	520 x 1945 x 202
FILTER	ePM 10-70%
PROTECTION CLASS	I
ENERGY EFFICIENCY CLASS	A



Central residential ventilation

inVENTer PAX

Micro-apartments

AIR VOLUME FLOW [m³/h]	30 – 78 (90 exhaust air)
HEAT RECOVERY [%]	Ø 77 / max. 80
POWER CONSUMPTION [W]	3.5 – 25
PREHEATING RADIATOR [W]	<375
SOUND PRESSURE LEVEL [dB(A)]	19 – 29 (35 exhaust air max.)
OPERATING VOLTAGE [V AC], [Hz]	230, 50
PROTECTION CLASS	IP 24
SUPPLY AIR/EXHAUST AIR FILTER	G4/G4
STANDARD SOUND LEVEL DIFFERENCE [dB]	47 exhaust air space, 77 supply air space
ENERGY EFFICIENCY CLASS	A



Overview of the technical specifications



Controller

sMove s4
For four units

sMove s8
For eight units

MZ-Home
For 16 units in four ventilation zones
MZ-Home control unit Clust-Air module

MAINS VOLTAGE [V AC], [Hz]	230, 50	230, 50	230, 50	--
INPUT VOLTAGE [V DC]	24	24	24	24
FAN VOLTAGE [V DC]	6.7 – 15.3	6.7 – 15.3	--	6 – 16
EXTERNAL INPUT [V DC]	0 – 10	0 – 10	--	0 – 10
POWER CONSUMPTION [W]	max. 11	max. 20	max. 0.5	max. 18
STANDBY [W]	< 1	< 1	1.5 (1 zone) – 2.5 (4 zones)	
PROTECTION CLASS	II	II	II	

inVENTer Connect controller platform



Connect inner cover

For one unit

Connect Twin+/Office/MaxAir inner cover

DIMENSIONS FLUSH-MOUNTED HOUSING W x H x D [mm]	258 x 258 x 66	DIMENSIONS FLUSH-MOUNTED HOUSING W x H x D [mm]	327 x 325 x 61
DIMENSIONS SURFACE-MOUNTED HOUSING W x H x D [mm]	270 x 270 x 66	DIMENSIONS SURFACE-MOUNTED HOUSING W x H x D [mm]	348 x 348 x 61
FLUSH-MOUNTED DESIGN INSTALLATION DEPTH [mm]	+ 38	FLUSH-MOUNTED DESIGN INSTALLATION DEPTH [mm]	+ 43
RADIO FREQUENCY [MHz]	868	RADIO FREQUENCY [MHz]	868
RADIO NETWORK RANGE [m]	Open field: 100 Building: 20	RADIO NETWORK RANGE [m]	Open field: 100 Building: 20
MAINS VOLTAGE [V AC], [Hz]	230, 50	MAINS VOLTAGE [V AC], [Hz]	230, 50
OPERATING VOLTAGE [V DC]	18 – 24	OPERATING VOLTAGE [V DC]	18 – 24
CONTROLLER OUTPUT VOLTAGE [V DC]	6 – 16	CONTROLLER OUTPUT VOLTAGE [V DC]	6 – 16
POWER CONSUMPTION (MAX.) [W]	5	POWER CONSUMPTION (MAX.) [W]	5
INGRESS PROTECTION/PROTECTION CLASS	IP 21/II	INGRESS PROTECTION/PROTECTION CLASS	IPX4 / II

inVENTer Connect controller platform

Controller Easy Connect e16	For 16 units/ sensors in four ventilation zones
CONTROL UNIT DIMENSIONS [W x H x D, mm]	90 x 90 x 15
RADIO FREQUENCY [MHz]	868
RADIO NETWORK RANGE [m]	Open field: 100 Building: 20
MAINS VOLTAGE [V AC], [Hz]	230, 50
OPERATING VOLTAGE [V DC]	5
POWER CONSUMPTION [W]	max. 0.6
INGRESS PROTECTION/ PROTECTION CLASS	IPX2/II

Regler Basic Connect e4/e8	For 4/8 Units + 2 sensors
CONTROL UNIT DIMENSIONS [W x H x T, mm]	90 x 90 x 15
RADIO FREQUENCY [MHz]	868
RADION NETWORK RANGE [m]	Freifeld: 100 Gebäude: 20
MAINS VOLTAGE [V AC], [Hz]	230, 50
OPERATION VOLTAGE [V DC]	5
POWER CONSUMPTION [W]	max. 0,6
INGRESS PROTECTION / PROTECTION CLASS	IPX2 / II

inVENTer exhaust air system:

aV100 wall mounting kit + Avio N 100 | Pulsar (Basic) | Aviant

Wall Mounting Kit aV100

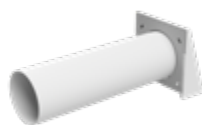

WALL OPENING DIAMETER [mm]	115
WALL THICKNESS [mm]	> 180
WALL MOUNTING SLEEVE DIMENSIONS [Ø, length, mm]	103, 495/745
WEATHER PROTECTION HOOD DIMENSIONS [W x H, mm]	181.5 x 198

Wall mounting kit aV100 Corner



WALL OPENING DIAMETER [mm]	115
WALL THICKNESS/INSULATION [mm]	> 180/> 70
WALL MOUNTING SLEEVE DIMENSIONS [Ø, length, mm]	103, 495/745
SOFFIT GRILLE DIMENSIONS [W x H, mm]	70 x 527
CORNER DUCT DIMENSIONS [W x H, length, mm]	60 x 490, 515

Wall mounting kit aV100 Nordic

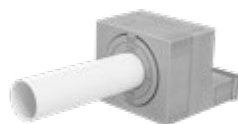





WALL OPENING DIAMETER [mm]	115
WALL THICKNESS/INSULATION [mm]	> 160/> 120
WALL MOUNTING SLEEVE DIMENSIONS [Ø, length, mm]	103, 495/745
OUTER GRILLE DIMENSIONS [W x H, mm]	280 x 86
FACADE END DIMENSIONS [W x H x D, mm]	280 x 240 x 315

Overview of the technical specifications

				
Exhaust fans	Avio N 100 Overrun control	Pulsar Basic/ Pulsar App control	Aviant Sensor Trio: Damp, light, odour	Taris Ventilation according to DIN 18017-3
EXHAUST AIR VOLUME FLOW [m³/h]	75	110	95	60 / 30/60 / 100
POWER CONSUMPTION [W]	6.4	4	2 – 5	19,5
SOUND PRESSURE LEVEL [dB(A)]	28	17 – 20	17 – 20	Distance 2 m. 30 m³/h: UP: 16, AP: 18 60 m³/h: UP 27, AP: 31 100 m³/h: UP: 39, AP: 44
INNER COVER [W x H, mm]	159 x 159	Ø 177	182 x 157	251 x 251
WEATHER PROTECTION HOOD [W x H, mm]	182 – 198 (aV100)	182 – 198 (aV100)	182 – 198 (aV100)	182 x 198 (aV100)
PROTECTION CLASS	II	II	II	II
INGRESS PROTECTION	IPX4	IP44	IP44	IPX5

				
Air inlets	aV100 ALD Basic air inlet	aV100 ALD Plus Metal cover	aV100 ALD Corner Concealed outer cover	aV100 ALD Nordic Subtle facade end
WALL OPENING [mm]	Ø 115	Ø 115	Ø 115	Ø 115
WALL THICKNESS WITH PLASTER [mm]	> 150	> 150	> 150 / > 70 Insulation	> 130 / > 120 Insulation
AIR VOLUME FLOW 4 Pa [m³/h]	7 – 15	7 – 15	7 – 15	7 – 15
AIR VOLUME FLOW 8 Pa [m³/h]	14 – 22	14 – 22	14 – 22	14 – 22
STANDARD SOUND LEVEL DIFFERENCE [dB]	33 – 49	34 – 48	55 – 59	51 – 53
INNER COVER [W x H, mm]	160 x 160	160 x 160	160 x 160	160 x 160
WEATHER PROTECTION HOOD [W x H, mm]	150 x 150	182 x 198	70 x 527	280 x 86

Air inlets				
	aV160 ALD Light Upgradable to iV-Light	aV160 ALD Plus Upgradable to iV-Smart+	aV160 ALD Corner Concealed outer cover	aV160 ALD Nordic Subtle facade end
WALL OPENING [mm]	Ø 180	Ø 180	Ø 180	Ø 180
WALL THICKNESS WITH PLASTER [mm]	> 150	> 150	> 150 / > 70 Insulation	> 130 / > 120 Insulation
AIR VOLUME FLOW 4 Pa [m³/h]	12 – 18	13 – 17	12 – 18	12 – 18
AIR VOLUME FLOW 8 Pa [m³/h]	18 – 24	19 – 23	18 – 24	18 – 24
STANDARD SOUND LEVEL DIFFERENCE [dB]	51 – 52	54 – 55	61	52
INNER COVER [W x H, mm]	220 x 220	220 x 220	220 x 220	220 x 220
WEATHER PROTECTION HOOD [W x H, mm]	Ø 200	279 x 313	70 x 527	280 x 86

Air inlets			
	aV200 ALD Upgradable to iV14-Zero	aV200 ALD Corner Concealed outer cover	aV200 ALD Nordic Subtle facade end
WALL OPENING [mm]	Ø 225	Ø 225	Ø 225
WALL THICKNESS WITH PLASTER [mm]	> 150	> 150 / > 70 Insulation	> 150 / > 120 Insulation
AIR VOLUME FLOW 4 Pa [m³/h]	17	17	17
AIR VOLUME FLOW 8 Pa [m³/h]	26	18 – 24	18 – 24
STANDARD SOUND LEVEL DIFFERENCE [dB]	55	54	56
INNER COVER [W x H, mm]	233 x 233	233 x 233	233 x 233
WEATHER PROTECTION HOOD [W x H, mm]	279 x 313	70 x 527	280 x 86

Values standard sound level difference $D_{n,e,w}$ and assessed sound insulation factor R_w

Ventilation unit	Unit configuration	$D_{n,e,w}$	R_w	A
iV ventilation systems				
iV-Smart+	Standard 1 ¹	38 dB	11.0 dB	0.020 m ²
	Standard 1 + sound insulation insert	43 dB	16.0 dB	
	Standard 1 + SPR	43 dB	16.0 dB	
	Standard 1 + SPR + sound insulation insert	46 dB	19.0 dB	
	Standard 2 ²	41 dB	11.0 dB	0.020 m ²
	Standard 2 + sound insulation insert	47 dB	20.0 dB	
	Standard 2 + SPR	46 dB	19.0 dB	
	Standard 2 + SPR + sound insulation insert	49 dB	22.0 dB	
iV-Smart+ Corner	Standard ³	53 dB	26.0 dB	0.020 m ²
	Standard + sound insulation insert	55 dB	28.0 dB	
	Standard + SPR	57 dB	30.0 dB	
	Standard + SPR + sound insulation insert	59 dB	32.0 dB	
iV-Smart+ Nordic	Standard ⁴	42 dB	15.0 dB	0.020 m ²
	Standard + sound insulation insert	47 dB	20.0 dB	
	Standard + SPR	50 dB	23.0 dB	
	Standard + SPR + sound insulation insert	51 dB	24.0 dB	
iV-Smart+ Top	Standard ⁵	41 dB	14.0 dB	0.020 m ²
	Standard + sound insulation insert	43 dB	16.0 dB	
	Standard + SPR	43 dB	16.0 dB	
	Standard + SPR + sound insulation insert	45 dB	18.0 dB	
iV14-Zero	Standard ⁶	48 dB	23.0 dB	0.031 m ²
	Standard + sound insulation insert	52 dB	27.0 dB	
	Standard + SPR	54 dB	29.0 dB	
	Standard + SPR + sound insulation insert	56 dB	31.0 dB	
iV14-Zero Corner	Standard ⁷	55 dB	30.0 dB	0.031 m ²
	Standard + sound insulation insert	57 dB	32.0 dB	
	Standard + SPR	59 dB	34.0 dB	
	Standard + SPR + sound insulation insert	60 dB	35.0 dB	
iV14-Zero Nordic	Standard ⁸	49 dB	24.0 dB	0.031 m ²
	Standard + sound insulation insert	54 dB	29.0 dB	
	Standard + SPR	52 dB	27.0 dB	
	Standard + SPR + sound insulation insert	55 dB	30.0 dB	
iV-Light	Standard ⁹	34 dB	7.0 dB	0.020 m ²
	Standard + sound insulation insert	41 dB	14.0 dB	
	Standard + SPR	41 dB	14.0 dB	
	Standard + SPR + sound insulation insert	47 dB	20.0 dB	
iV-Compact	Standard ¹⁰	32 dB	5.0 dB	0.020 m ²

Configuration legend, see p. 26

Ventilation unit	Unit configuration	Dn,e,w	Rw	A
iV ventilation systems				
iV-Twin+	Standard ¹¹	45 dB	20.0 dB	0.032 m ²
	Standard + sound insulation insert	52 dB	27.0 dB	
	Standard + SPR	53 dB	28.0 dB	
	Standard + SPR + sound insulation insert	56 dB	31.0 dB	
iV-Twin+ Corner	Standard ^{11a}	50 dB	25.0 dB	0.031 m ²
	Standard + sound insulation insert	53 dB	28.0 dB	
	Standard + SPR	55 dB	30.0 dB	
	Standard + SPR + sound insulation insert	57 dB	32.0 dB	
iV-Twin+ Nordic	Standard ¹²	45 dB	20.0 dB	0.031 m ²
	Standard + sound insulation insert	49 dB	24.0 dB	
	Standard + SPR	51 dB	26.0 dB	
	Standard + SPR + sound insulation insert	53 dB	28.0 dB	
iV-Office	Standard ¹³	49 dB	26.0 dB	0.049 m ²
	Standard + sound insulation insert	53 dB	30.0 dB	
	Standard + SPR	53 dB	30.0 dB	
	Standard + SPR + sound insulation insert	55 dB	32.0 dB	
iV14-MaxAir	Standard ¹⁴	38 dB	13.0 dB	0.031 m ²
	Standard + sound insulation insert	44 dB	19.0 dB	
	Standard + SPR	44 dB	19.0 dB	
	Standard + SPR + sound insulation insert	45 dB	20.0 dB	
iV14-MaxAir Nordic	Standard ¹⁵	46 dB	21.0 dB	0.031 m ²
	Standard + sound insulation insert	49 dB	24.0 dB	
	Standard + SPR	51 dB	26.0 dB	
	Standard + SPR + sound insulation insert	53 dB	28.0 dB	
Central residential ventilation				
inVENTer PAX	Main module (exhaust air space)	47 dB	28.0 dB	0.121 m ²
	Main module + silencer D100 + spiral duct D100 + poppet valve (supply air space)	77 dB	46.0 dB	0.008 m ²

Configuration legend, see p. 26

Ventilation unit	Unit configuration	Dn,e,w	Rw	A
aV exhaust air systems				
aV100 Wall mounting kit	Standard ¹⁶	29 dB	-2.0 dB	0.008 m ²
aV100 Wall Mounting Kit Corner	Standard ¹⁷	53 dB	22.0 dB	
aV100 Wall Mounting Kit Nordic	Standard ¹⁸	38 dB	7.0 dB	
Air inlets ALD				
aV100 ALD	Standard ¹⁹	33 dB	2.0 dB	0.008 m ²
	Standard + sound insulation insert	49 dB	18.0	
aV100 ALD Plus	Standard ²⁰	34 dB	3.0 dB	0.008 m ²
	Standard + sound insulation insert	48 dB	17.0 dB	
aV100 ALD Corner	Standard ²¹	55 dB	24.0 dB	0.008 m ²
	Standard + sound insulation insert	59 dB	28.0 dB	
aV100 ALD Nordic	Standard ²²	51 dB	20.0 dB	0.008 m ²
	Standard + sound insulation insert	53 dB	22.0 dB	
aV160 ALD Light	Standard ²³	51 dB	24.0 dB	0.020 m ²
aV160 ALD Plus	Standard ²⁴	54 dB	27.0 dB	0.020 m ²
aV160 ALD Corner	Standard ²⁵	57 dB	30.0 dB	0.020 m ²
	Standard + sound insulation insert ³⁰	61 dB	34.0 dB	0.020 m ²
aV160 ALD Nordic	Standard ²⁶	52 dB	25.0 dB	0.020 m ²
aV200 ALD	Standard ²⁷	55 dB	30.0 dB	0.031 m ²
aV200 ALD Corner	Standard ²⁸	54 dB	29.0 dB	0.031 m ²
aV200 ALD Nordic	Standard ²⁹	56 dB	31.0 dB	0.031 m ²

Configuration legend

- 1 iV-Smart+ in configuration with Flair SDE/IB Connect inner cover and Smart weather protection hood
 - 2 iV-Smart+ in configuration with Flair SDE/IB Connect inner cover and Flex weather protection hood
 - 3 iV-Smart+ Corner in configuration with Flair SDE/IB Connect inner cover and Corner flat duct with soffit grille
 - 4 iV-Smart+ Nordic in configuration with Flair SDE/IB Connect inner cover and Nordic end with outer grille
 - 5 iV-Smart+ in configuration with Flair SDE/IB Connect inner cover and Top weather protection hood
 - 6 iV14-Zero in configuration with Flair Zero/IB Connect inner cover and Flex Zero weather protection hood
 - 7 iV14-Zero Corner in configuration with Flair Zero/IB Connect inner cover and Corner flat duct with soffit grille
 - 8 iV14-Zero Nordic in configuration with Flair Zero/IB Connect inner cover and Nordic end with outer grille
 - 9 iV-Light in configuration with Light/IB Connect inner cover and Light weather protection grille
 - 10 iV-Compact in configuration with Flair SDE/IB Connect inner cover and Compact weather protection hood
 - 11 iV-Twin+ in configuration with Flair Twin+ inner cover and Flex Twin+ weather protection hood
 - 11a iV-Twin+ Corner in configuration with Flair Twin+ inner cover and Corner flat duct with soffit grille
 - 12 iV-Twin+ Nordic in configuration with Flair Twin+ inner cover and Nordic end with outer grille
 - 13 iV-Office in configuration with Flair XL inner cover and Flex Office weather protection hood
 - 14 iV14-MaxAir in configuration with Flair SDE inner cover and Flex weather protection hood
 - 15 iV14-MaxAir Nordic in configuration with Flair SDE inner cover and Nordic end with outer grille
-
- 16 aV100 wall mounting kit in configuration with exhaust air unit and aV100 weather protection hood
 - 17 aV100 wall mounting kit in configuration with Corner exhaust air unit and flat duct with soffit grille
 - 18 aV100 wall mounting kit in configuration with exhaust air unit and Nordic end with outer grille
 - 19 aV100 ALD in configuration with ALD insert including aV100 inner cover and weather protection grille
 - 20 aV100 ALD Plus in configuration with ALD insert including aV100 inner cover and weather protection hood
 - 21 aV100 ALD Corner in configuration with ALD insert including Corner inner cover and flat duct with soffit grille
 - 22 aV100 ALD Nordic in configuration with ALD insert including inner cover and Nordic end with outer grille
 - 23 aV160 ALD Light in configuration with ALD insert including Light inner cover and weather protection grille
 - 24 aV160 ALD Plus in configuration with ALD insert including Light inner cover and Flex weather protection hood
 - 25/30 aV160 ALD Corner in configuration with ALD insert including Light inner cover and Corner flat duct with soffit grille
 - 26 aV160 ALD Nordic in configuration with ALD insert including Light inner cover and Nordic end with outer grille
 - 27 aV200 ALD in configuration with Flair Zero inner cover, ALD insert, and Flex weather protection hood
 - 28 aV200 ALD Corner in configuration with Flair Zero inner cover, ALD insert, and Corner flat duct with soffit grille
 - 29 aV200 ALD Nordic in configuration with Flair Zero inner cover, ALD insert, and Nordic end with outer grille

Assembly and installation tools

for ventilation units



Simplex wall mounting system



Wall mounting system for the iv-Smart+, iv14-Zero, iv-Twin+, iv-Light, iv-Compact, iv14-MaxAir, iv-Office, and aV100 / aV160 ALD decentralised ventilation systems and their variants. Used in new buildings for quick installation. Consisting of installation block and pre-installed wall installation sleeve as a unit. Integration into the brickwork in the shell. Installed wall installation sleeve replaces core hole drilling and installation of the wall installation sleeve. Made-to-measure ex works according to customer-specific wall construction.

Features

- Individually adapted wall mounting block with optimised thermal insulation
- Wall mounting sleeve installed in a sound-insulated manner in the installation block with integrated slope to condensate drain
- RAL-compliant installation, structure open to diffusion on the outside and tight to diffusion on the inside
- Installation block height corresponds to the standard brick dimension of 249 mm (iv-Office/WEH R-D250: 330x330 mm)
- Recesses on outer sides for extra secure hold in masonry (except for iv-Office/WEH R-D250)
- Fire behaviour: flame retardant (DIN 4102-B1)

Technical specifications

DIMENSIONS OF MOUNTING BLOCK [WxH, mm]	
Wall mounting sleeve 103,160, 200 mm	260 x 249
Wall mounting sleeve 250 mm	330 x 330
DIAMETER OF WALL MOUNTING SLEEVE [mm]	
aV100 / aV100 ALD	103
iv-Smart+ / iv-Light / iv-Compact aV160 ALD	160
iv14-Zero / iv-Twin+ / iv14-MaxAir / aV200 ALD	200
iv-Office	250
MATERIAL	Neopor®
FIRE BEHAVIOUR DIN 4102	B1: flame retardant
FIRE BEHAVIOUR DIN EN-ISO	1
MINIMUM DISTANCES STARTING FROM CENTRE AXIS:	
circumferential to other components	250 mm
to other air openings	1.2 m
frontal in the interior	300 mm

Simplex wall mounting system installation diagram

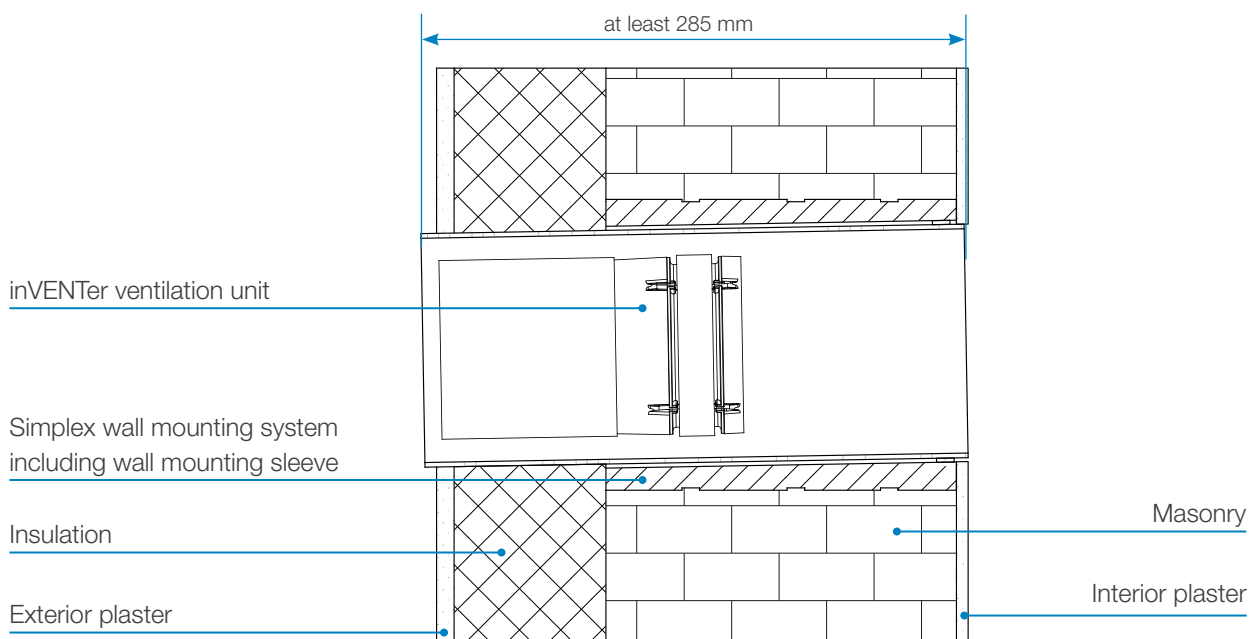

Simplex Connect wall mounting system

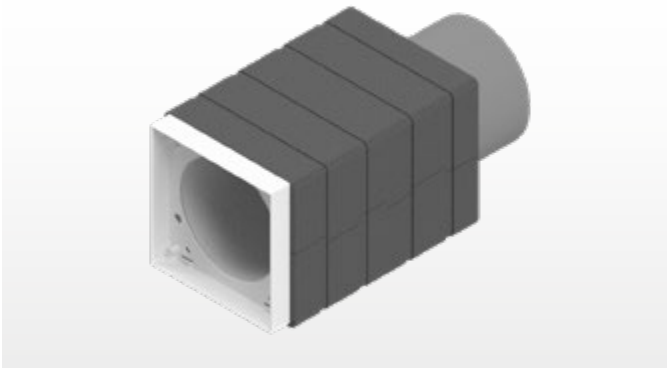

Wall mounting system for the iV-Smart+ and iV14-Zero decentralised ventilation systems in conjunction with the inVENTer Connect controller platform. For new buildings with flush-mounted inner cover for quick installation. Consisting of mounting block, housing inner cover Connect and pre-installed wall mounting sleeve as a unit. Integration into the brickwork in the shell. Installed wall mounting sleeve replaces core hole drilling and mounting of wall mounting sleeve and housing. Made-to-measure ex works according to customer-specific wall construction.

Features

- Individually adapted wall mounting block with optimised thermal insulation
- Wall mounting sleeve installed in a sound-insulated manner in the installation block with integrated slope to condensate drain
- Permanently installed housing for Connect inner cover
- RAL-compliant installation, structure open to diffusion on the outside and tight to diffusion on the inside
- The height of the installation block corresponds to the standard brick dimension of 249 mm
- Recesses on outer sides for extra secure hold in masonry
- Fire behaviour: flame retardant (DIN 4102-B1)

Technical specifications

DIMENSIONS OF MOUNTING BLOCK [WxH, mm]	260 x 249
DIAMETER OF WALL MOUNTING SLEEVE [mm]	iV-SMART+: 160 iV14-Zero: 200
MATERIAL	Neopor®, PPs
FIRE BEHAVIOUR DIN 4102	B1: flame retardant
FIRE BEHAVIOUR DIN EN-ISO	1
MINIMUM DISTANCES STARTING FROM CENTRE AXIS:	
circumferential to other components	250 mm
to other air openings	1.2 m
frontal in the interior	300 mm

Simplex Connect wall mounting system installation diagram

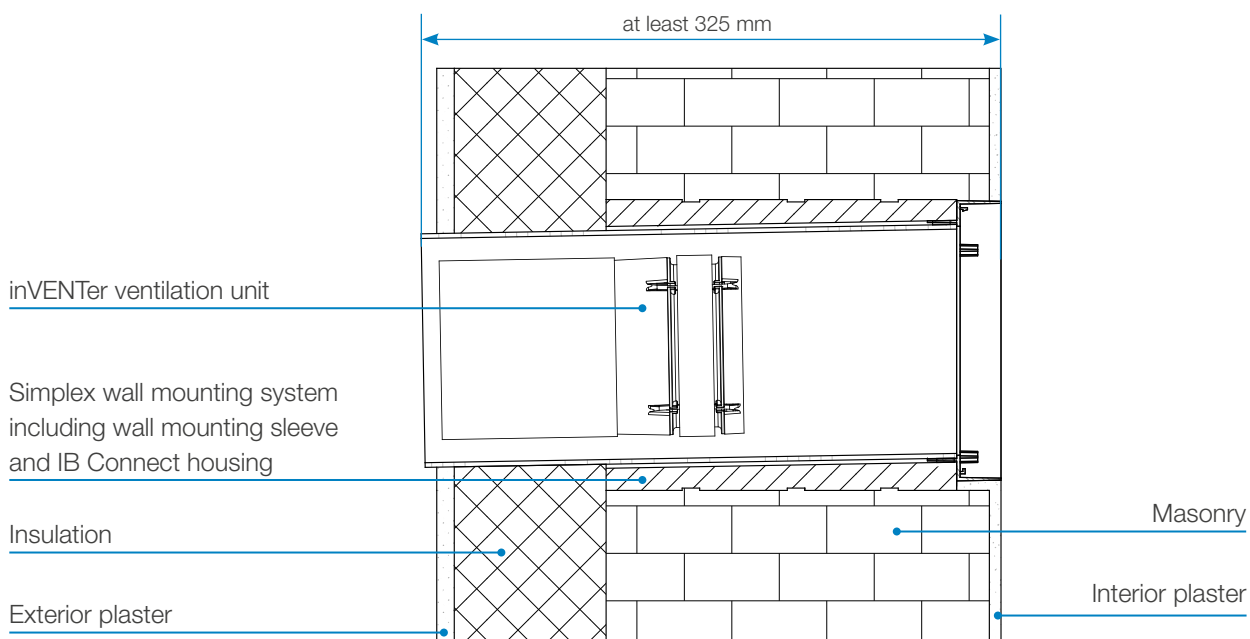

Nordplex wall mounting system

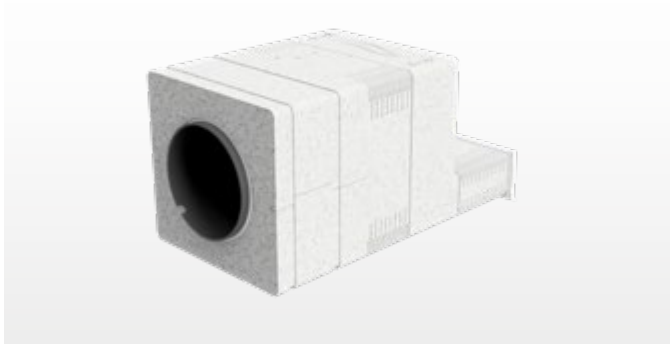

Wall mounting system for the iV-Smart+, iV14-Zero, iV-Twin+, iV-Light, iV-Compact, iV14-MaxAir, and aV100/aV160 ALD decentralised ventilation systems and their variants. Used in new buildings for quick installation.

Consisting of installation block and pre-installed wall installation sleeve as a unit. Integration into the brickwork in the shell. Installed wall installation sleeve replaces core hole drilling and installation of the wall installation sleeve.

Made-to-measure ex works according to customer-specific wall construction.

Features

- Individually adapted wall mounting block with optimised thermal insulation
- Wall mounting sleeve installed in a sound-insulated manner in the installation block with integrated slope to condensate drain
- RAL-compliant installation, structure open to diffusion on the outside and tight to diffusion on the inside
- The height of the installation block corresponds to the standard brick dimension of 249 mm
- Recesses on outer sides for extra secure hold in masonry
- Fire behaviour: flame retardant (DIN 4102-B1)

Technical specifications

DIMENSIONS OF MOUNTING BLOCK [WxH, mm]	260 x 249
DIAMETER OF WALL MOUNTING SLEEVE [mm]	
aV100 / aV100 ALD	103
iV-Smart+ / iV-Light / iV-Compact aV160 ALD	160
iV14-Zero / iV-Twin+ / iV14-MaxAir / aV200 ALD	200
FIRE BEHAVIOUR DIN 4102	B1: flame retardant
FIRE BEHAVIOUR DIN EN-ISO	1
MINIMUM DISTANCES STARTING FROM CENTRE AXIS:	
circumferential to other components	250 mm
to other air openings	1.2 m
frontal in the interior	300 mm

Installation diagram for Nordplex wall mounting system with external insulation and interior and exterior plaster

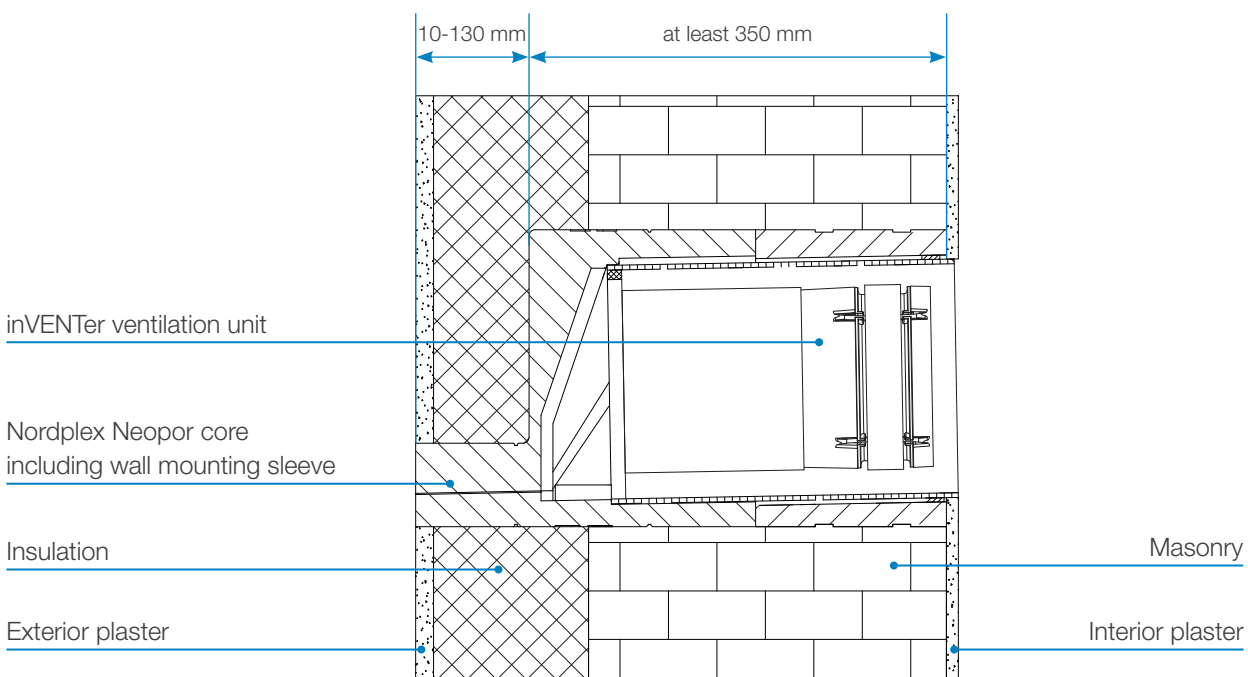

Nordplex Connect wall mounting system



Wall mounting system for the iV-Smart+ and iV14-Zero decentralised ventilation systems in conjunction with the inVENTer Connect controller platform. For new buildings with flush-mounted inner cover for quick installation.

Consisting of mounting block, housing inner cover Connect and pre-installed wall mounting sleeve as a unit. Integration into the brickwork in the shell. Installed wall mounting sleeve replaces core hole drilling and mounting of wall mounting sleeve and housing. Made-to-measure ex works according to customer-specific wall construction.

Features

- Individually adapted wall mounting block with optimised thermal insulation
- Wall mounting sleeve installed in a sound-insulated manner in the installation block with integrated slope to condensate drain
- Permanently installed housing for Connect inner cover
- RAL-compliant installation, structure open to diffusion on the outside and tight to diffusion on the inside
- The height of the installation block corresponds to the standard brick dimension of 249 mm
- Recesses on outer sides for extra secure hold in masonry
- Fire behaviour: flame retardant (DIN 4102-B1)

Technical specifications

DIMENSIONS OF MOUNTING BLOCK [WxH, mm]	260 x 249
DIAMETER OF WALL MOUNTING SLEEVE [mm]	iV-Smart+ / iV-Compact: 160 iV14-Zero: 200
FIRE BEHAVIOUR DIN 4102	B1: flame retardant
FIRE BEHAVIOUR DIN EN-ISO	1
MINIMUM DISTANCES STARTING FROM CENTRE AXIS:	
circumferential to other components	250 mm
to other air openings	1.2 m
frontal in the interior	300 mm

Installation diagram for Nordplex Connect wall mounting system with external insulation and interior and exterior plaster

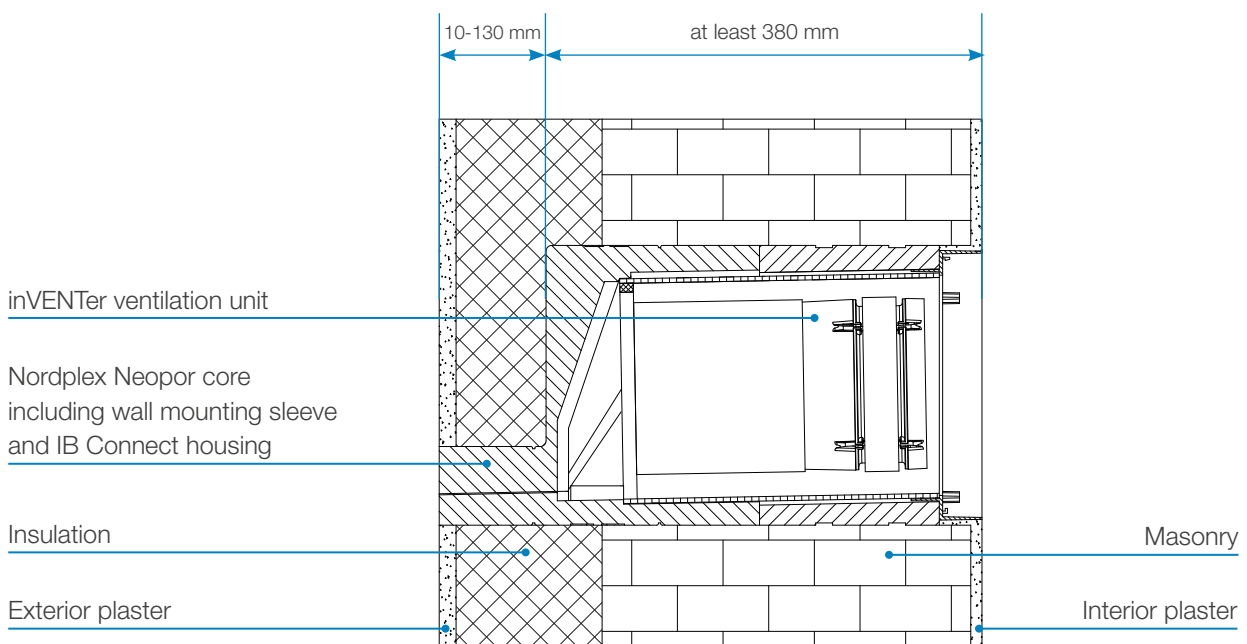

Wall mounting block WEB

Wall mounting block WEB D120



Installation kit for the exhaust air system aV100. Replaces core drill hole for the aV100 wall installation set / aV100 ALD For new buildings. For new buildings. Integration into the brickwork in the shell.

Features

- Wall mounting block with optimized specific thermal conductivity
- Recesses on outer sides for extra secure hold in masonry
- Trunnion system for combining individual blocks for required wall thickness
- Depth per wall mounting block 120 mm, can be shortened individually
- Fire behaviour: flame retardant (DIN4102-B1)
- Material Neopor®
- Dimensions [W x H x D, mm] 210 x 249 x 120
- Internal opening [Ø, mm]: 120

Wall mounting block WEB D180



Installation tool for the iV-Smart+, iV-Light, iV-Compact, and aV160 ALD decentralised ventilation systems. Replaces core hole drilling for Ø 160 mm wall mounting sleeve. For new buildings. Integration into the brickwork in the shell.

Features

- Wall mounting block with optimized specific thermal conductivity
- Recesses on outer sides for extra secure hold in masonry
- Trunnion system for combining individual blocks for required wall thickness
- Depth per wall mounting block 120 mm, can be shortened individually
- Fire behaviour: flame retardant (DIN4102-B1)
- Material Neopor®
- Dimensions [W x H x D, mm] 210 x 249 x 120
- Internal opening [Ø, mm]: 180

Wall mounting block WEB D230

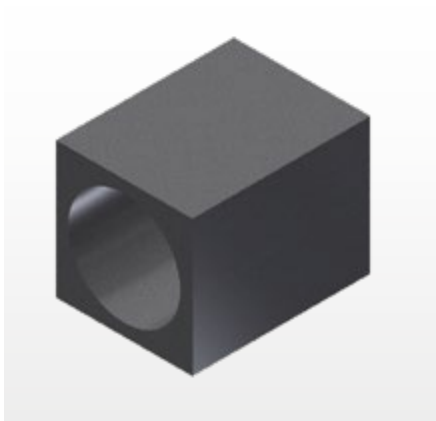

Installation tool for the iV14-Zero, iV14-Zero Corner, iV-Twin+, and iV14-MaxAir decentralised ventilation systems. Replaces core hole drilling for Ø 200 mm wall mounting sleeve. For new buildings. Integration into the brickwork in the shell.

Features

- Wall mounting block with optimized specific thermal conductivity
- Combination of individual blocks for required wall thickness
- Depth per wall mounting block 365 mm, can be shortened individually
- Fire behaviour: flame retardant (DIN4102-B1)
- Material Neopor®
- Dimensions [W x H x D, mm] 280 x 280 x 365
- Internal opening [Ø, mm]: 230

Woodplex wall mounting system



Wall mounting system consisting of wood materials and insulation for decentralised iV ventilation systems and aV exhaust air systems.

Replaces core hole drilling for 103 mm / Ø 160 mm / Ø 200 mm wall mounting sleeve. For integration into wood frame / stand construction.

Features

- Individually adjusted wall mounting block consisting of wood frames and two-sided panelling with frame panel and base plate (OSB boards)
- Completely insulated
- Insulation material for selection: glass wool/mineral wool/ wood fibre insulation
- Permanently integrated opening for installing the wall mounting sleeve

Technical specifications

PREFABRICATED WALL THICKNESS [mm]	≤ 215
FRAME WITH FRAME PANEL (W x H x D) [mm]	350 x 350 x 120 – 200
Base plate (W x H x D) [mm]	615 x 515 x 12 – 18
Internal opening Ø [mm]	125 / 180 / 225 (for core hole drilling for Ø 103 mm / Ø 160 mm / Ø 200 mm wall mounting sleeve)

Woodplex wall mounting system installation position

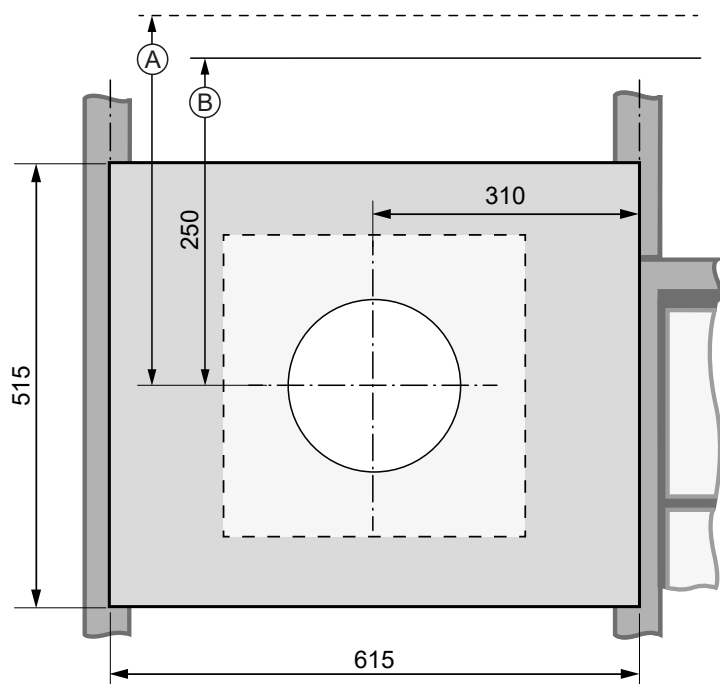

(A) Distance to components on the outer wall

(B) Distance to components on the inner wall

Ventilation systems

with heat recovery



inVENTer iV-Smart+



iV-Smart+ complete system, interior view

Decentralised ventilation system with heat recovery.
Five-year manufacturer's warranty. Compact unit for new construction and renovation for easy integration in exterior walls.

External control via controller.

Quick installation with Simplex: Installation block with pre-installed wall installation sleeve, integrated slope.

Minimal operating costs thanks to low power consumption of 3 W and the possibility of user maintenance.

Components

- Insert with ceramic honeycomb heat accumulator
- inVENTron®: Xenion® reversing fan with temperature monitor and wind pressure stabilizer, embedded in double air fin for flow rectification. Fan meets S3 classification according to DIN EN 13141-8.
- Inner cover with G4 filter (ISO Coarse 60%), wall mounting sleeve, driving-rain-proof weather protection hood

Controller

- MZ-Home, sMove s4/s8, controller system inVENTer Connect

Accessories (optional)

- Pollen filter, activated carbon filter, hygiene filter
- D180 or Simplex R-D160 wall mounting block
- Sound and wind protection accessories

External cover iV-Smart+
Flex Weather Protection Hood

White: RAL9016
Grey: RAL9006
Anthracite: RAL7016

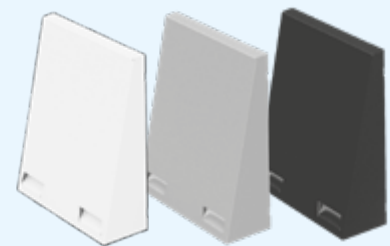

Inner cover iV-Smart+
Inner cover Flair (RAL9010)



Technical specifications

HEAT RECOVERY [%]	87
AIR VOLUME FLOW PER UNIT [m³/h]	8.5 – 29
EXHAUST AIR VOLUME FLOW PER UNIT [m³/h]	17 – 58
SOUND PRESSURE LEVEL [dB(A)], distance 2 m	14 – 37
STANDARD SOUND LEVEL DIFFERENCE $D_{n,e,w}$ [dB]	38 – 49
FLAIR INNER COVER DIMENSIONS [W x H, mm]	233 x 233
WEATHER PROTECTION HOOD DIMENSIONS [W x H, mm]	279 x 313

MINIMUM WALL THICKNESS [mm]	270
WALL OPENING DIAMETER [mm]	180
WALL MOUNTING SLEEVE DIAMETER [mm]	160
POWER CONSUMPTION [W]	1 – 3
VOLUME-FLOW-RELATED POWER CONSUMPTION [W/(m³/h)]	0.15
INGRESS PROTECTION	IP20
INPUT VOLTAGE [V DC]	6 – 16
ENERGY EFFICIENCY CLASS	A+ / A

Installation scheme iV-Smart+

► The installation scheme with IB Connect UP/AP can be found in the „inVENTer Connect controller platform“ subsection.

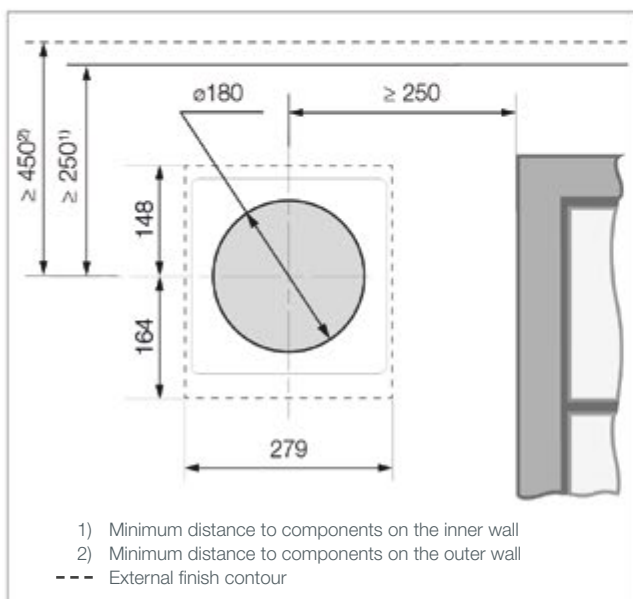
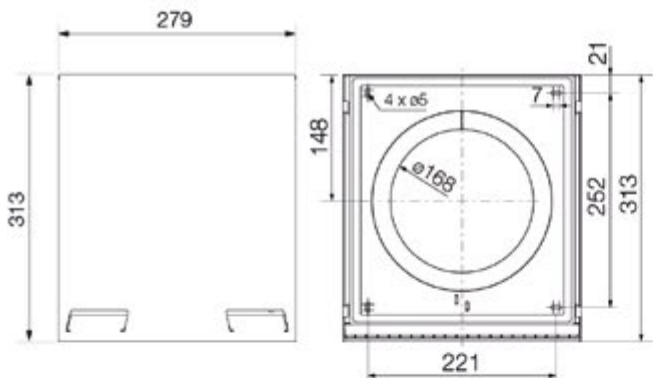
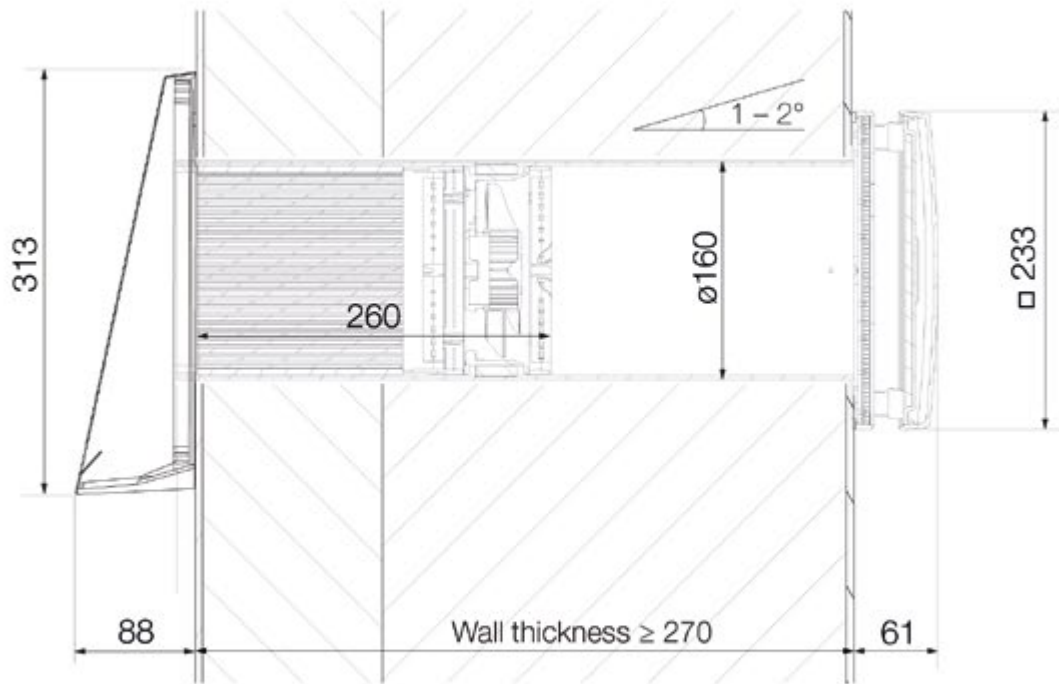

Remarks

To ensure that the system can be installed, observe the minimum clearances shown in the adjacent illustration.
 Minimum wall thickness: 270 mm.

Minimum distances from centre axis core bore

- to components on the inner wall/reveal: 250 mm circumferential
- to components on the outer wall 250 mm circumferential 250 mm lateral/bottom, 450 mm top; mind lintels, reveal edges, insulation thickness, and any shutters.
- between two ventilation units in the same room: 1.2 m.
- to other ventilation systems in the external area: 1.2 m.
- Mount in the room air volume flow at about 1.80 m above the upper edge of the finished floor.
- Recommendation: For a better appearance on the facade, attach the upper edge of the weather protection hood at the height of the lower edge of the lintel.

All assembly and operating instructions as well as further information can be found at www.inventer.de.



DXF / DWG / STP

inVENTer iV-Smart+ Corner

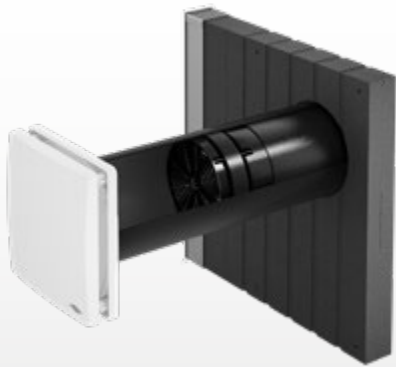

iV-Smart+ complete system, interior view

Decentralised ventilation system with heat recovery. Five-year manufacturer's warranty. Compact unit for new construction and renovation as reveal variant with concealed external finish for easy integration into external walls with external wall insulation.

External control via controller.

Minimal operating costs thanks to low power consumption of 3 W and the possibility of user maintenance.

Quick installation with Simplex: Installation block with pre-installed wall installation sleeve, integrated slope.

Components

- Insert with ceramic honeycomb heat accumulator
- inVENTron®: Xenion® reversing fan with temperature monitor and wind pressure stabilizer, embedded in double air fin for flow rectification. Fan meets S3 classification according to DIN EN 13141-8.
- Inner cover with G4 filter (ISO Coarse 60%), wall mounting sleeve
- Corner flat duct with integrated slope (including reveal grille)

Controller

- MZ-Home, sMove s4/s8, controller system inVENTer Connect

Accessories (optional)

- Pollen filter, activated carbon filter, hygiene filter
- D160 substructure board
- D180 or Simplex R-D160 wall mounting block
- Sound and wind protection accessories

Technical specifications

HEAT RECOVERY [%]	87
AIR VOLUME FLOW PER UNIT [m³/h]	8.5 – 29
EXHAUST AIR VOLUME FLOW PER UNIT [m³/h]	17 – 58
SOUND PRESSURE LEVEL [dB(A)], distance 2 m	14 – 37
STANDARD SOUND LEVEL DIFFERENCE $D_{n,e,w}$ [dB]	53 – 59
FLAIR INNER COVER DIMENSIONS [W x H, mm]	233 x 233
SOFFIT GRILLE DIMENSIONS [W x H, mm]	70 x 512

MINIMUM WALL THICKNESS/INSULATION [mm]	> 270 / > 120
MINIMUM WALL THICKNESS [mm]	340
WALL OPENING DIAMETER [mm]	180
WALL MOUNTING SLEEVE DIAMETER [mm]	160
POWER CONSUMPTION [W]	1 – 3
VOLUME-FLOW-RELATED POWER CONSUMPTION [W/(m³/h)]	0.15
INGRESS PROTECTION	IP20
INPUT VOLTAGE [V DC]	6 – 16
ENERGY EFFICIENCY CLASS	A+ / A



Installation scheme iV-Smart+ Corner, top view

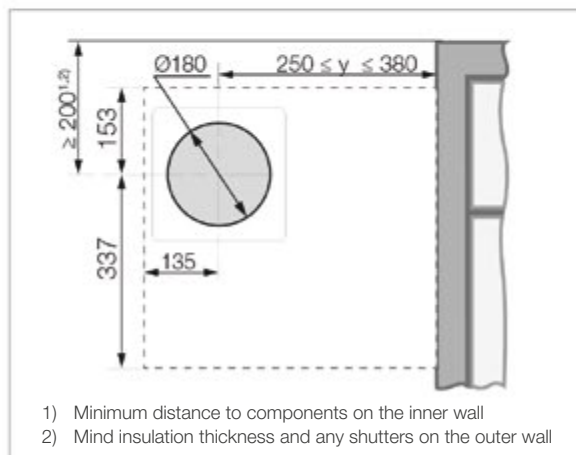
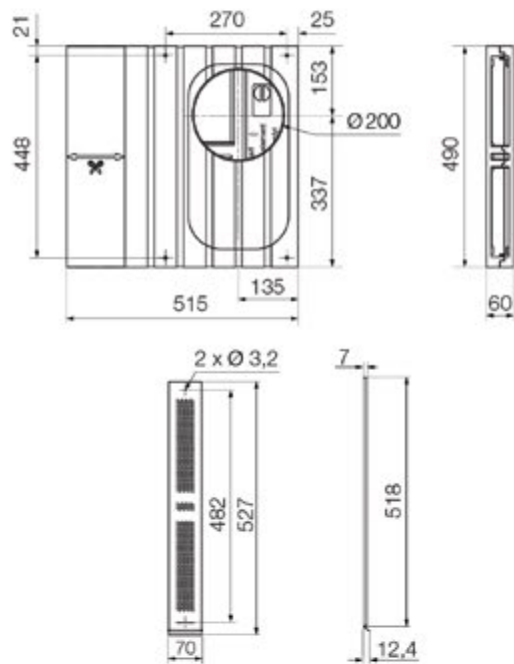
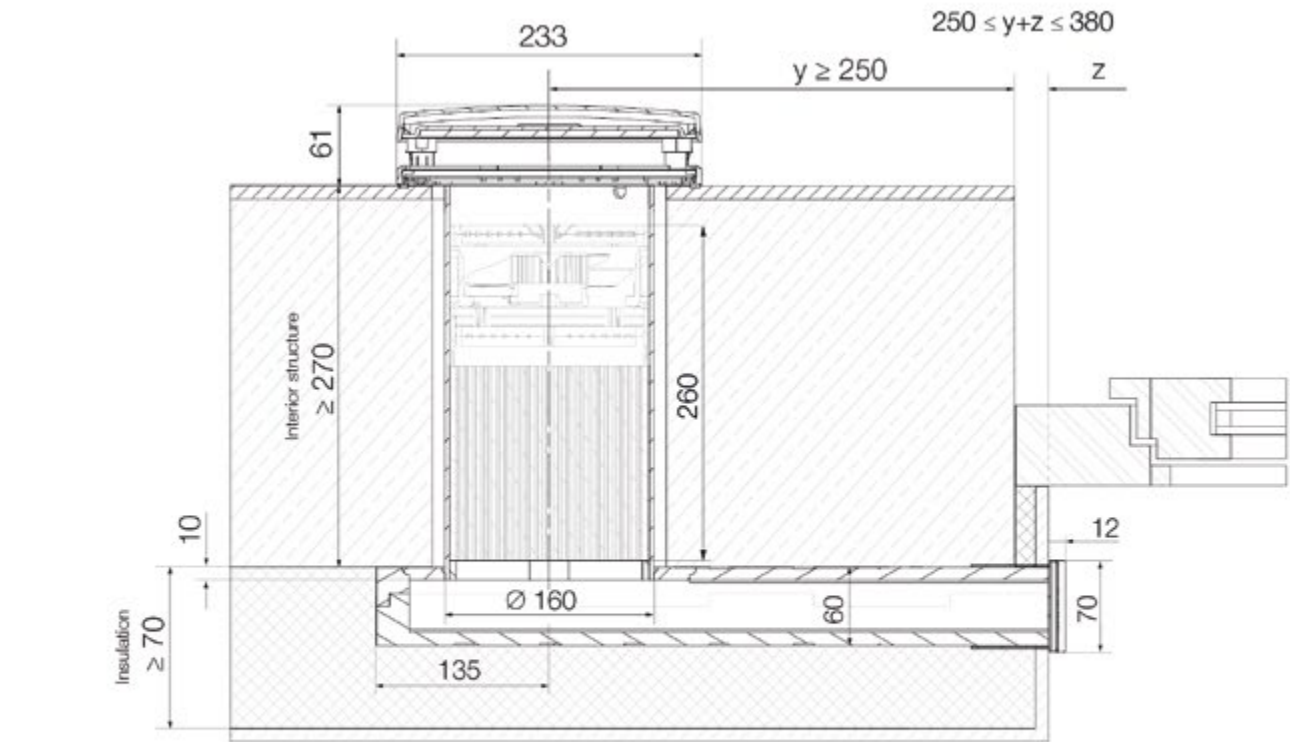

Remarks

When installing, observe the minimum distances in order to ensure that the system can be installed and functions properly. Minimum internal structure: When installing, observe the minimum distances in order to ensure that the system can be installed and functions properly. The flat duct can be underlaid with insulating material (such as the inVENTer UBP Corner substructure board).

Minimum distances from centre axis core bore

- Insulation thickness on flat duct: > 10 mm
- to reveal (outside): 250 – 380 mm
- to components on the outer wall/intel: 200 mm circumferential, mind insulation thickness and any shutters
- between two ventilation units in the same room: 1.2 m
- to other ventilation systems in the external area: 1.2 m

• Installation length of the flat duct:

$$L = (y + z) + 135, \text{ whereby } 250 \leq (y+z) \leq 380$$

All assembly and operating instructions as well as further information can be found at www.inventer.de.



DXF / DWG / STP

inVENTer iV-Smart+ Nordic



iV-Smart+ Nordic complete system, interior view

Decentralised ventilation system with heat recovery. Five-year manufacturer's warranty. Compact unit for new construction and renovation with external finish flush with the facade for easy integration into clinker facades or exterior walls with insulation.

External control via controller.

Minimal operating costs thanks to low power consumption of 3 W and the possibility of user maintenance.

Quick installation with Simplex: Installation block with pre-installed wall installation sleeve, integrated slope.

Components

- Insert with ceramic honeycomb heat accumulator
- inVENTron®: Xenion® reversing fan with temperature monitor and wind pressure stabilizer, embedded in double air fin for flow rectification. Fan meets S3 classification according to DIN EN 13141-8.
- Inner cover with G4 filter (ISO Coarse 60%), wall mounting sleeve
- Nordic facade end (including outer grille)

Controller

- MZ-Home, sMove s4/s8, controller system inVENTer Connect

Accessories (optional)

- Pollen filter, activated carbon filter, hygiene filter
- D180 or Simplex R-D160 wall mounting block
- Soundproofing accessories

External cover iV-Smart+ Nordic

Outer grille

White: RAL9016

Grey: RAL9006

Anthracite: RAL7016

Copper brown: RAL8004

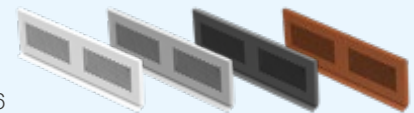

Internal cover

iV-Smart+ Nordic:

Flair inner cover (RAL9010)



Technical specifications

HEAT RECOVERY [%]	87
AIR VOLUME FLOW PER UNIT [m³/h]	8.5 – 29
EXHAUST AIR VOLUME FLOW PER UNIT [m³/h]	17 – 58
SOUND PRESSURE LEVEL [dB(A)], distance 2 m	14 – 37
STANDARD SOUND LEVEL DIFFERENCE $D_{n,e,w}$ [dB]	42 – 51
FLAIR INNER COVER DIMENSIONS [W x H, mm]	233 x 233
OUTER GRILLE DIMENSIONS [W x H, mm]	280 x 86
WALL OPENING DIAMETER [mm]	180
WALL MOUNTING SLEEVE DIAMETER [mm]	160

MINIMUM WALL THICKNESS [mm]	250
+ INSULATION (INCL. GAP AS REQUIRED) [mm]	> 120
+ ANY CLINKER [mm]	115
TOTAL WALL, CLINKER / THERMAL INSULATION SYSTEM [mm]	> 475 / > 370
POWER CONSUMPTION [W]	1 – 3
VOLUME-FLOW-RELATED POWER CONSUMPTION [W/(m³/h)]	0.15
INGRESS PROTECTION	IP20
INPUT VOLTAGE [V DC]	6 – 16
ENERGY EFFICIENCY CLASS	A+ / A

Installation scheme for double-shell masonry with facing bricks (clinker)

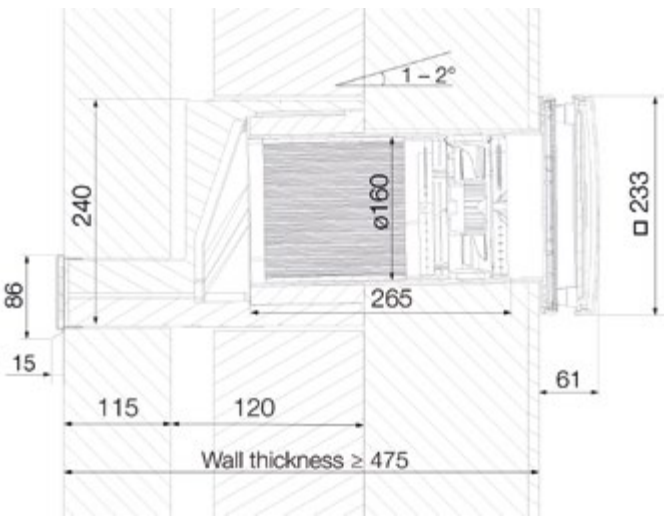

Installation scheme for single-shell masonry with thermal insulation system

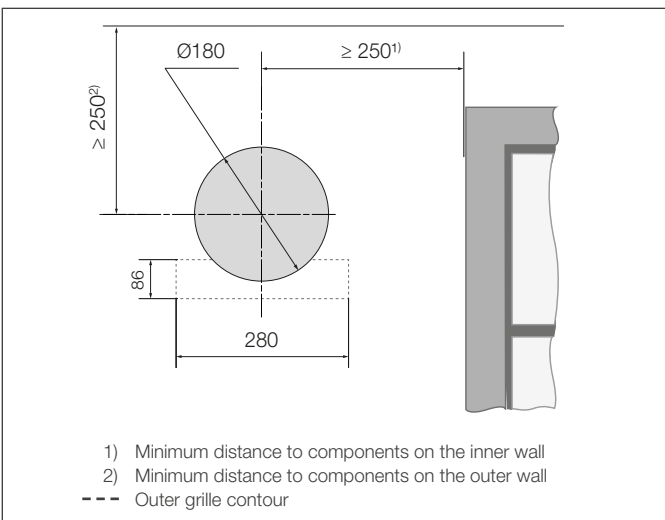
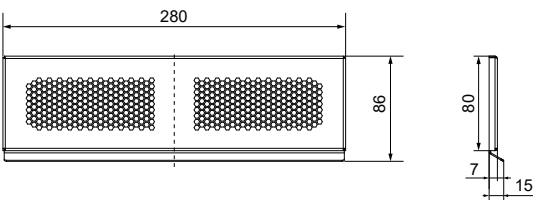
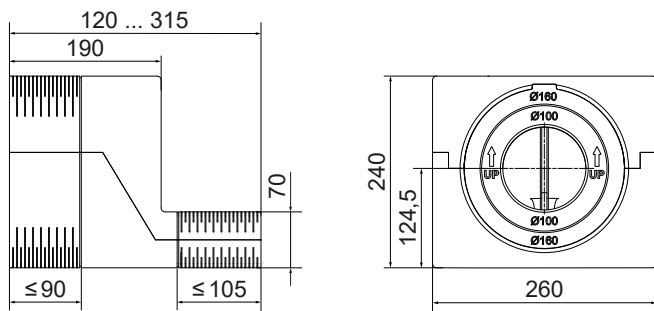
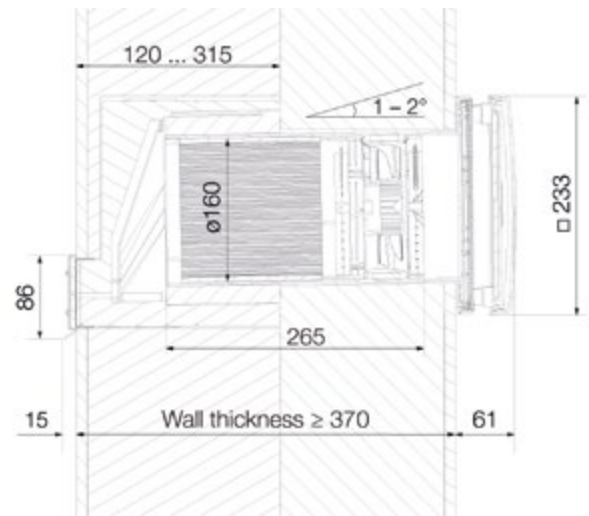

Remarks

When installing, observe the minimum distances in order to ensure that the system can be installed and functions properly.

Minimum overall wall thickness for clinker: 475 mm

Minimum overall wall thickness for thermal insulation system: 370 mm

Minimum insulation thickness including gap as required: 120 mm

Minimum distances from centre axis core bore

- to components on the inner wall/reveal: 250 mm circumferential
- to components on the outer wall 250 mm circumferential, mind lintels, reveal edges, insulation thickness, and any shutters
- between two ventilation units in the same room: 1.2 m
- to other ventilation systems in the external area: 1.2 m
- Mount in the room air volume flow at about 1.80 m above the upper edge of the finished floor

All assembly and operating instructions and further information can be found at www.inventer.de.



DXF / DWG / STP

inVENTer iV-Smart+ Sylt



iV-Smart+ Sylt complete system, interior view

Decentralised ventilation system with heat recovery.
Five-year manufacturer's warranty. For use in rooms below the earth's surface, basement, low ground floor.
Complete system for easy integration into the exterior wall.
External control via controller.

Minimal operating costs thanks to low power consumption of 3 W and the possibility of user maintenance.

Material for fitting to the facade or building base included.

Components

- Insert with ceramic honeycomb heat accumulator
- inVENTron®: Xenion® reversing fan with temperature monitor and wind pressure stabilizer, embedded in double air fin for flow rectification. Fan meets S3 classification according to DIN EN 13141-8.
- Inner cover with G4 filter (ISO Coarse 60%), wall mounting sleeve, riser pipe with condensate drain, hood pipe with hood cover

Controller

- MZ-Home, sMove s4/s8, controller system inVENTer Connect

Accessories (optional)

- Pollen filter, activated carbon filter, hygiene filter
- D180 wall mounting block

External cover iV-Smart+ Sylt
Weather protection hood Sylt

White: RAL9016
Beige: RAL1001
Grey: RAL9006
Dark grey: RAL7015



Internal cover
iV-Smart+ Sylt:
Inner cover Flair (RAL9010)



Technical specifications

HEAT RECOVERY [%]	87
AIR VOLUME FLOW PER UNIT [m³/h]	8.5 – 29
EXHAUST AIR VOLUME FLOW PER UNIT [m³/h]	17 – 58
SOUND PRESSURE LEVEL [dB(A)], distance 2 m	14 – 37
STANDARD SOUND LEVEL DIFFERENCE $D_{n,e,w}$ [dB]	--
FLAIR INNER COVER DIMENSIONS [W x H, mm]	233 x 233
TOP HOOD DIMENSIONS [Ø x H, mm]	159 x 880

MINIMUM WALL THICKNESS [mm]	270
WALL OPENING DIAMETER [mm]	180
WALL MOUNTING SLEEVE DIAMETER [mm]	160
POWER CONSUMPTION [W]	1 – 3
VOLUME-FLOW-RELATED POWER CONSUMPTION [W/(m³/h)]	0.15
INGRESS PROTECTION	IP20
INPUT VOLTAGE [V DC]	6 – 16
ENERGY EFFICIENCY CLASS	A+ / A

iv-Smart+ Silt sectional drawing side view

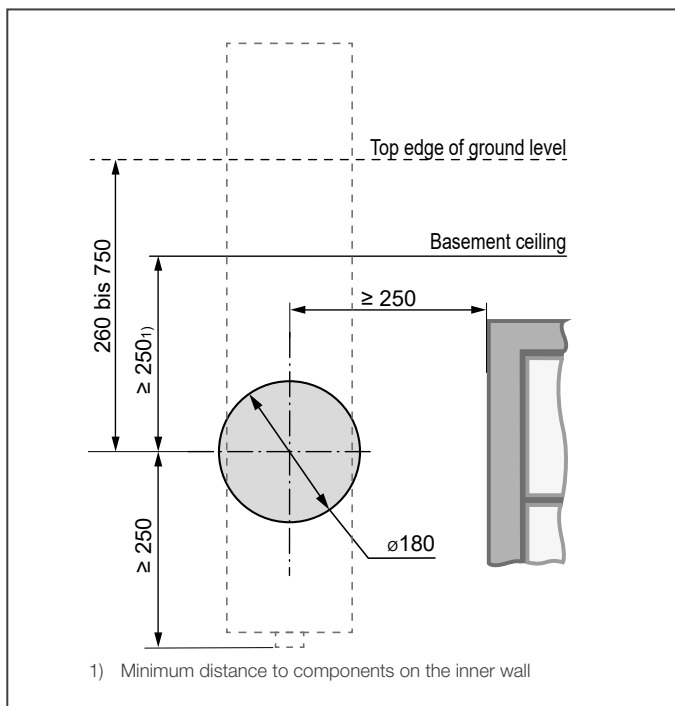
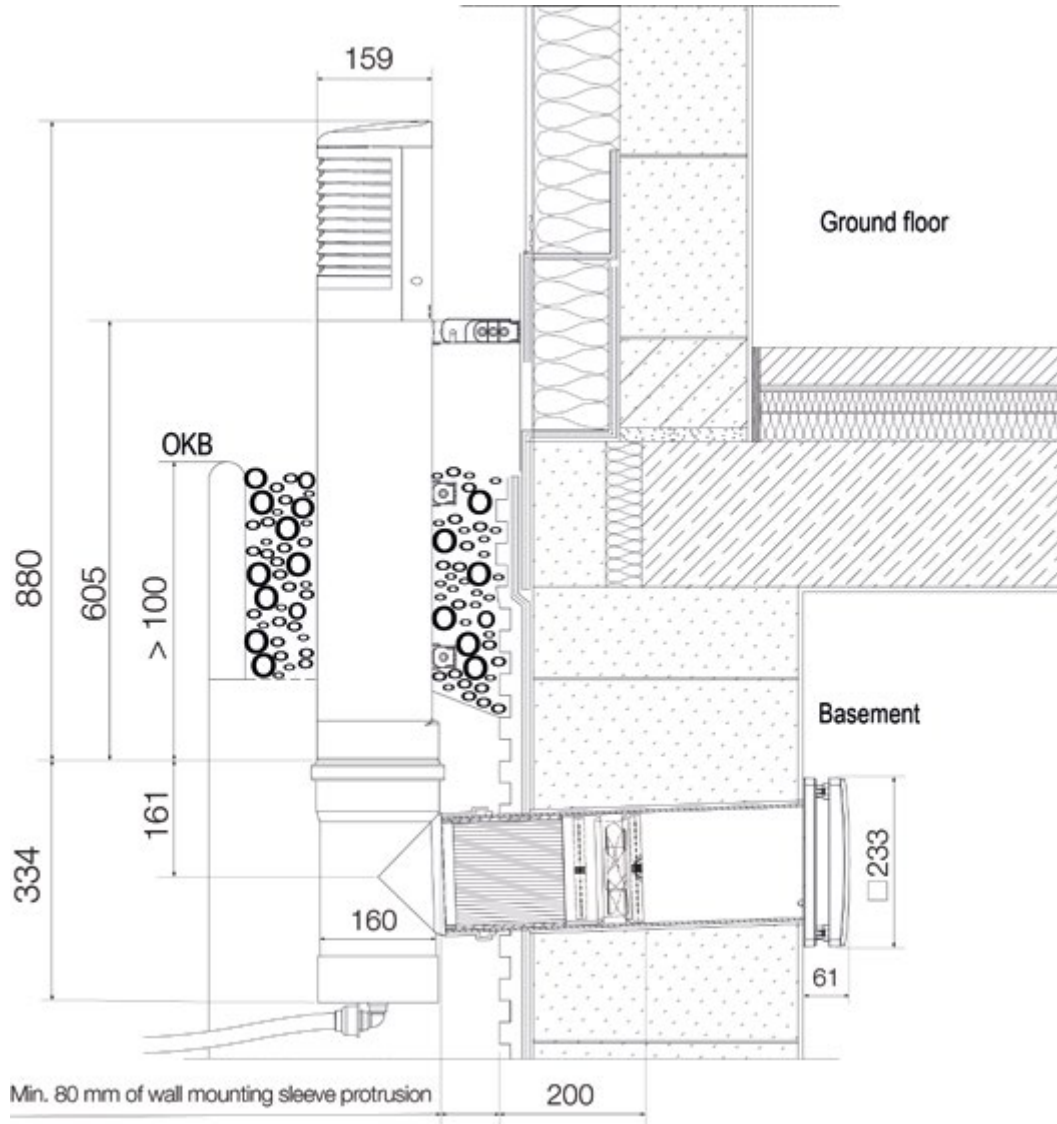

Remarks

During installation, observe the minimum distances in the illustration on the left to ensure that the system can be installed.

Minimum wall thickness: 270 mm.

Pay attention to backwater levels and drainage possibility
The slat openings of the top hood protrude above the usual local snow depths.

All assembly and operating instructions as well as further information can be found at www.inventer.de.



DXF / DWG / STP

inVENTer iV-Smart+ Top



iV-Smart+ Top complete system interior view

Decentralised ventilation system with heat recovery.
Five-year manufacturer's warranty. For attic flats as installation in sloping roofs. Complete system for easy integration by means of a roof duct.
External control via controller.

Minimal operating costs thanks to low power consumption of 3 W and the possibility of user maintenance.

Roof passage in red/black for an inclination angle of 25–45 degrees as optional accessory. Alternatively, relevant brick design for the passage on site.

Components

- Insert with ceramic honeycomb heat accumulator
- inVENTron®: Xenion® reversing fan with temperature monitor and wind pressure stabilizer, embedded in double air fin for flow rectification. Fan meets S3 classification according to DIN EN 13141-8.
- Inner cover with G4 filter (ISO Coarse 60%), wall mounting sleeve with evaporating pantile and roof duct, weather protection hood with collar and driving-rain-proof hood

Controller

- MZ-Home, sMove s4/s8, controller system inVENTer Connect

Accessories (optional)

- Pollen filter, activated carbon filter, hygiene filter
- Sound insulation accessories



Technical specifications

HEAT RECOVERY [%]	87
AIR VOLUME FLOW PER UNIT [m³/h]	8.5 – 29
EXHAUST AIR VOLUME FLOW PER UNIT [m³/h]	17 – 58
SOUND PRESSURE LEVEL [dB(A)], distance 2 m	14 – 37
STANDARD SOUND LEVEL DIFFERENCE $D_{n,e,w}$ [dB]	41 – 45
FLAIR INNER COVER DIMENSIONS [W x H, mm]	233 x 233
WEATHER PROTECTION HOOD DIMENSIONS [Ø x H, mm]	265 x 380

ROOF PITCH ANGLE	5 – 45°
WALL OPENING DIAMETER [mm]	180
WALL MOUNTING SLEEVE DIAMETER [mm]	160
POWER CONSUMPTION [W]	1 – 3
VOLUME-FLOW-RELATED POWER CONSUMPTION [W/(m³/h)]	0.15
INGRESS PROTECTION	IP20
INPUT VOLTAGE [V DC]	6 – 16
ENERGY EFFICIENCY CLASS	A+ / A

iV-Smart+ Top sectional drawing side view

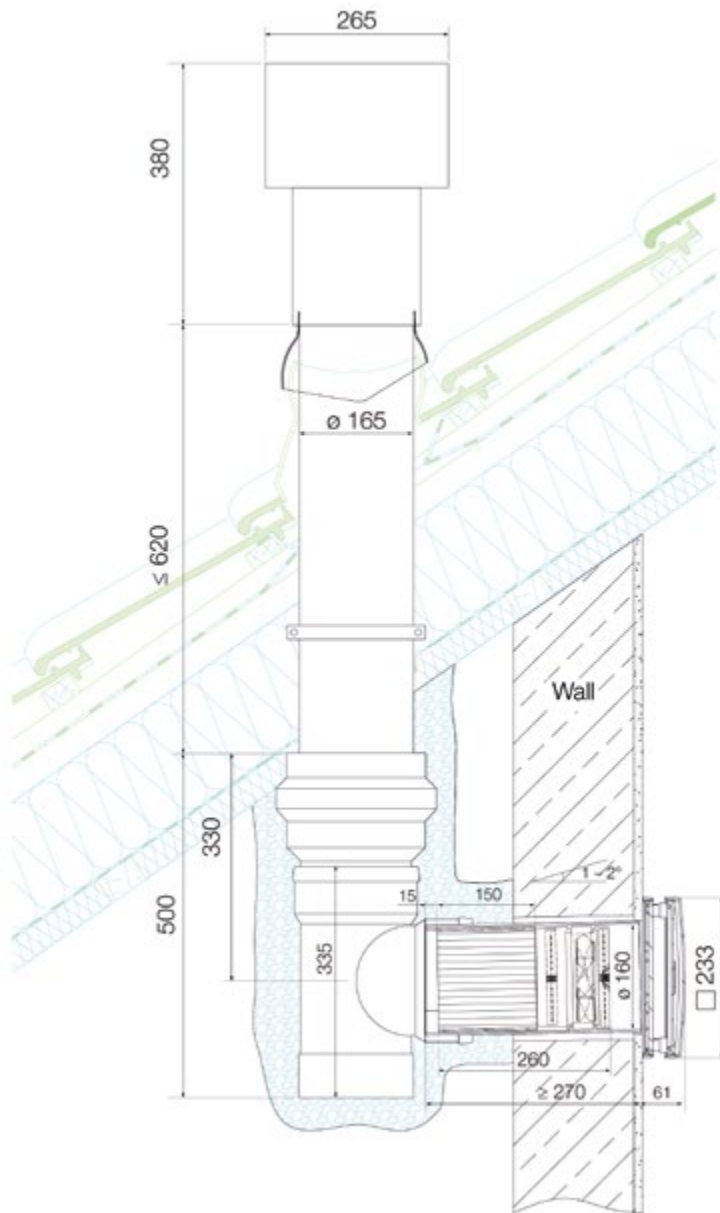

Mounting situation schematic
iV-Smart+ Top side view

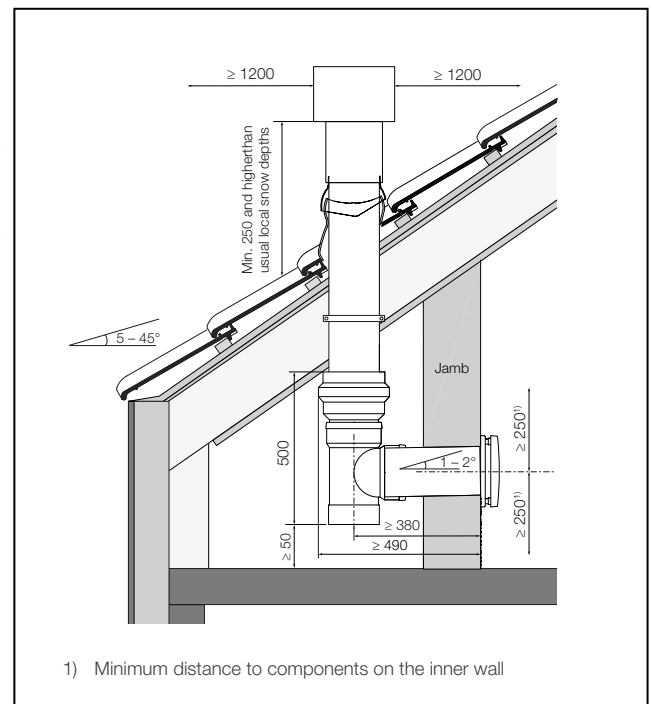

Remarks

When installing, observe the minimum distances in the illustration above to ensure that the system can be installed.

Insert through pan D160 or universal through passage on site.

The openings of the outer hoods must exceed the usual local snow heights.

Wall mounting sleeves located in unheated areas (e.g. behind the jamb) must be insulated at the appropriate points.

Centre of wall opening in jamb and top hood vertical.

Minimum distances from centre axis core bore

- to components on the inner wall/reveal: 250 mm circumferential
- to components on the outer wall 250 mm circumferential
- between two ventilation units in the same room: 1.2 m
- to other ventilation systems in the external area: 1.2 m

All assembly and operating instructions as well as further information can be found at www.inventer.de



DXF / DWG / STP

inVENTer iV14-Zero



iV14-Zero complete system interior view

Decentralised ventilation system with heat recovery.

Five-year manufacturer's warranty.

Noise protection device for renovation and retrofitting.

Complete system for easy integration into the outer wall.

- Standard sound level difference of up to 56 dB with the Inventin® insert
- At Level 1: Sound pressure level only 10 dB(A)
- Patented inVENTron® technology: 87% heat recovery

External control via controller.

Quick installation with Simplex: Installation block with pre-installed wall installation sleeve, integrated slope.

Components

- Insert with ceramic honeycomb heat accumulator and Inventin® sound insulation insert
- inVENTron®: Xenion® reversing fan with temperature monitor and wind pressure stabilizer, embedded in double air fin for flow rectification. Fan meets S3 classification according to DIN EN 13141-8.
- Inner cover with G4 filter (ISO Coarse 60%), wall mounting sleeve, driving-rain-proof weather protection hood

Controller

- MZ-Home, sMove s4/s8, controller system inVENTer Connect

Accessories (optional)

- Pollen filter, activated carbon filter, hygiene filter
- D230 or Simplex R-D200 wall mounting block
- Sound and wind protection accessories

iV14-Zero external cover

Flex weather protection hood

White: RAL9016

Grey: RAL9006

Anthracite: RAL7016

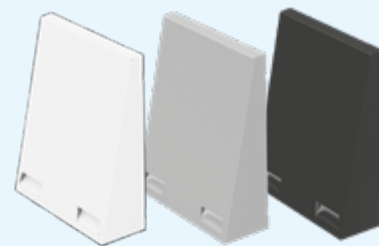

iV14-Zero internal cover

Flair Zero inner cover

(RAL9010)



Technical specifications

HEAT RECOVERY [%]	87
AIR VOLUME FLOW PER UNIT [m³/h]	8.5 – 29
EXHAUST AIR VOLUME FLOW PER UNIT [m³/h]	17 – 58
SOUND PRESSURE LEVEL [dB(A)], distance 2 m	10 – 31
STANDARD SOUND LEVEL DIFFERENCE $D_{n,e,w}$ [dB]	48 – 56
FLAIR INNER COVER DIMENSIONS [W x H, mm]	233 x 233
WEATHER PROTECTION HOOD DIMENSIONS [W x H, mm]	279 x 313

MINIMUM WALL THICKNESS [mm]	255
WALL OPENING DIAMETER [mm]	225
WALL MOUNTING SLEEVE DIAMETER [mm]	200
POWER CONSUMPTION [W]	1 – 3
VOLUME-FLOW-RELATED POWER CONSUMPTION [W/(m³/h)]	0.15
INGRESS PROTECTION	IP20
INPUT VOLTAGE [V DC]	6 – 16
ENERGY EFFICIENCY CLASS	A+ / A

Installation scheme iV14-Zero

► The installation scheme with IB Connect UP/AP can be found in the „inVENTer Connect controller platform“ subsection.

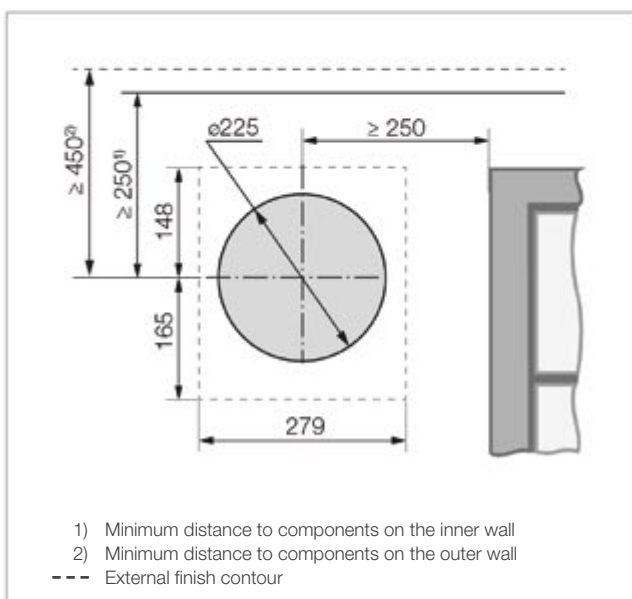
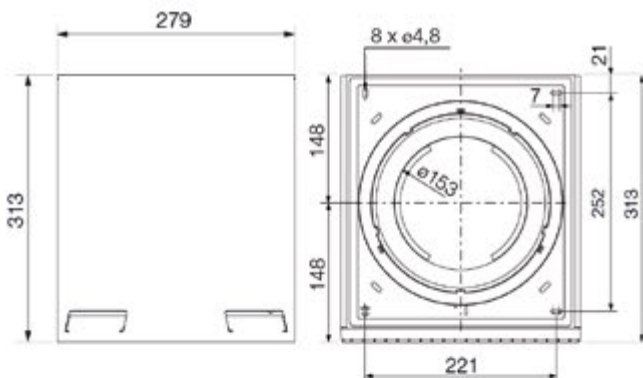
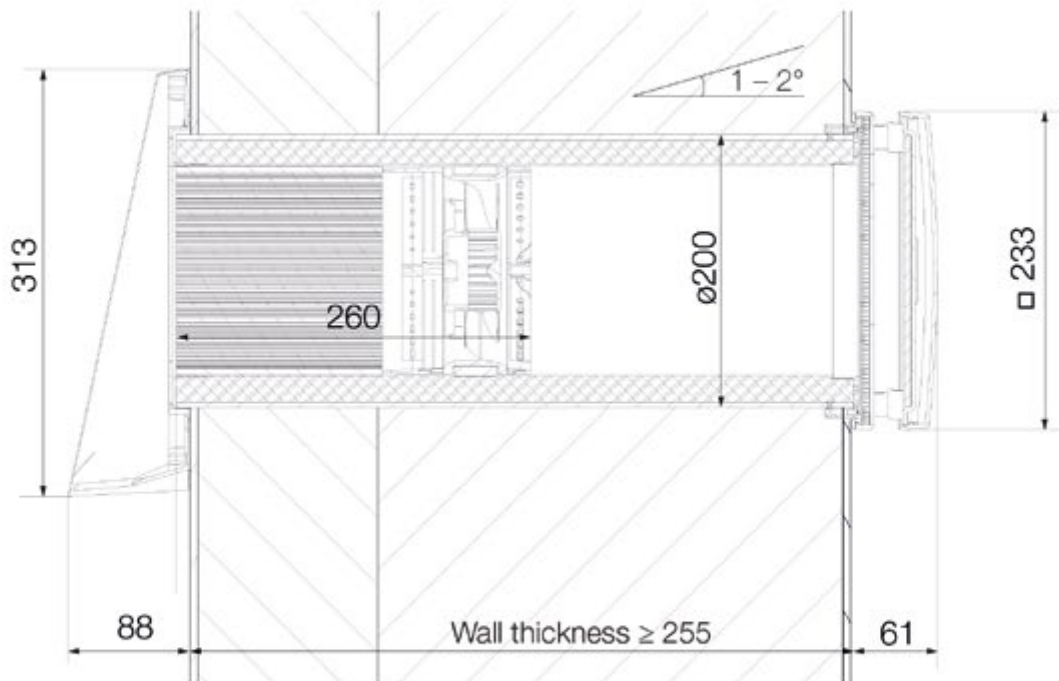

Remarks

To ensure that the system can be installed, observe the minimum clearances shown in the adjacent illustration.
 Minimum wall thickness: 255 mm.

Minimum distances from centre axis core bore

- to components on the inner wall/reveal: 250 mm circumferential
- to components on the outer wall 250 mm circumferential 250 mm (left, right, bottom) or 450 mm (top); mind lintels, reveal edges, insulation thickness, and any shutters
- between two ventilation units in the same room: 1.2 m.
- to other ventilation systems in the external area: 1.2 m.
- Recommendation: Mount the upper edge of the weather protection hood at the height of the lower edge of the lintel (optics on the facade).
- Mount in the room air volume flow at about 1.80 m above the upper edge of the finished floor.

All assembly and operating instructions and further information can be found at www.inventer.de.



DXF / DWG / STP

inVENTer iV14-Zero Corner



iV14-Zero Corner inside complete system

Decentralised ventilation system with heat recovery.
Five-year manufacturer's warranty. Noise protection device for renovation and retrofitting with Corner duct as reveal variant.

Complete system for easy integration into the outer wall.

- Standard sound level difference of up to 60 dB with the Inventin® insert
- At Level 1: Sound pressure level only 10 dB(A)
- Patented inVENTron® technology: 87% heat recovery

External control via controller.

Quick installation with Simplex: Installation block with pre-installed wall installation sleeve, integrated slope.

Components

- Insert with ceramic honeycomb heat accumulator and Inventin® sound insulation insert
- inVENTron®: Xenion® reversing fan with temperature monitor and wind pressure stabilizer, embedded in double air fin for flow rectification. Fan meets S3 classification according to DIN EN 13141-8.
- Inner cover with G4 filter (ISO Coarse 60%), wall mounting sleeve, Corner flat duct with integrated slope (including reveal grille)

Controller

- MZ-Home, sMove s4/s8, controller system inVENTer Connect

Accessories (optional)

- D200 substructure board
- Pollen filter, activated carbon filter, hygiene filter
- D230 or Simplex R-D200 wall mounting block
- Sound and wind protection accessories

Technical specifications

HEAT RECOVERY [%]	87
AIR VOLUME FLOW PER UNIT [m³/h]	8.5 – 29
EXHAUST AIR VOLUME FLOW PER UNIT [m³/h]	17 – 58
SOUND PRESSURE LEVEL [dB(A)], distance 2 m	10 – 31
STANDARD SOUND LEVEL DIFFERENCE $D_{n,e,w}$ [dB]	55 – 60
FLAIR INNER COVER DIMENSIONS [W x H, mm]	233 x 233
REVEAL GRILLE DIMENSIONS [W x H, mm]	70 x 512



MINIMUM WALL THICKNESS/INSULATION [mm]	> 270/> 70
WALL OPENING DIAMETER [mm]	225
WALL MOUNTING SLEEVE DIAMETER [mm]	200
POWER CONSUMPTION [W]	1 – 3
VOLUME-FLOW-RELATED POWER CONSUMPTION [W/(m³/h)]	0.15
INGRESS PROTECTION	IP20
INPUT VOLTAGE [V DC]	6 – 16
ENERGY EFFICIENCY CLASS	A+ / A

Installation scheme
iV14-Zero Corner, top view

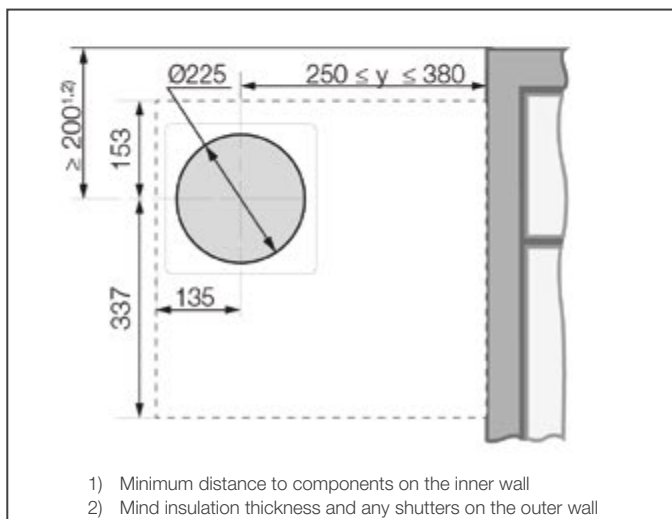
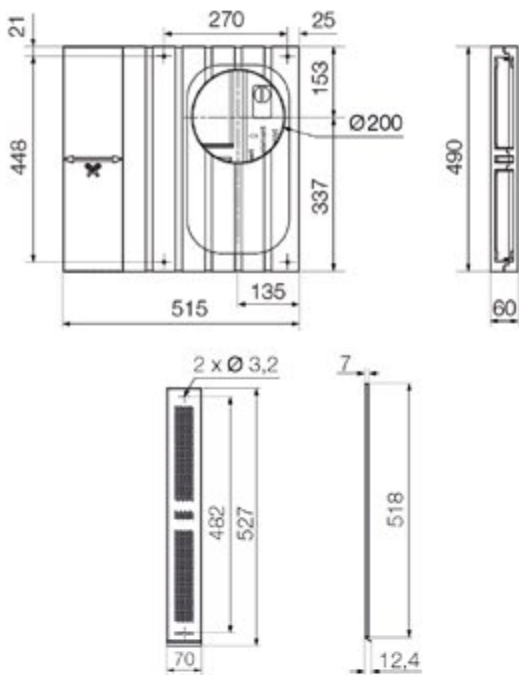
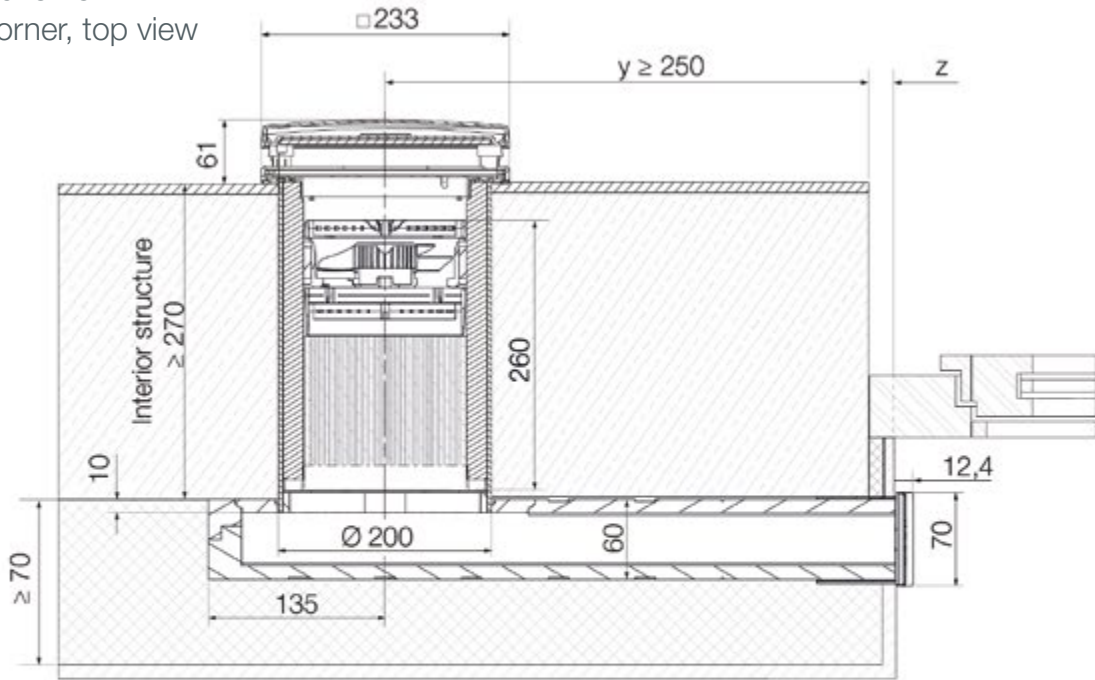

Remarks

When installing, observe the minimum distances in order to ensure that the system can be installed and functions properly. Minimum internal structure: When installing, observe the minimum distances in order to ensure that the system can be installed and functions properly. The flat duct can be underlaid with insulating material (such as the inVENTer UBP Corner substructure board).

Minimum distances from centre axis core bore

- Insulation thickness on flat duct: > 10 mm
- to reveal (outside): 250 – 380 mm
- to components on the outer wall/intel: 200 mm; mind insulation thickness and any shutters
- between two ventilation units in the same room: 1.2 m
- to other ventilation systems in the external area: 1.2 m
- Installation length of the flat duct:
 $L = (y + z) + 135$, where $250 \leq (y+z) \leq 380$

All assembly and operating instructions and further information can be found at www.inventer.de.



DXF / DWG / STP

inVENTer iV14-Zero Nordic

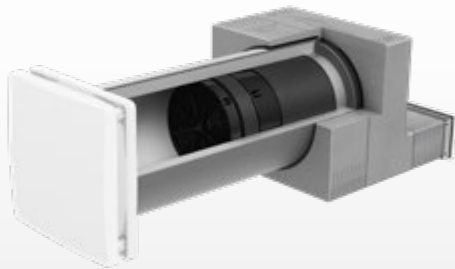

iV14-Zero Nordic complete system interior view

Decentralised ventilation system with heat recovery.
 Five-year manufacturer's warranty. Noise protection device for new construction and renovation with external finish flush with the facade for easy integration into clinker facades or exterior walls with insulation.
 External control via controller.

Minimal operating costs thanks to low power consumption of 3 W and the possibility of user maintenance.

Quick installation with Simplex: Installation block with pre-installed wall installation sleeve, integrated slope.

Components

- Insert with ceramic honeycomb heat accumulator and Inventin® sound insulation insert
- inVENTron®: Xenion® reversing fan with temperature monitor and wind pressure stabilizer, embedded in double air fin for flow rectification. Fan meets S3 classification according to DIN EN 13141-8.
- Inner cover with G4 filter (ISO Coarse 60%), wall mounting sleeve
- Nordic facade end (including outer grille)

Controller

- MZ-Home, sMove s4/s8, controller system inVENTer Connect

Accessories (optional)

- Pollen filter, activated carbon filter, hygiene filter
- D230 or Simplex R-D200 wall mounting block
- Soundproofing accessories



Technical specifications

HEAT RECOVERY [%]	87
AIR VOLUME FLOW PER UNIT [m³/h]	8.5 – 29
EXHAUST AIR VOLUME FLOW PER UNIT [m³/h]	17 – 58
SOUND PRESSURE LEVEL [dB(A)], distance 2 m	10 – 31
STANDARD SOUND LEVEL DIFFERENCE $D_{n,e,w}$ [dB]	49 – 55
FLAIR INNER COVER DIMENSIONS [W x H, mm]	233 x 233
OUTER GRILLE DIMENSIONS [W x H, mm]	280 x 86
WALL OPENING DIAMETER [mm]	225
WALL MOUNTING SLEEVE DIAMETER [mm]	200

MINIMUM WALL THICKNESS [mm]	250
+ INSULATION (INCL. GAP AS REQUIRED) [mm]	>120
+ ANY CLINKER [mm]	115
TOTAL WALL, CLINKER/THERMAL INSULATION SYSTEM [mm]	> 475/> 370
POWER CONSUMPTION [W]	1 – 3
VOLUME-FLOW-RELATED POWER CONSUMPTION [W/(m³/h)]	0.15
INGRESS PROTECTION	IP20
INPUT VOLTAGE [V DC]	6 – 16
ENERGY EFFICIENCY CLASS	A+ / A

Installation scheme for double-shell masonry with facing bricks (clinker)

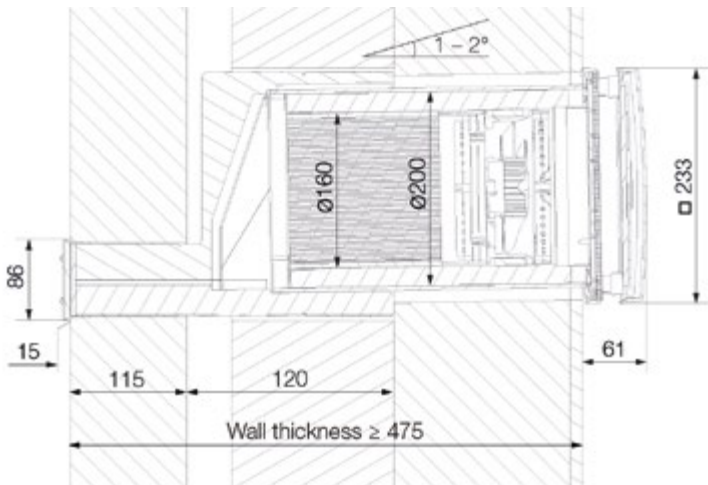

Installation scheme for single-shell masonry with thermal insulation system

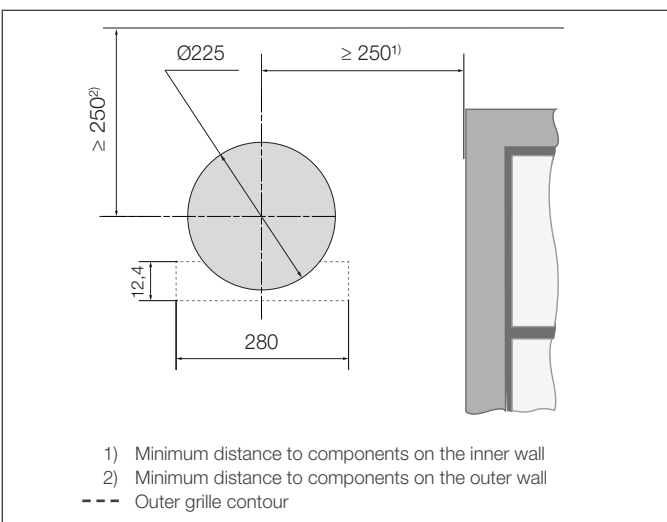
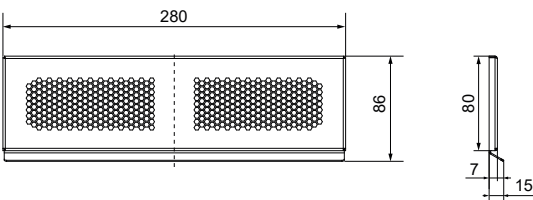
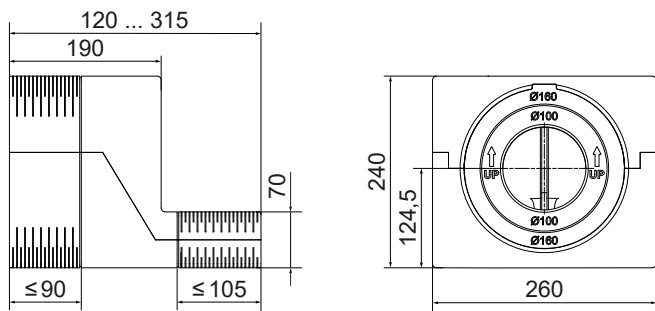
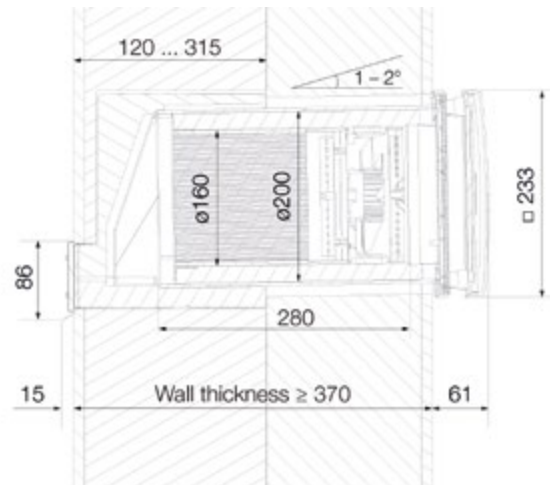

Remarks

When installing, observe the minimum distances in order to ensure that the system can be installed and functions properly.

Minimum overall wall thickness for clinker: 475 mm

Minimum overall wall thickness for thermal insulation system: 370 mm

Minimum insulation thickness including gap as required: 120 mm

Minimum distances from centre axis core bore

- to components on the inner wall/reveal: 250 mm circumferential
- to components on the outer wall 250 mm circumferential; mind lintels, reveal edges, insulation thickness, and any shutters
- between two ventilation units in the same room: 1.2 m
- to other ventilation systems in the external area: 1.2 m
- Mount in the room air volume flow at about 1.80 m above the upper edge of the finished floor

All assembly and operating instructions and further information can be found at www.inventer.de.



DXF / DWG / STP

inVENTer iV-Twin+



iV-Twin+ complete system interior view

Decentralised ventilation system with 94% heat recovery.
Five-year manufacturer's warranty.

Single-room unit for separate ventilation of individual rooms
or as a complementary system with concealed external finish
for easy integration into outer walls with outer wall insulation.

Does not require pairwise operation.

External control via controller. Control via separate controller
or dedicated ventilation zone is recommended.

Components

- 2 highly efficient ceramic heat accumulators in half cylinder design
- 2 Mini-Xenion® reversing fans in half cylinder design, each with temperature monitor and wind pressure stabilizer, including 2 G3 filters (ISO Coarse 45%)
- Wall mounting sleeve with vertical air volume flow separation
- Inner cover with vertical air volume flow separation
- Driving rain proof weather protection hood with air volume flow separation wall mounting sleeve with vertical air volume flow separation

Controller

- MZ-Home, sMove s4/s8

Accessories (optional)

- Pollen filter, activated carbon filter
- Sound insulation accessories
- Wall mounting block D230 or Simplex R-D200

iV-Twin+ external cover

Weather protection hood Flex Twin+

White: RAL9016
Grey: RAL9006
Anthracite: RAL7016

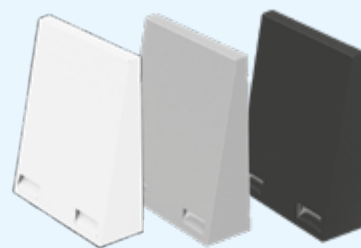

iV-Twin+ internal cover

Flair Twin+ inner cover
(RAL9010)



Technical specifications

HEAT RECOVERY [%]	94
AIR VOLUME FLOW PER UNIT [m³/h]	5 – 23
EXHAUST AIR VOLUME FLOW PER UNIT [m³/h]	10 – 45
SOUND PRESSURE LEVEL [dB(A)], distance 2 m	14 – 38
STANDARD SOUND LEVEL DIFFERENCE $D_{n,e,w}$ [dB]	45 – 56
FLAIR INNER COVER DIMENSIONS [W x H, mm]	233 x 233
WEATHER PROTECTION HOOD DIMENSIONS [W x H, mm]	279 x 313

MINIMUM WALL THICKNESS [mm]	270
WALL OPENING DIAMETER [mm]	225
WALL MOUNTING SLEEVE DIAMETER [mm]	200
POWER CONSUMPTION [W]	0.5 – 3
VOLUME-FLOW-RELATED POWER CONSUMPTION [W/(m³/h)]	0.18
INGRESS PROTECTION	IPX4
INPUT VOLTAGE [V DC]	6 – 16
ENERGY EFFICIENCY CLASS	A+ / A

Installation scheme iV-Twin+, top view

► The installation scheme with IB Connect UP/AP can be found in the „inVENTer Connect controller platform“ subsection.

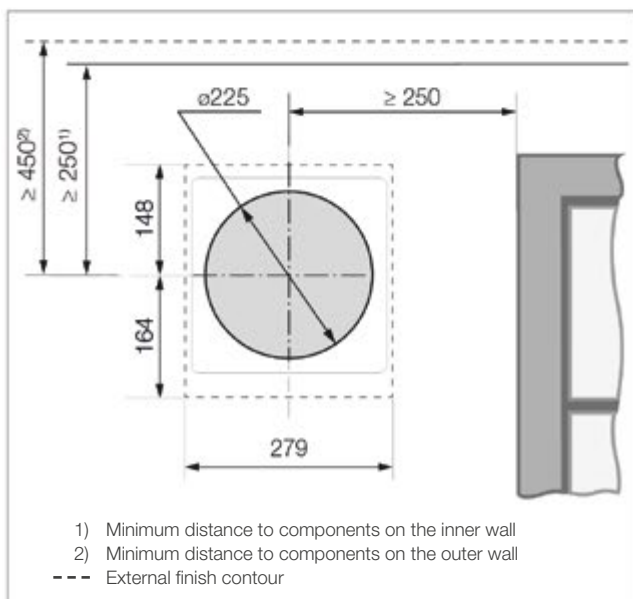
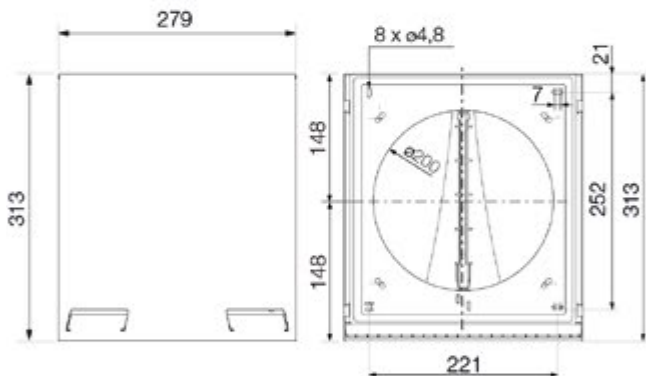
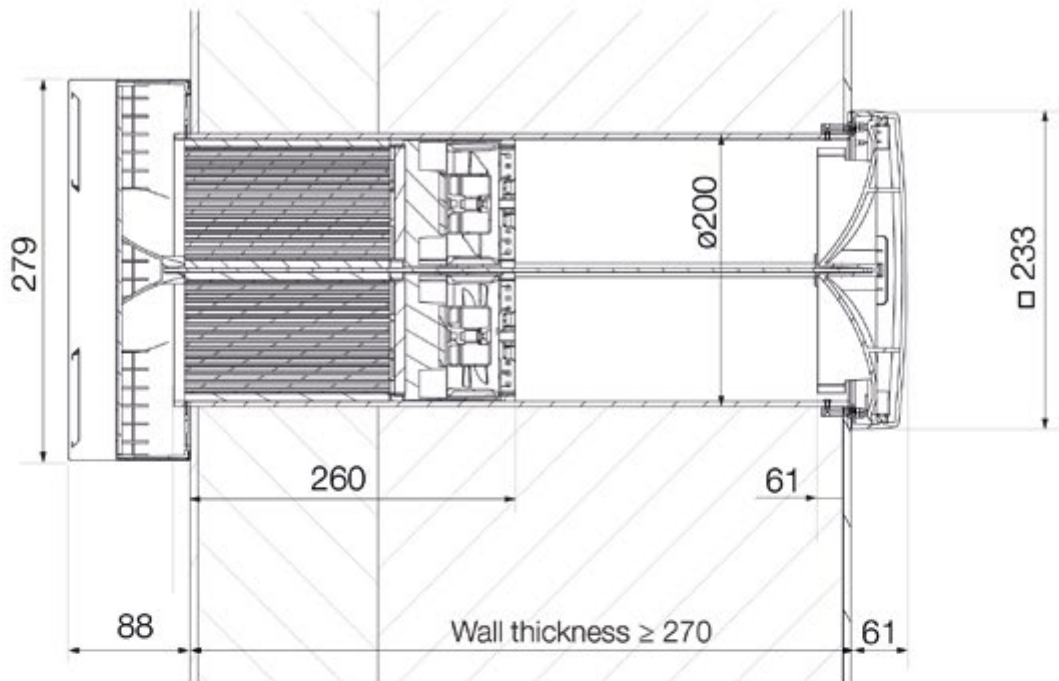

Remarks

To ensure that the system can be installed, observe the minimum clearances shown in the adjacent illustration.
 Minimum wall thickness: 270 mm.

Minimum distances from centre axis core bore

- to components on the inner wall/reveal: 250 mm circumferential
- to components on the outer wall 250 mm circumferential 250 mm (left, right, bottom) or 450 mm (top); mind lintels, reveal edges, insulation thickness, and any shutters
- between two ventilation units in the same room: 1.2 m
- to other ventilation systems in the external area: 1.2 m
- Recommendation: Mount the upper edge of the weather protection hood at the height of the lower edge of the lintel (optics on the facade)
- Mount in the room air volume flow at about 1.80 m above the upper edge of the finished floor

All assembly and operating instructions and further information can be found at www.inventer.eu.



DXF / DWG / STP

inVENTer iV-Twin+ Corner

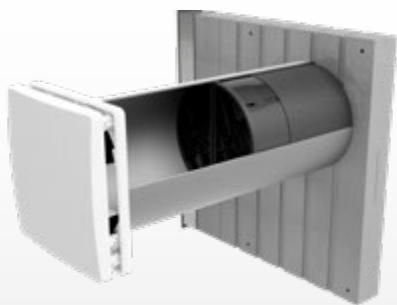

iV-Twin+ Corner complete system interior view

Decentralised ventilation system with heat recovery.
Five-year manufacturer's warranty. Compact single-room unit for new construction and renovation as reveal variant with concealed external finish for easy integration into outer walls with outer wall insulation. No paired operation necessary. External control via controller.

Minimal operating costs thanks to low power consumption of 3 W and the possibility of user maintenance.

Quick installation with Simplex: Installation block with pre-installed wall installation sleeve, integrated slope.

Components

- 2 highly efficient ceramic heat accumulators in half cylinder design
- 2 Mini-Xenion® reversing fans in half cylinder design, each with temperature monitor and wind pressure stabilizer, including 2 G3 filters (ISO Coarse 45%)
- Wall mounting sleeve with vertical air volume flow separation
- Inner cover with vertical air volume flow separation
- Corner flat duct with integrated slope and air volume flow separation (including reveal grille)

Controller

- MZ-Home, sMove s4/s8

Accessories (optional)

- D200 substructure board
- Pollen filter, activated carbon filter
- D230 or Simplex R-D200 wall mounting block
- Sound and wind protection accessories



Technical specifications

HEAT RECOVERY [%]	94
AIR VOLUME FLOW PER UNIT [m³/h]	5 – 23
EXHAUST AIR VOLUME FLOW PER UNIT [m³/h]	10 – 45
SOUND PRESSURE LEVEL [dB(A)], distance 2 m	14 – 38
STANDARD SOUND LEVEL DIFFERENCE $D_{n,e,w}$ [dB]	50 – 57
FLAIR INNER COVER DIMENSIONS [W x H, mm]	233 x 233
SOFFIT GRILLE DIMENSIONS [W x H, mm]	70 x 527

MINIMUM WALL THICKNESS/INSULATION [mm]	> 270 / > 70
WALL OPENING DIAMETER [mm]	225
WALL MOUNTING SLEEVE DIAMETER [mm]	200
POWER CONSUMPTION [W]	0.5 – 3
VOLUME-FLOW-RELATED POWER CONSUMPTION [W/(m³/h)]	0.18
INGRESS PROTECTION	IP X4
INPUT VOLTAGE [V DC]	6 – 16
ENERGY EFFICIENCY CLASS	A+ / A

Installation scheme iV-Twin+ Corner, top view

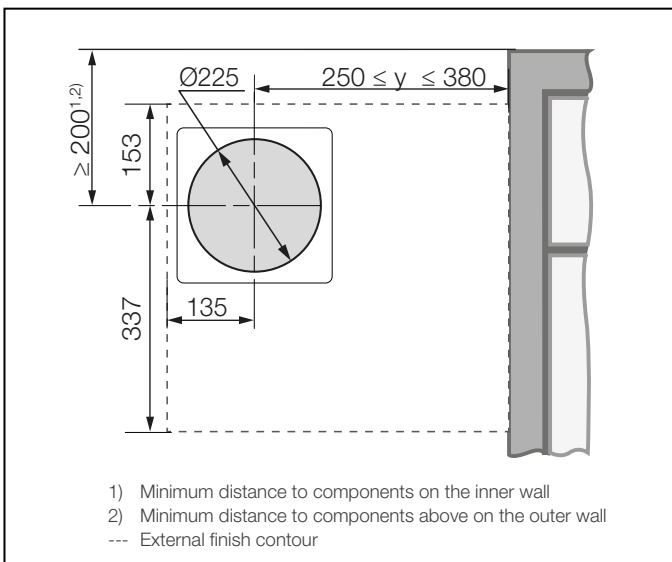
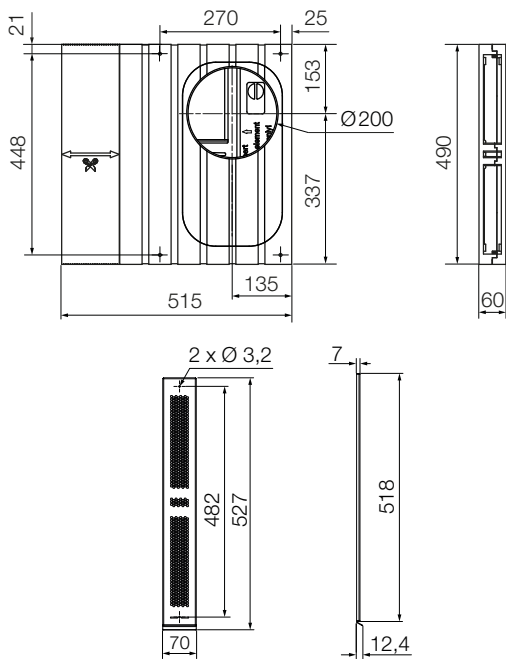
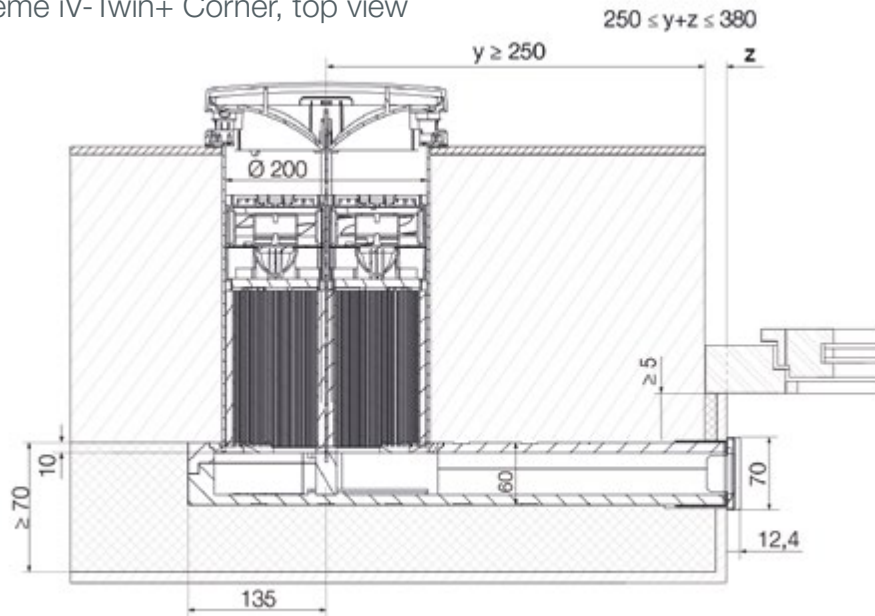

Remarks

When installing, observe the minimum distances in order to ensure that the system can be installed and functions properly. Minimum internal structure: When installing, observe the minimum distances in order to ensure that the system can be installed and functions properly. The flat duct can be underlaid with insulating material (such as the inVENTer UBP Corner substructure board).

Minimum distances from centre axis core bore

- Insulation thickness on flat duct: > 10 mm
- to reveal (outside): 250 – 380 mm
- to components on the outer wall/intel: 200 mm; mind insulation thickness and any shutters
- between two ventilation units in the same room: 1.2 m
- to other ventilation systems in the external area: 1.2 m
- Installation length of the flat duct:
 $L = (y + z) + 135$, where $250 \leq (y + z) \leq 380$

All assembly and operating instructions and further information can be found at www.inventer.de.



DXF / DWG / STP

inVENTer iV-Twin+ Nordic



iV-Twin+ Nordic complete system interior view

Decentralised ventilation system with heat recovery.
 Five-year manufacturer's warranty. Compact single-room unit for ventilating individual rooms or as a complementary system for easy integration into clinker facades or outer walls with insulation. No paired operation necessary.
 External control via controller.

Minimal operating costs thanks to low power consumption of 3 W and the possibility of user maintenance.

Quick installation with Simplex: Installation block with pre-installed wall installation sleeve, integrated slope.

Components

- 2 highly efficient ceramic heat accumulators in half cylinder design
- 2 Mini-Xenion® reversing fans in half cylinder design, each with temperature monitor and wind pressure stabilizer, including 2 G3 filters (ISO Coarse 45%)
- Wall mounting sleeve with vertical air volume flow separation
- Inner cover with vertical air volume flow separation
- Nordic facade end (including outer grille)

Controller

- MZ-Home, sMove s4/s8

Accessories (optional)

- Pollen filter, activated carbon filter
- D230 or Simplex R-D200 wall mounting block
- Soundproofing accessories



Technical specifications

HEAT RECOVERY [%]	94
AIR VOLUME FLOW PER UNIT [m³/h]	5 – 23
EXHAUST AIR VOLUME FLOW PER UNIT [m³/h]	10 – 45
SOUND PRESSURE LEVEL [dB(A)], distance 2 m	14 – 38
STANDARD SOUND LEVEL DIFFERENCE $D_{n,e,w}$ [dB]	45 – 53
FLAIR INNER COVER DIMENSIONS [W x H, mm]	233 x 233
OUTER GRILLE DIMENSIONS [W x H, mm]	280 x 86
WALL OPENING DIAMETER [mm]	225
WALL MOUNTING SLEEVE DIAMETER [mm]	200

MINIMUM WALL THICKNESS [mm]	250
+ INSULATION (INCLUDING ANY GAP) [mm]	> 120
+ ANY CLINKER [mm]	115
TOTAL WALL, CLINKER / THERMAL INSULATION SYSTEM [mm]	> 475 / > 370
POWER CONSUMPTION [W]	0.5 – 3
VOLUME-FLOW-RELATED POWER CONSUMPTION [W/(m³/h)]	0.16
INGRESS PROTECTION	IP20
INPUT VOLTAGE [V DC]	6 – 16
ENERGY EFFICIENCY CLASS	A+ / A

Installation scheme for double-shell masonry with facing bricks (clinker) – top view

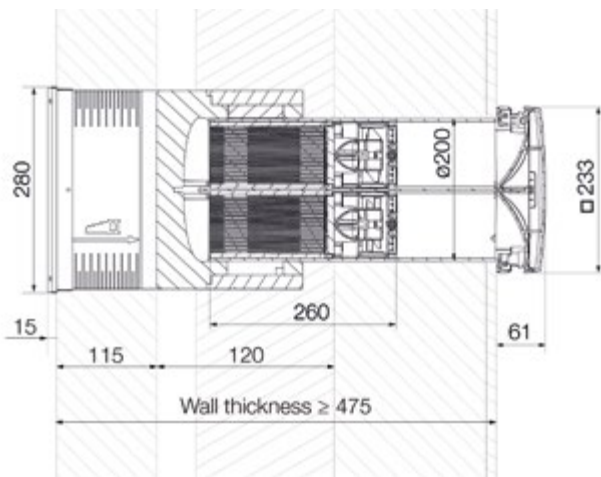

Installation scheme for single-shell masonry with Thermal insulation system – top view

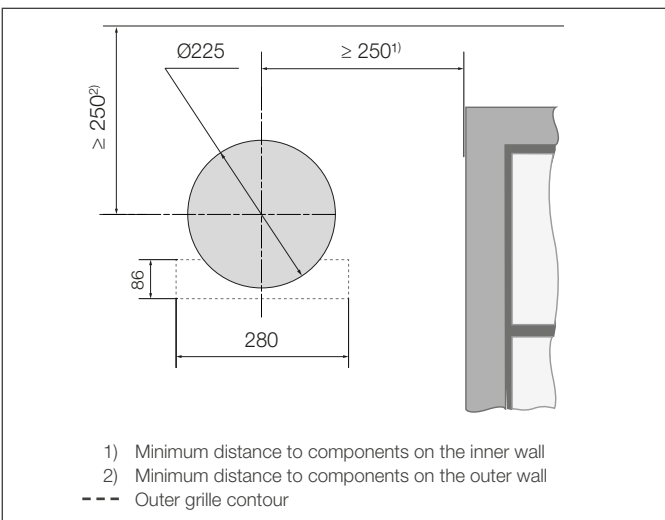
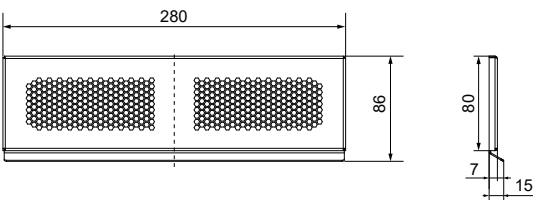
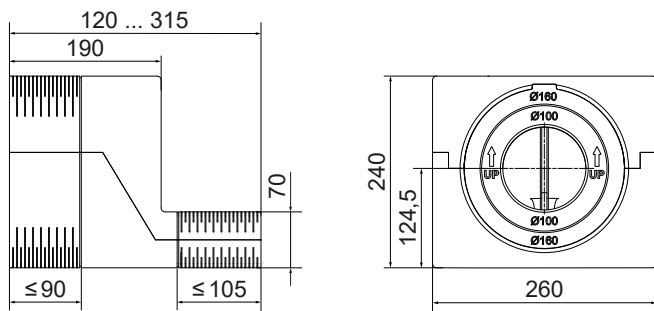
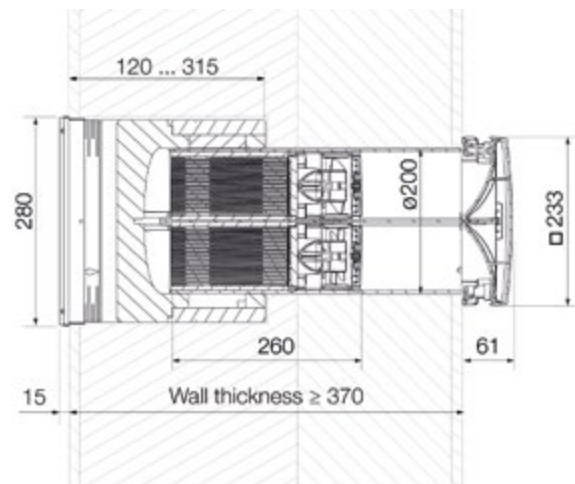

Remarks

When installing, observe the minimum distances in order to ensure that the system can be installed and functions properly.

Minimum overall wall thickness for clinker: 475 mm

Minimum overall wall thickness for thermal insulation system: 370 mm

Minimum insulation thickness including gap as required: 120 mm

Minimum distances from centre axis core bore

- to components on the inner wall/reveal: 250 mm circumferential
- to components on the outer wall 250 mm circumferential; mind lintels, reveal edges, insulation thickness, and any shutters
- between two ventilation units in the same room: 1.2 m
- to other ventilation systems in the external area: 1.2 m
- Mount in the room air volume flow at about 1.80 m above the upper edge of the finished floor

All assembly and operating instructions and further information can be found at www.inventer.de.



DXF / DWG / STP

inVENTer iV-Light



Decentralised ventilation system with heat recovery.
Five-year manufacturer's warranty.

Complete device for new construction and renovation for easy integration into outer walls.
External control via controller.

Quick installation with Simplex: Installation block with pre-installed wall installation sleeve, integrated slope

Minimal operating costs thanks to low power consumption of 3 W and the possibility of user maintenance.

Components

- Insert with ceramic honeycomb regenerator
- inVENTron®: Xenion® reversing fan with temperature monitor and wind pressure stabilizer, embedded in a double air fin for flow rectification, fans meet S3 classification according to DIN EN 13141-8, including G4 filter (ISO Coarse 60%)
- Wall mounting sleeve
- Internal panel
- Weather protection grille

Controller

- MZ-Home, sMove s4/s8, controller system inVENTer Connect

Accessories (optional)

- Sound and wind protection accessories
- D180 and Simplex R-D160 wall mounting block



Technical specifications

HEAT RECOVERY [%]	84
AIR VOLUME FLOW PER UNIT [m³/h]	5 – 21
EXHAUST AIR VOLUME FLOW PER UNIT [m³/h]	10 – 42
SOUND PRESSURE LEVEL [dB(A)], distance 2 m	14 – 36
STANDARD SOUND LEVEL DIFFERENCE $D_{n,e,w}$ [dB]	34 – 47
LIGHT INNER COVER DIMENSIONS [W x H, mm]	220 x 220
WEATHER PROTECTION HOOD DIMENSIONS [Ø, mm]	200

MINIMUM WALL THICKNESS [mm]	290
WALL OPENING DIAMETER [mm]	180
WALL MOUNTING SLEEVE DIAMETER [mm]	160
POWER CONSUMPTION [W]	1 – 3
VOLUME-FLOW-RELATED POWER CONSUMPTION [W/(m³/h)]	0.2
INGRESS PROTECTION	IP20
INPUT VOLTAGE [V DC]	6 – 16
ENERGY EFFICIENCY CLASS	A+ / A

Installation scheme iV-Light

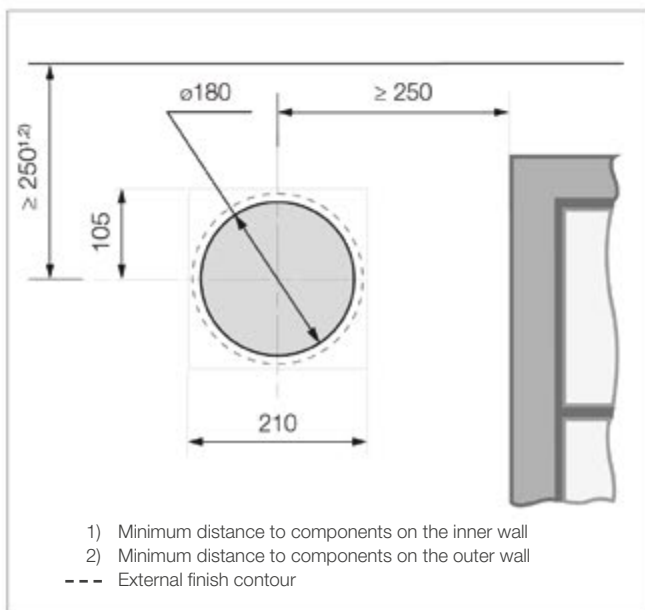
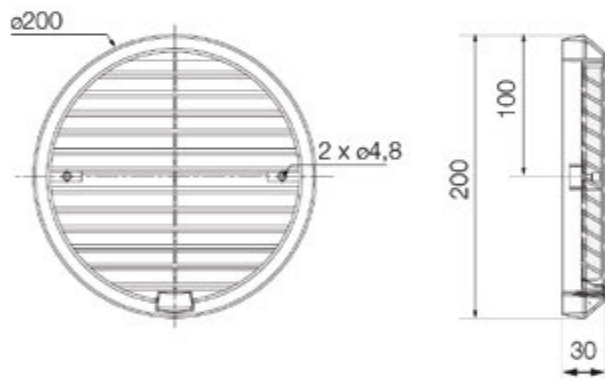
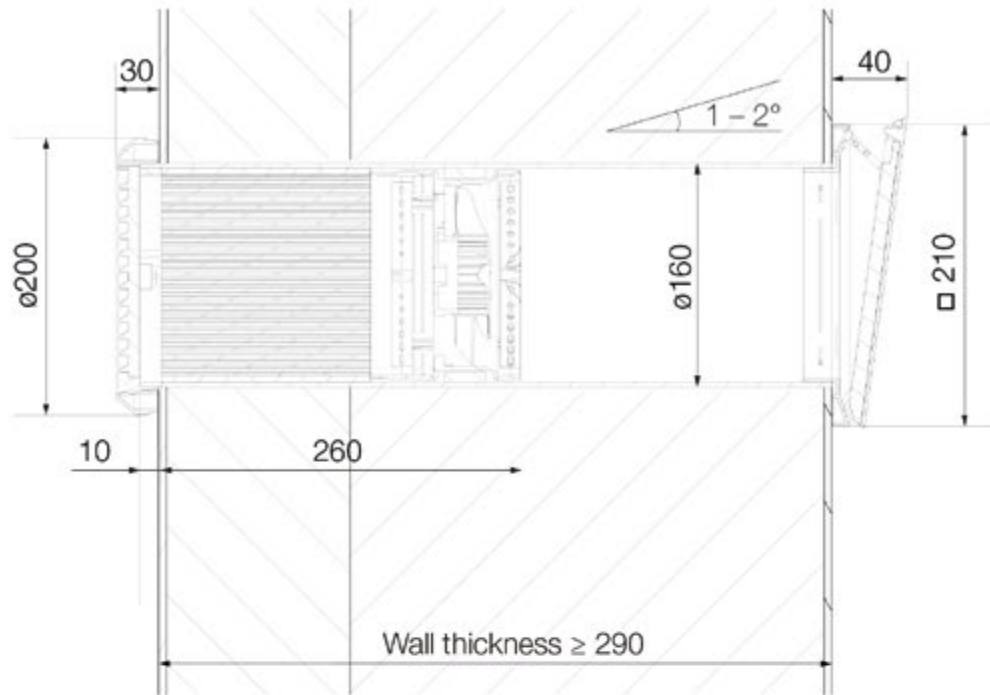

Remarks

To ensure that the system can be installed, observe the minimum clearances shown in the adjacent illustration.
 Minimum wall thickness: 290 mm.

Minimum distances from centre axis core bore

- to components on the inner wall/reveal: 250 mm circumferential
- to components on the outer wall 250 mm circumferential; mind lintels, reveal edges, insulation thickness, and any shutters.
- between two ventilation units in the same room: 1.2 m
- to other ventilation systems in the external area: 1.2 m
- Recommendation: Mount the upper edge of the weather protection hood at the height of the lower edge of the lintel (optics on the facade)
- Mount in the air volume flow of the room at approx. 1.80 m over the upper edge of the finished floor optimally.

All assembly and operating instructions as well as further information can be found at www.inventer.de.



DXF / DWG / STP

inVENTer iV-Compact

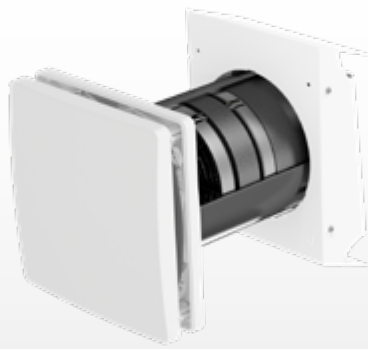

iV-Compact inside complete system

Decentralised ventilation system with heat recovery.
Five-year manufacturer's warranty.

Compact unit for new construction and renovation for easy integration in very thin outer walls (≥ 140 mm).

External control via controller.

Quick installation with Simplex: Installation block with pre-installed wall installation sleeve, integrated slope

Minimal operating costs thanks to low power consumption of 3 W and the possibility of user maintenance.

Components

- Insert with ceramic honeycomb regenerator
- inVENTron®: Xenion® reversing fan with temperature monitor and wind pressure stabilizer, embedded in a double air fin for flow rectification, fans meet S3 classification according to DIN EN 13141-8, including G4 filter (ISO Coarse 60%)
- Wall mounting sleeve
- Internal panel
- Driving rain proof weather protection hood

Controller

- MZ-Home, sMove s4/s8, controller system inVENTer Connect

Accessories (optional)

- Pollen filter
- Sound and wind protection accessories
- Wall mounting block D180 or Simplex R-D160

External cover iV-Compact
Weather protection hood Compact

White: RAL9016
Grey: RAL9006
Anthracite: RAL7016

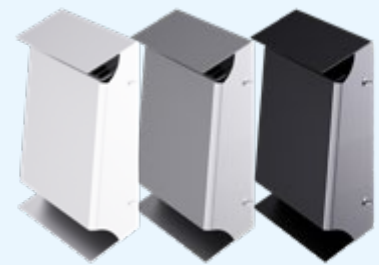

iV-Compact internal cover
Flair inner cover
(RAL9010)



Technical specifications

HEAT RECOVERY [%]	72
AIR VOLUME FLOW PER UNIT [m³/h]	10.5 – 29
EXHAUST AIR VOLUME FLOW PER UNIT [m³/h]	21 – 58
SOUND PRESSURE LEVEL [dB(A)], distance 2 m	12 – 37
STANDARD SOUND LEVEL DIFFERENCE $D_{n,e,w}$ [dB]	32
FLAIR INNER COVER DIMENSIONS [W x H, mm]	233 x 233
WEATHER PROTECTION HOOD DIMENSIONS [W x H, mm]	203 x 276

MINIMUM WALL THICKNESS [mm]	> 140
WALL OPENING DIAMETER [mm]	180
WALL MOUNTING SLEEVE DIAMETER [mm]	160
POWER CONSUMPTION [W]	1 – 3
VOLUME-FLOW-RELATED POWER CONSUMPTION [W/(m³/h)]	0.13
INGRESS PROTECTION	IP20
INPUT VOLTAGE [V DC]	6 – 16
ENERGY EFFICIENCY CLASS	A

Installation scheme iV-Compact

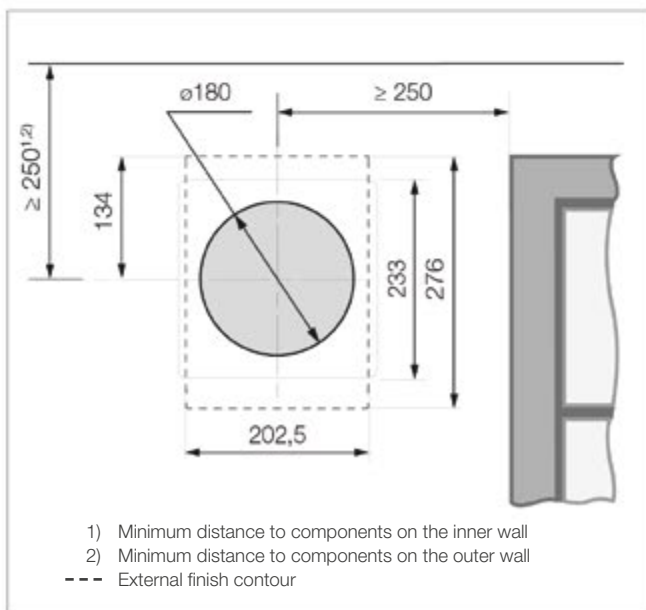
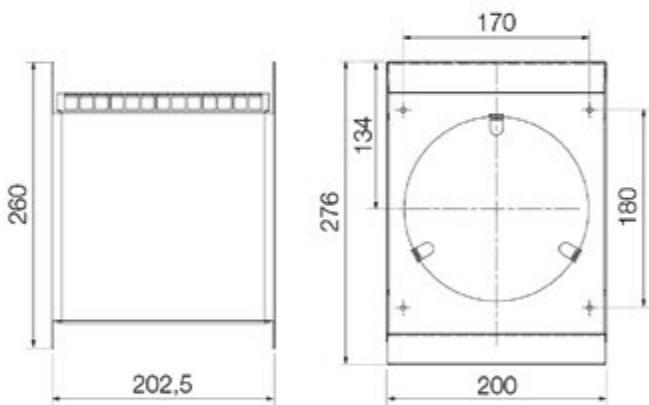
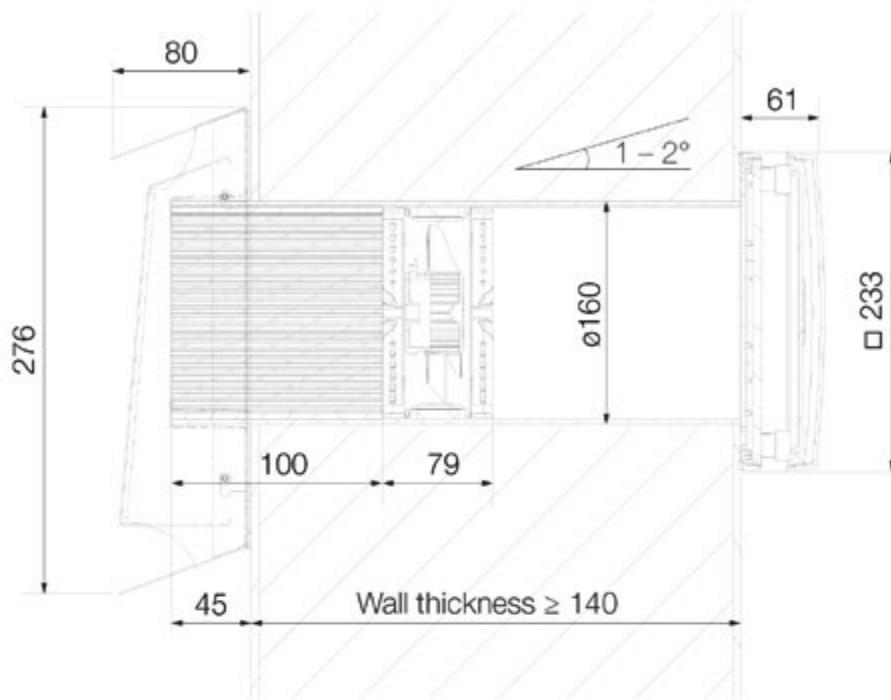

Remarks

To ensure that the system can be installed, observe the minimum clearances shown in the adjacent illustration. Minimum wall thickness: 140 mm.

Minimum distances from centre axis core bore

- to components on the inner wall/reveal: 250 mm circumferential
- to components on the outer wall 250 mm circumferential; mind lintels, reveal edges, insulation thickness, and any shutters.
- between two ventilation units in the same room: 1.2 m
- to other ventilation systems in the external area: 1.2 m
- Recommendation: Mount the upper edge of the weather protection hood at the height of the lower edge of the lintel (optics on the facade)
- Mount in the air volume flow of the room at approx. 1.80 m over the upper edge of the finished floor optimally.

All assembly and operating instructions as well as further information can be found at www.inventer.de.



DXF / DWG / STP

inVENTer iV-Office

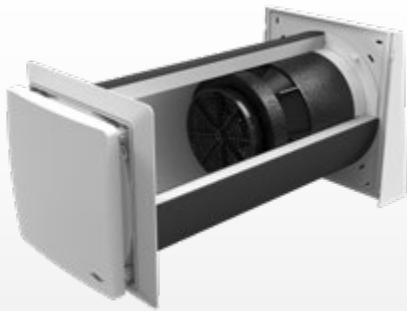

iV-Office complete system interior view

Decentralised ventilation system with heat recovery. Five-year manufacturer's warranty.

Enhanced-performance unit with sound insulation and increased air volume flow (up to 90 m³/h) for new construction and renovation. Complete system for easy integration into the outer wall. Patented inVENTron[®] technology: 88% heat recovery.

External control via controller.

Low operating costs thanks to low power consumption (5 W) and user maintenance capability.

Components

- Insert with ceramic honeycomb heat accumulator and Inventin[®] sound insulation insert
- inVENTron[®]: Xenion[®] EFP reversing fan with increased speed, temperature monitor, and wind pressure stabilizer, embedded in double air fin for flow rectification. Fan meets S2 classification according to DIN EN 13141-8
- Inner cover with G4 filter (ISO Coarse 60%), wall mounting sleeve, driving-rain-proof weather protection hood

Controller

- MZ-Home, sMove s4/s8

Accessories (optional)

- Pollen filter, activated carbon filter
- Sound and wind protection accessories
- Simplex R-D250

iV-Office external cover

Flex Office weather protection hood

White: RAL9016
Grey: RAL9006
Anthracite: RAL7016

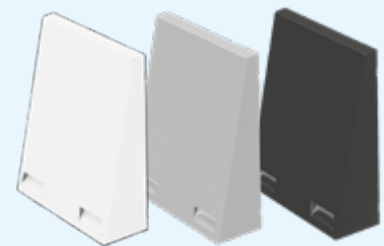

iV-Office internal cover

Flair XL inner cover (RAL9010)



Technical specifications

HEAT RECOVERY [%]	88
AIR VOLUME FLOW PER UNIT [m ³ /h]	10 – 45
EXHAUST AIR VOLUME FLOW PER UNIT [m ³ /h]	20 – 90
SOUND PRESSURE LEVEL [dB(A)], distance 2 m	12 – 37
STANDARD SOUND LEVEL DIFFERENCE D _{n,e,w} [dB]	49 – 55
FLAIR XL INNER COVER DIMENSIONS [W x H, mm]	280 x 280
WEATHER PROTECTION HOOD DIMENSIONS [W x H, mm]	279 x 313

MINIMUM WALL THICKNESS [mm]	260
WALL OPENING DIAMETER [mm]	270
WALL MOUNTING SLEEVE DIAMETER [mm]	250
POWER CONSUMPTION [W]	1 – 5
VOLUME-FLOW-RELATED POWER CONSUMPTION [W/(m ³ /h)]	0.14
INPUT VOLTAGE [V DC]	6 – 16
ENERGY EFFICIENCY CLASS	A+/A

Installation scheme iV-Office

► The installation scheme with IB Connect UP/AP can be found in the „inVENTer Connect controller platform“ subsection.

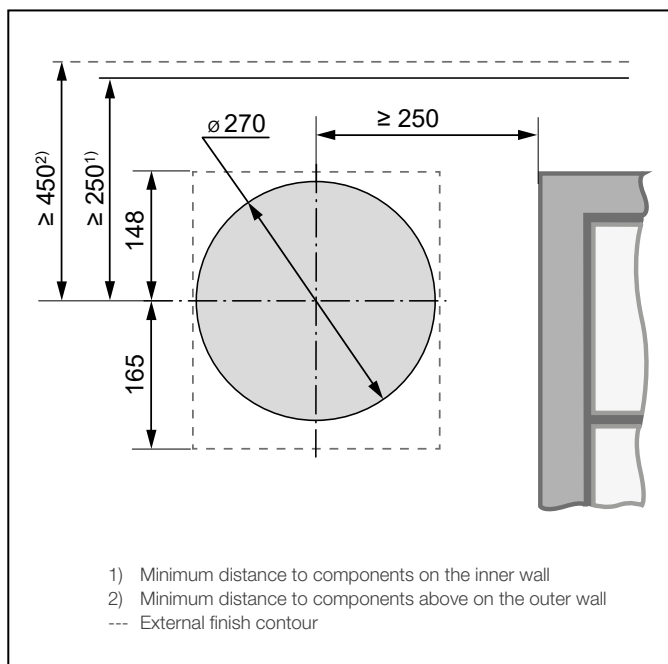
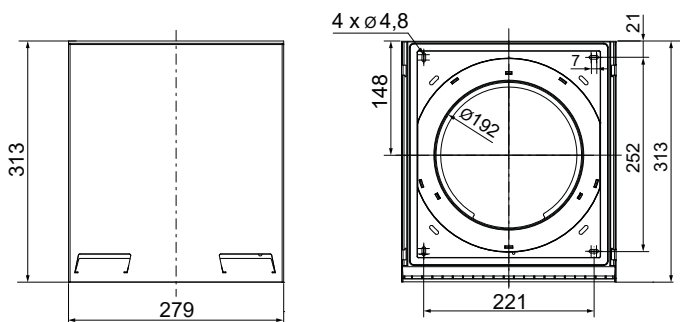
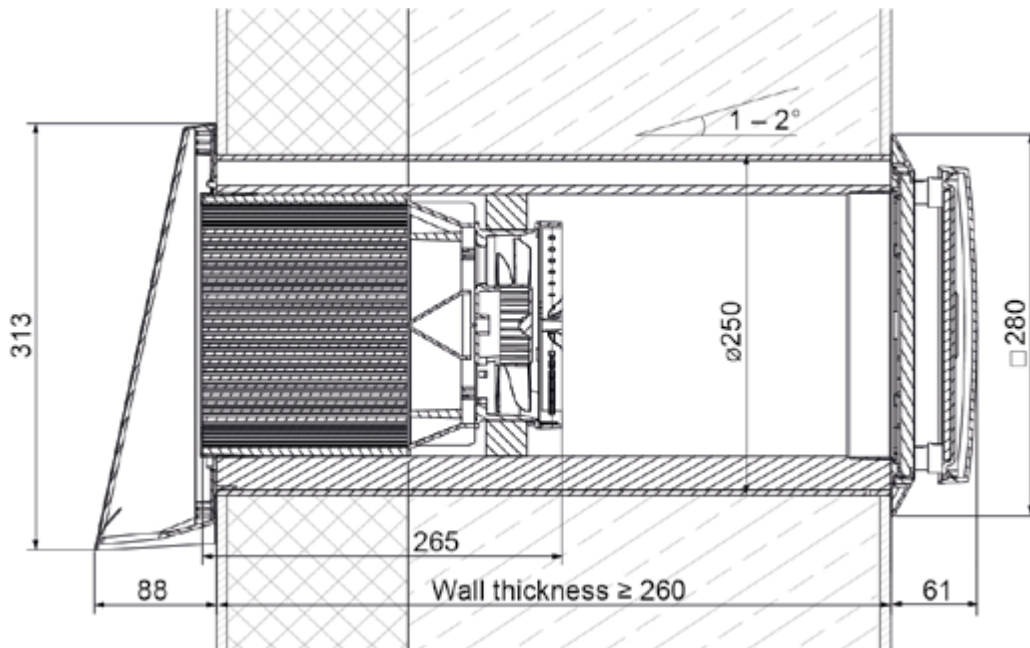

Remarks

To ensure that the system can be installed, observe the minimum clearances shown in the adjacent illustration.
 Minimum wall thickness: 260 mm.

Minimum distances from centre axis core bore

- to components on the inner wall/reveal: 250 mm circumferential
- to components on the outer wall 250 mm circumferential 250 mm (left, right, bottom) or 450 mm (top); mind lintels, reveal edges, insulation thickness, and any shutters
- between two ventilation units in the same room: 1.2 m
- to other ventilation systems in the external area: 1.2 m
- Recommendation: Mount the upper edge of the weather protection hood at the height of the lower edge of the lintel (optics on the facade)
- Mount in the air volume flow of the room at approx. 1.80 m over the upper edge of the finished floor optimally.

All assembly and operating instructions as well as further information can be found at www.inventer.de.



DXF / DWG / STP

inVENTer iV14-MaxAir



iV14-MaxAir complete system interior view

Decentralised ventilation system with heat recovery.

Five-year manufacturer's warranty.

Enhanced-performance unit with air volume flow of up to 90 m³/h for new construction and renovation. Complete system for easy integration into the outer wall. Quick installation with Simplex: Installation block with pre-installed wall installation sleeve, integrated slope. Patented inVENTron technology: 88% heat recovery.

External control via controller.

Low operating costs thanks to low power consumption (5 W) and user maintenance capability.

Components

- Insert with ceramic honeycomb heat accumulator
- inVENTron®: Xenion® EFP reversing fan with increased speed, temperature monitor, and wind pressure stabilizer, embedded in double air fin for flow rectification. Fan meets S2 classification according to DIN EN 13141-8
- Inner cover with G4 filter (ISO Coarse 60%), wall mounting sleeve, driving-rain-proof weather protection hood

Controller

- MZ-Home, sMove s4/s8

Accessories (optional)

- Pollen filter, activated carbon filter
- Sound and wind protection accessories
- Wall mounting block D230 or Simplex R-D200

iV14-MaxAir external cover
Flex weather protection hood

White: RAL9016
Grey: RAL9006
Anthracite: RAL7016

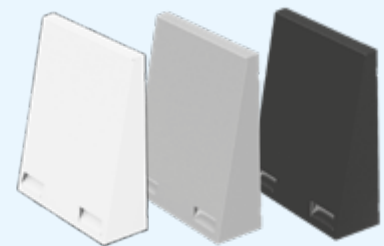

iV14-MaxAir internal cover
Flair inner cover
(RAL9010)



Technical specifications

HEAT RECOVERY [%]	88
AIR VOLUME FLOW PER UNIT [m ³ /h]	10 – 45
EXHAUST AIR VOLUME FLOW PER UNIT [m ³ /h]	20 – 90
SOUND PRESSURE LEVEL [dB(A)], distance 2 m	20 – 45
STANDARD SOUND LEVEL DIFFERENCE D _{n,e,w} [dB]	38 – 45
FLAIR INNER COVER DIMENSIONS [W x H, mm]	233 x 233
WEATHER PROTECTION HOOD DIMENSIONS [W x H, mm]	279 x 313

MINIMUM WALL THICKNESS [mm]	280
WALL OPENING DIAMETER [mm]	225
WALL MOUNTING SLEEVE DIAMETER [mm]	200
POWER CONSUMPTION [W]	1 – 5
VOLUME-FLOW-RELATED POWER CONSUMPTION [W/(m ³ /h)]	0.14
INPUT VOLTAGE [V DC]	6 – 16
ENERGY EFFICIENCY CLASS	A+/A

Installation scheme iV14-MaxAir

► The installation scheme with IB Connect UP/AP can be found in the „inVENTer Connect controller platform“ subsection.

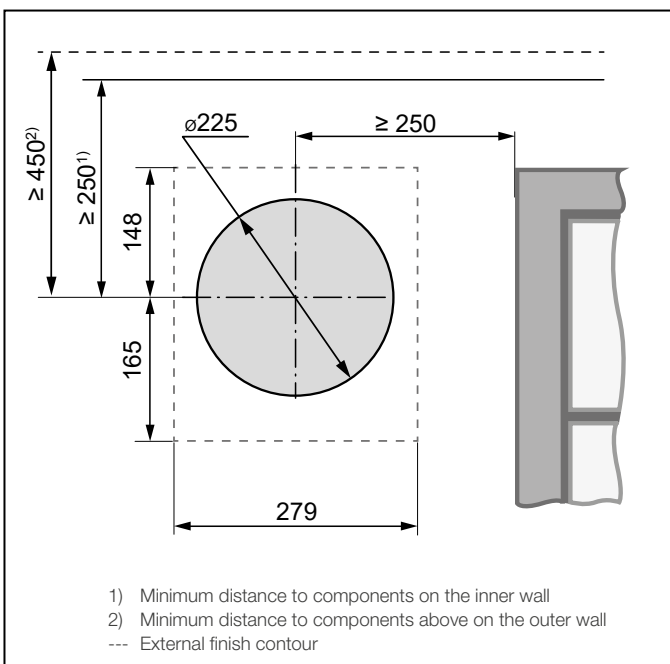
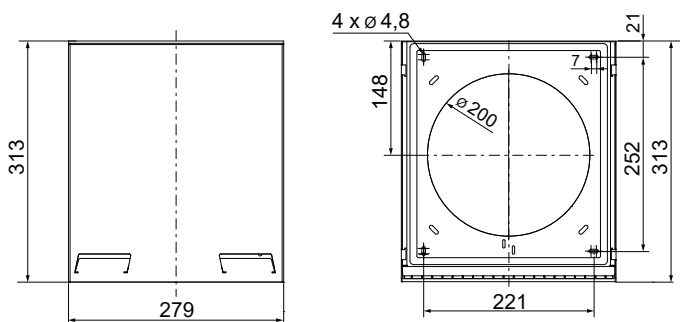
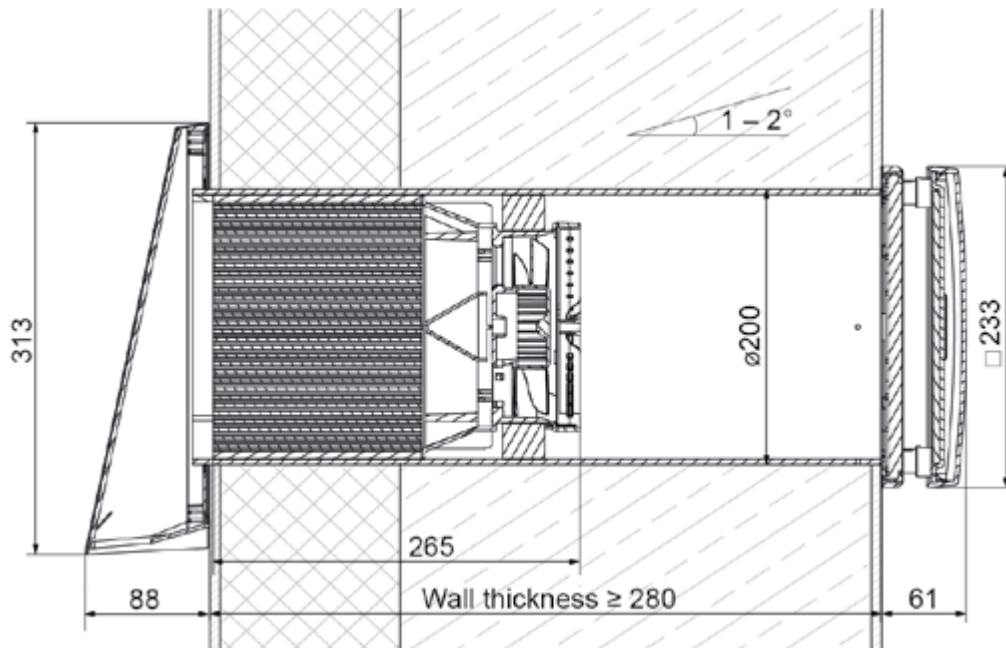

Remarks

To ensure that the system can be installed, observe the minimum clearances shown in the adjacent illustration.
 Minimum wall thickness: 280 mm.

Minimum distances from centre axis core bore

- to components on the inner wall/reveal: 250 mm circumferential
- to components on the outer wall 250 mm circumferential 250 mm (left, right, bottom) or 450 mm (top); mind lintels, reveal edges, insulation thickness, and any shutters
- between two ventilation units in the same room: 1.2 m
- to other ventilation systems in the external area: 1.2 m
- Recommendation: Mount the upper edge of the weather protection hood at the height of the lower edge of the lintel (optics on the facade)
- Mount in the room air volume flow at about 1.80 m above the upper edge of the finished floor

All assembly and operating instructions and further information can be found at www.inventer.eu.



DXF / DWG / STP

inVENTer iV14-MaxAir Corner

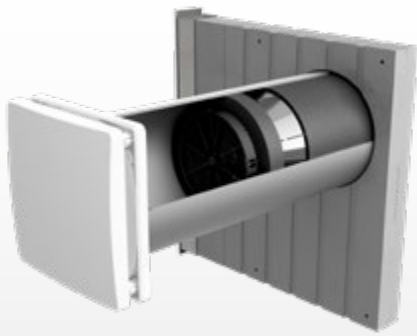

iV14-MaxAir Corner complete system interior view

Decentralised ventilation system with heat recovery.

Five-year manufacturer's warranty.

Enhanced-performance unit with air volume flow of up to 90 m³/h for new construction and renovation with concealed external finish for easy integration into outer walls with outer wall insulation. Quick installation with Simplex: Installation block with pre-installed wall installation sleeve, integrated slope. Patented inVENTron technology: 88% heat recovery. External control via controller.

Low operating costs thanks to low power consumption (5 W) and user maintenance capability.

Components

- Insert with ceramic honeycomb heat accumulator
- inVENTron®: Xenion® EFP reversing fan with increased speed, temperature monitor, and wind pressure stabilizer, embedded in double air fin for flow rectification. Fan meets S2 classification according to DIN EN 13141-8
- Inner cover with G4 filter (ISO Coarse 60%), wall mounting sleeve, Corner flat duct with integrated slope (including soffit grille)

Controller

- MZ-Home, sMove s4/s8

Accessories (optional)

- D200 substructure board
- Pollen filter, activated carbon filter
- Sound and wind protection accessories
- Wall mounting block D230 or Simplex R-D200

iV14-MaxAir Corner external cover
Soffit grille

White: RAL9016
Grey: RAL9006
Anthracite: RAL7016

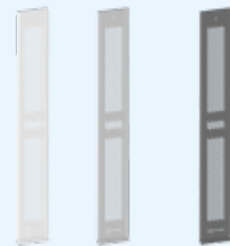

iV14-MaxAir Corner internal cover
Flair inner cover
(RAL9010)



Technical specifications

HEAT RECOVERY [%]	88
AIR VOLUME FLOW PER UNIT [m ³ /h]	10 – 45
EXHAUST AIR VOLUME FLOW PER UNIT [m ³ /h]	20 – 90
SOUND PRESSURE LEVEL [dB(A)], distance 2 m	20 – 45
FLAIR INNER COVER DIMENSIONS [W x H, mm]	233 x 233
SOFFIT GRILLE DIMENSIONS [W x H, mm]	70 x 527

MINIMUM WALL THICKNESS/INSULATION [mm]	280/> 70
WALL OPENING DIAMETER [mm]	225
WALL MOUNTING SLEEVE DIAMETER [mm]	200
POWER CONSUMPTION [W]	1 – 5
VOLUME-FLOW-RELATED POWER CONSUMPTION [W/(m ³ /h)]	0.14
INPUT VOLTAGE [V DC]	6 – 16
ENERGY EFFICIENCY CLASS	A+/A

Installation scheme iV14-MaxAir Corner

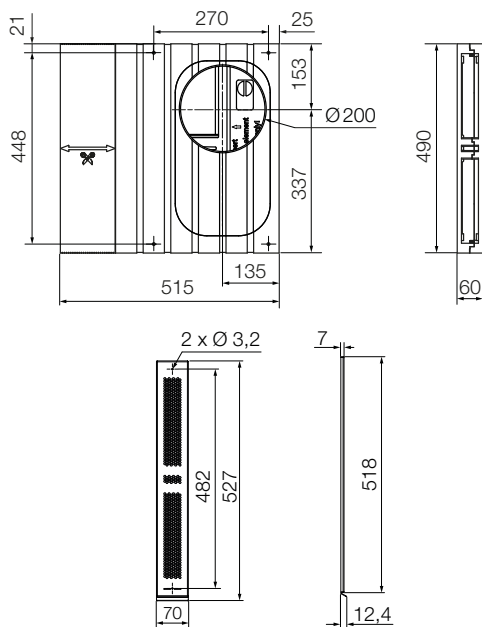
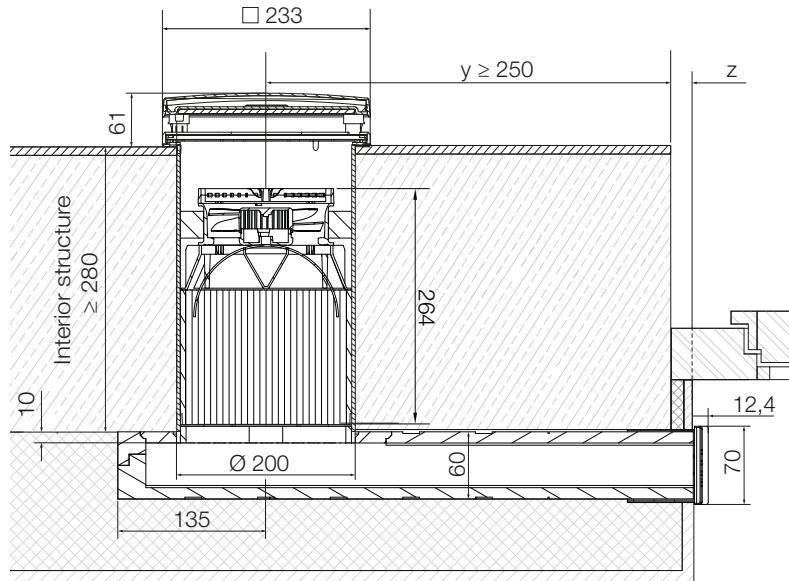

Remarks

To ensure that the system can be installed, observe the minimum clearances shown in the adjacent illustration. Minimum internal structure: 280 mm (masonry and interior structure/plaster). The flat duct can be underlaid with insulating material (such as the inVENTer UBP Corner substructure board).

- Minimum distances from centre axis core bore
- Insulation thickness on flat duct: > 10 mm
- to reveal (outside): 250 – 380 mm
- to components on the outer wall/intel: 200 mm;
- mind insulation thickness and any shutters
- between two ventilation units in the same room: 1.2 m
- to other ventilation systems in the external area: 1.2 m
- Installation length of the flat duct:
- $L = (y + z) + 135$, where $250 \leq (y+z) \leq 380$

All assembly and operating instructions and further information can be found at www.inventer.de.



DXF / DWG / STP

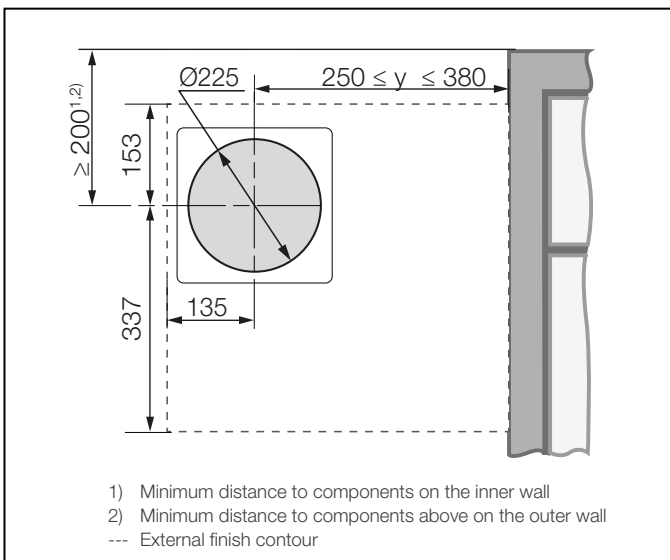

inVENTer iV14-MaxAir Nordic

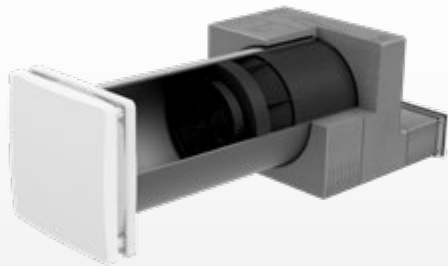

iV14-MaxAir Nordic complete system interior view

Decentralised ventilation system with heat recovery. Five-year manufacturer's warranty. Enhanced-performance unit with high air volume flow for new construction and renovation with external finish flush with the facade for easy integration into clinker facades or outer walls with insulation. Quick installation with Simplex: Installation block with pre-installed wall installation sleeve, integrated slope.

External control via controller.

Minimal operating costs thanks to low power consumption of 5 W and the possibility of user maintenance.

Components

- Insert with ceramic honeycomb heat accumulator
- inVENTron®: Xenion® EFP reversing fan with increased speed, temperature monitor, and wind pressure stabilizer, embedded in double air fin for flow rectification. Fan meets S2 classification according to DIN EN 13141-8
- Inner cover with G4 filter (ISO Coarse 60%), wall mounting sleeve
- Nordic facade end (including outer grille)

Controller

- MZ-Home, sMove s4/s8

Accessories (optional)

- Pollen filter, activated carbon filter
- D230 or Simplex R-D200 wall mounting block
- Soundproofing accessories

iV14-MaxAir Nordic external cover

Outer grille

White: RAL9016
 Grey: RAL9006
 Anthracite: RAL7016
 Copper brown: RAL8004

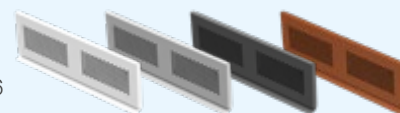

Internal cover
 iV14-MaxAir Nordic:
 Flair inner cover (RAL9010)



Technical specifications

HEAT RECOVERY [%]	88
AIR VOLUME FLOW PER UNIT [m³/h]	10 – 45
EXHAUST AIR VOLUME FLOW PER UNIT [m³/h]	20 – 90
SOUND PRESSURE LEVEL [dB(A)], distance 2 m	20 – 45
STANDARD SOUND LEVEL DIFFERENCE $D_{n,e,w}$ [dB]	46 – 53
FLAIR INNER COVER DIMENSIONS [W x H, mm]	233 x 233
OUTER GRILLE DIMENSIONS [W x H, mm]	280 x 86
WALL OPENING DIAMETER [mm]	225
WALL MOUNTING SLEEVE DIAMETER [mm]	200

MINIMUM WALL THICKNESS [mm]	250
+ INSULATION (INCL. GAP AS REQUIRED) [mm]	> 120
+ ANY CLINKER [mm]	115
TOTAL WALL. CLINKER / THERMAL INSULATION SYSTEM [mm]	> 475 / > 370
POWER CONSUMPTION [W]	1 – 5
VOLUME-FLOW-RELATED POWER CONSUMPTION [W/(m³/h)]	0.14
INGRESS PROTECTION	IP20
INPUT VOLTAGE [V DC]	6 – 16
ENERGY EFFICIENCY CLASS	A+ / A

Installation scheme for double-shell masonry with facing bricks (clinker)

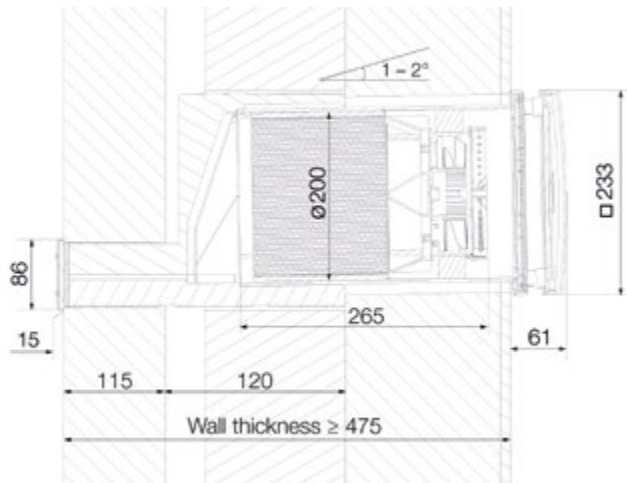

Installation scheme for single-shell masonry with thermal insulation system

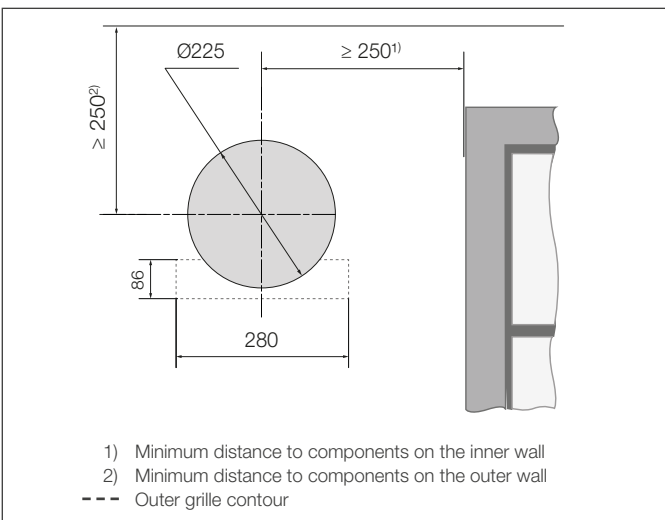
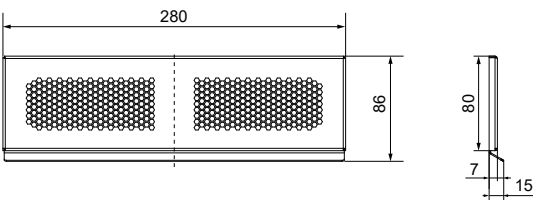
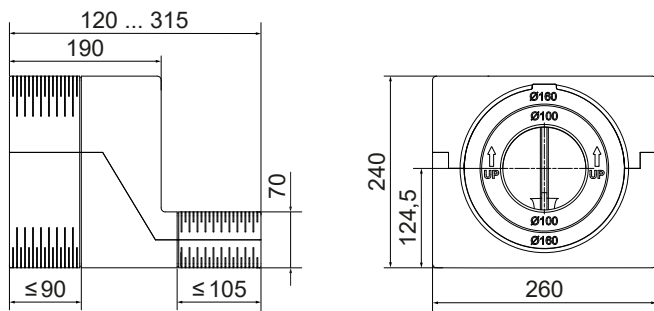
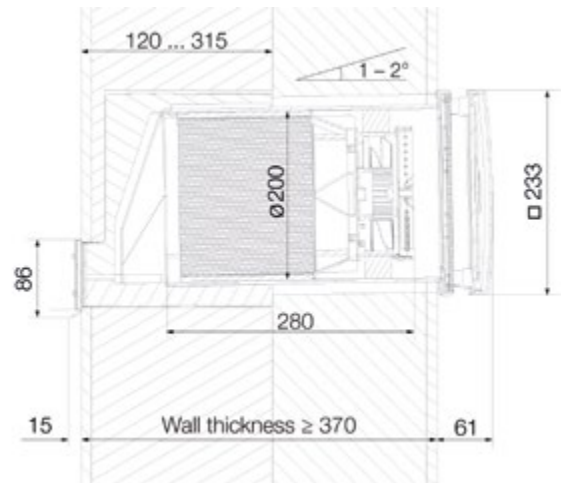

Remarks

When installing, observe the minimum distances in order to ensure that the system can be installed and functions properly.

Minimum overall wall thickness for clinker: 475 mm

Minimum overall wall thickness for thermal insulation system: 370 mm

Minimum insulation thickness including gap as required: 120 mm

Minimum distances from centre axis core bore

- to components on the inner wall/reveal: 250 mm circumferential
- to components on the outer wall 250 mm circumferential; mind lintels, reveal edges, insulation thickness, and any shutters
- between two ventilation units in the same room: 1.2 m
- to other ventilation systems in the external area: 1.2 m
- Mount in the room air volume flow at about 1.80 m above the upper edge of the finished floor

All assembly and operating instructions and further information can be found at www.inventer.de.



DXF / DWG / STP

inVENTer PAX



Centralised residential ventilation system for increased sound insulation; with heat recovery and automatic humidity monitoring. Five-year manufacturer's warranty. Suitable for new construction and renovation.

Installation in exhaust air rooms with moisture ingress. Connection directly to external wall or optionally via piping for ventilation of internal rooms with heat recovery. Can be installed in false ceilings. Complete device for ventilating micro-apartments.

Integrated preheating radiator and cross-flow heat exchanger. Can be operated directly on the device or with a remote control. Air volume flow is automatically calibrated during commissioning. Operating modes: Normal, Summer, Eco, and Comfort.

Basic component set

- Main module including radial fan, G4 filter system (ISO Coarse), radiator, cross-flow heat exchanger, and control unit
- Insulated wall duct, flat weather protection hood
- Infrared remote control
- Silencer
- Connector

Accessories (optional)

- Spiral duct, L 995 mm
- Supply air poppet valve
- Silencer
- Nipple-and-bushing connector
- 90° bend including lip seal
- T-piece including lip seal
- Pipe end cover
- Pipe system
- Fastening clip
- Dust filter set



Technical specifications

HEAT RECOVERY [%]	Ø 77, max. 80
WRG AIR VOLUME FLOW [m³/h]	30 – 78
EXHAUST AIR VOLUME FLOW [m³/h]	90
WRG SOUND PRESSURE LEVEL [dB(A)]	19 – 29
EXHAUST AIR SOUND PRESSURE LEVEL [dB(A)]	35
EXHAUST AIR SPACE STANDARD SOUND LEVEL DIFFERENCE [dB]	47
SUPPLY AIR SPACE STANDARD SOUND LEVEL DIFFERENCE [dB]	77
HORIZONTAL WEATHER PROTECTION HOOD [W x H x D, mm]	393 x 212 x 52
VERTICAL WEATHER PROTECTION HOOD [W x H x D, mm]	203 x 389 x 66

MAIN MODULE DIMENSIONS [W x H x D, mm]	720x340x191
WALL OPENING DIAMETER [mm]	2 x 160
POWER CONSUMPTION [W]	3.5 – 25
ELECTRICAL PREHEATING RADIATOR [W]	max. 375
PROTECTION CLASS	II
INGRESS PROTECTION	IP24
MAINS VOLTAGE [V AC], [Hz]	230, 50
ENERGY EFFICIENCY CLASS	A

inVENTer PAX functionality



Airflows at the PAX main module



Air volume flow/pressure curve

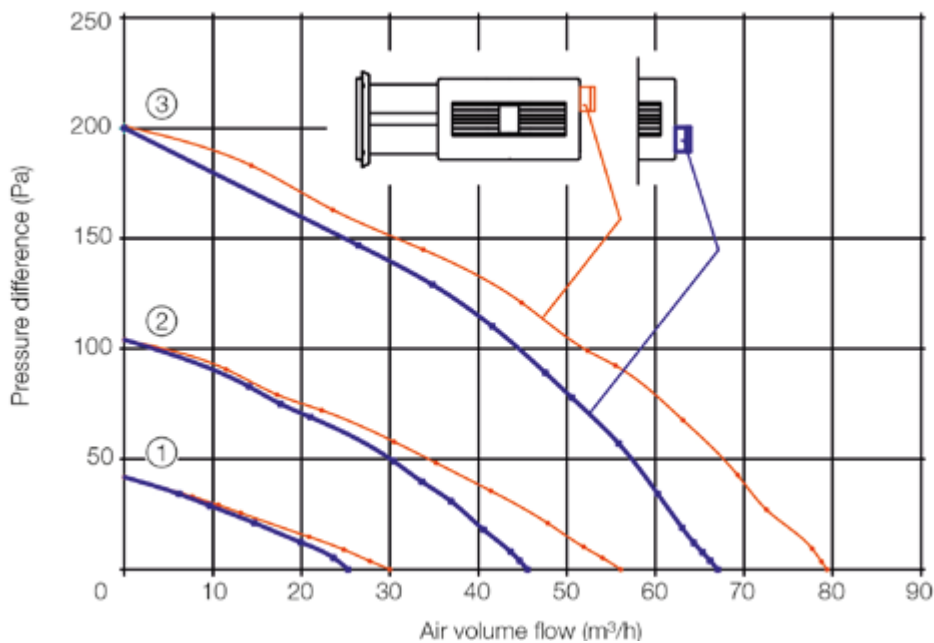

Installation with roof outlet

- Always install the ventilation unit horizontally.
- Minimum distance to adjacent components in the interior: 85 mm.
- The roof hood must be installed above the normal local snow depths and in a driving-rain-proof manner. Minimum distance between two outer hoods/to other ventilation components in the exterior space: 1.2 m
- External and exhaust air lines must have impermeable insulation.
- Consider options for draining condensate in the external and exhaust lines.
- Wall mounting sleeves located in unheated areas must be insulated at the appropriate points.

Installation scheme inVENTer PAX

Schematic installation position: horizontal in false ceiling, side view

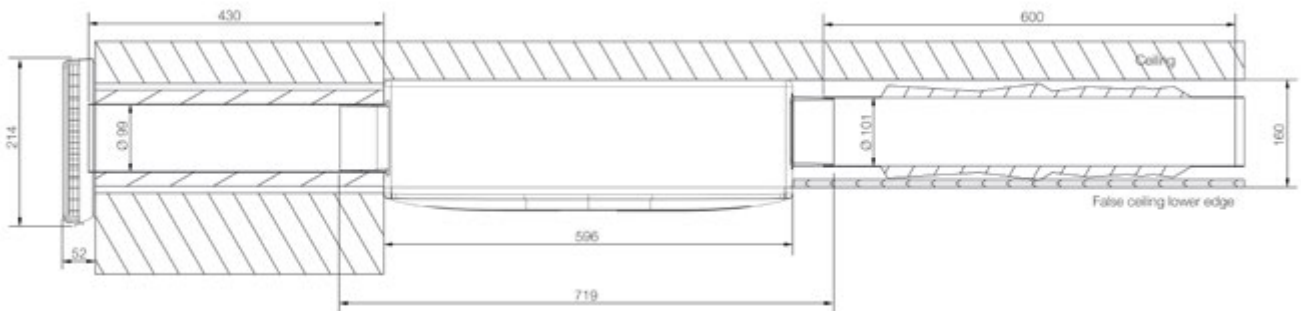

Schematic mounting position: Installation in ceiling, view from below

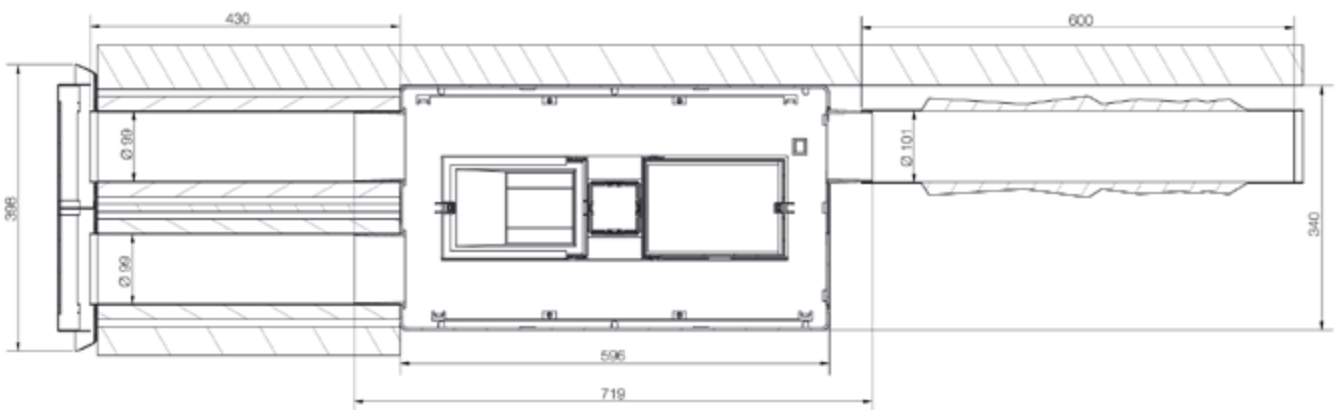

Outer wall opening schematic for horizontal installation

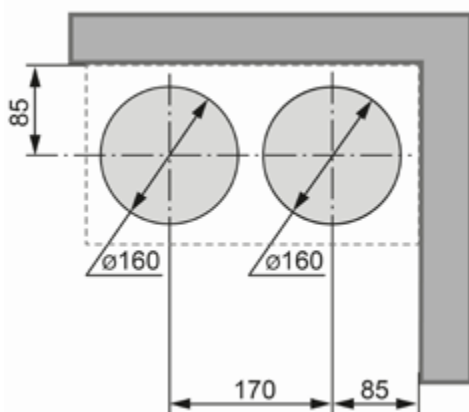

Remarks

- Minimum clearance between two outer hoods and other ventilation components in the outside area: 1.2 m
- Minimum clearance to adjacent components: 250 mm
- Observe sound decoupling: Pipe systems and wall ducts must be designed with structure-borne sound insulation in mind (use a silencer downstream of the unit and between two rooms).
- Mount on a firm, level and permanently load-bearing surface.
- Connection with permanent wiring.
- Make sure that there is enough space to open the front panel, and ensure a visual view of the front panel.
- Connect each ventilation unit to its own outdoor and exhaust air connection.
- Maximum length of the pipe system: 10 m

All assembly and operating instructions as well as further information can be found at www.inventer.de.



DXF / DWG / STP



X-Flow

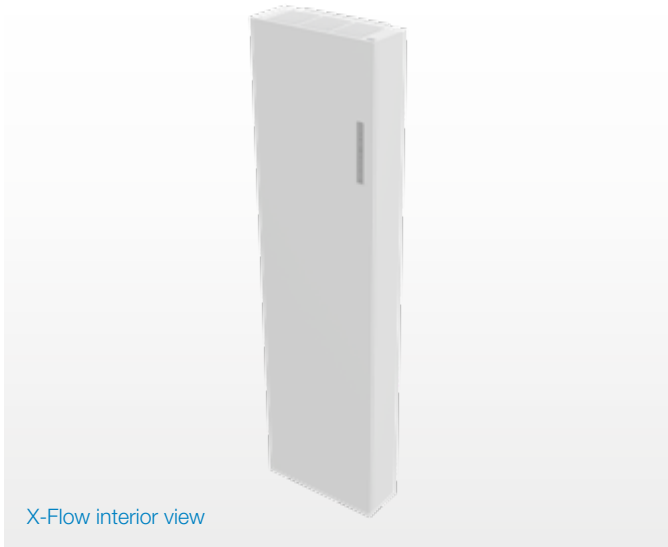

Decentralised single-room unit with heat recovery and integrated CO₂, temperature, and humidity sensor. Suitable for new construction and renovation.

Can be installed in residential or commercial spaces. Connection directly to outer wall for internal room ventilation. Direct connection to a 230 V outlet.

Controlled with a touchpad directly on the device.

Automatic operation based on measured CO₂ values indoors. Other operating modes: Manual, boost, pause.

Components

- Main module with cross-flow heat exchanger
- Indoor and outdoor air filter
- Integrated sensors: CO₂ sensor, temperature and humidity sensor
- Touchpad
- Pre-installed connection cable

Accessories

Installing X-Flow requires a wall duct with a suitable external cover.

For these solutions, inVENTer offers the following:

- R-D160 wall mounting sleeve
- Light weather protection grille (RAL 9010)



Technical specifications

HEAT RECOVERY [%]	87
AIR VOLUME FLOW [m ³ /h]	50 – 180
SOUND PRESSURE LEVEL [dB(A)], 2 m	12 – 32
POWER CONSUMPTION (MAX.) [W]	33.4
MAINS VOLTAGE [V AC, Hz]	230, 50
SPECIFIC INPUT POWER [W/(m ³ /h)]	0.15
STANDBY CONSUMPTION [W]	< 1
FILTER	ePM 10-70%
WEIGHT [kg]	40

DIMENSIONS [W x H x D, mm]	520x1945x202
WALL OPENING DIAMETER [mm]	2 x 180
WALL MOUNTING SLEEVE DIAMETER [mm]	2 x 160
USE IN BUILDINGS [m]	Up to 80
FLAPS	Close automatically for supply and exhaust air
SENSORS	CO ₂ , temperature, humidity
PROTECTION CLASS	I
ENERGY EFFICIENCY CLASS	A

Installation scheme X-Flow

Example: rear air outlets

Can be installed in the left and right corners and in the centre

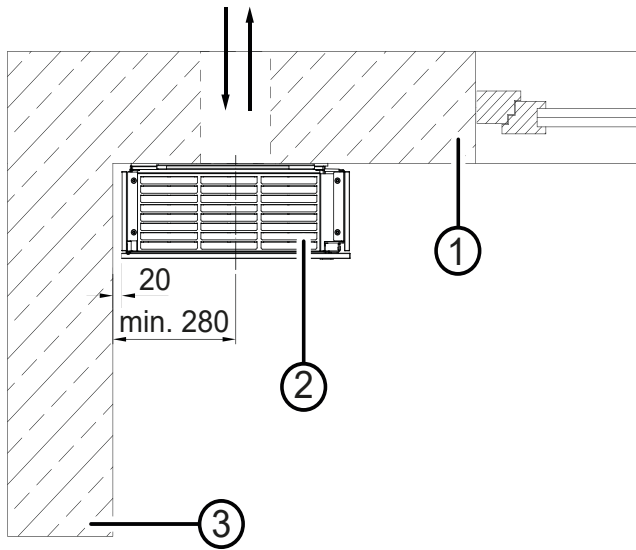

- 1 Outer wall
- 2 X-Flow
- 3 Wall

Example: lateral air outlets

Can be installed in the left and right corners

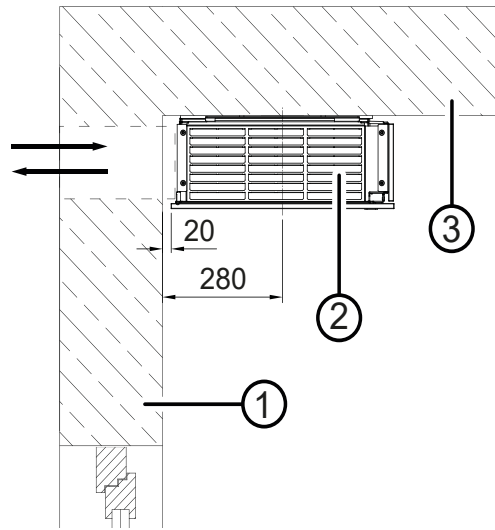

- 1 Outer wall
- 2 X-Flow
- 3 Wall

Outer wall opening schematic, rear air outlets

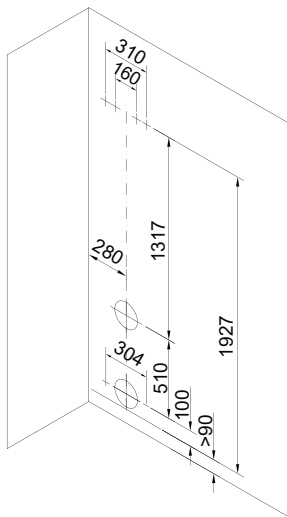

Outer wall opening schematic, lateral air outlets

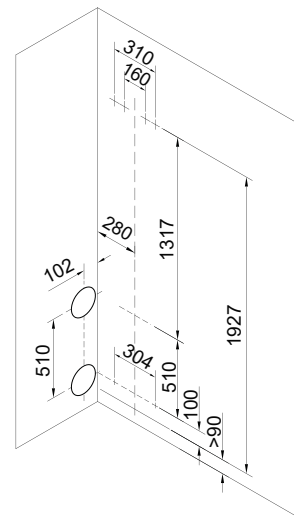

Remarks

To ensure that the system can be installed, observe the minimum clearances in the illustration above.

Minimum distances from the core bore centre axis to components on the inner wall/reveal: 280 mm circumferential.

All assembly and operating instructions and further information can be found at www.inventer.de.



DXF / DWG / STP

Overflow System USTS 100 Pulsar

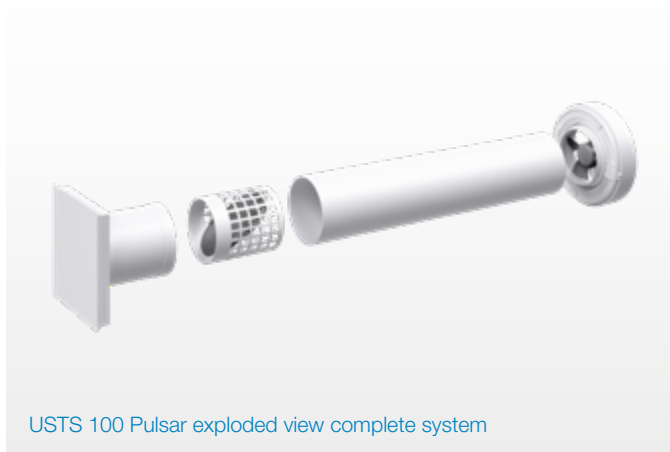

Ventilation system for active ventilation support from room to room for integration into interior walls.

Five-year manufacturer's warranty.

Programming and control via Bluetooth with the inVENTer Mobile app.

Not suitable for ventilating interior sanitary rooms according to DIN 18017-3. Meets the mechanical safety requirements of 60335-8-20.

Minimal operating costs thanks to low power consumption and the possibility of user maintenance.

The USTS 100 Pulsar operates without heat recovery.

Cascade ventilation can be implemented in conjunction with the IV ventilation systems.

Components

- Multi-functional overflow fan
- Wall mounting sleeve
- Internal panel
- Filter cartridge with G1 dust filter (ISO Coarse)

Operation modes

- Continuous ventilation
- Sensor-controlled (light sensor)
- Interval operation
- Overflow based on defined temperature limit value

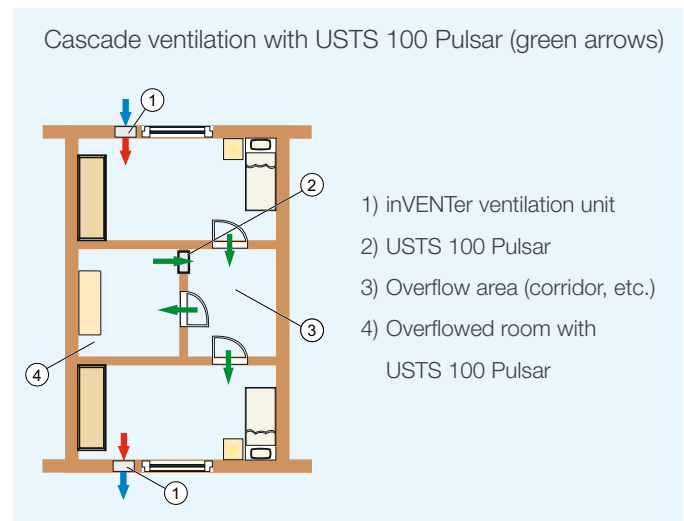

Overflow air volume flow rate $q_{v, \ddot{U}LD}$ [m ³ /h]	10	20	30	40	50	60	70	80	90	100		
Doors with grommets (laterally and top)	Free minimum area		25	50	75	100	125	150	175	200	225	250
Doors without grommet	$A_{\ddot{U}LD}$ in cm ²		0	25	50	75	100	125	150	175	200	225

Technical specifications

MINIMUM WALL THICKNESS [mm]	120
WALL OPENING DIAMETER [mm]	115
AIR VOLUME FLOW IN CONTINUOUS OPERATION [m ³ /h]	30
POWER CONSUMPTION [W]	4
OPERATING VOLTAGE [V AC], [Hz]	230, 50
ALTERNATIVE OPERATING VOLTAGE [V DC]	12
SOUND EMISSION [dB(A)]	17 – 20
INGRESS PROTECTION	IP44
PROTECTION CLASS	II
DUST FILTER CLASS	G1

Download inVENTer Mobile app:



You can find detailed information about the requirements for the operating system in the stores and on www.inventer.de

Installation scheme Overflow system USTS Pulsar

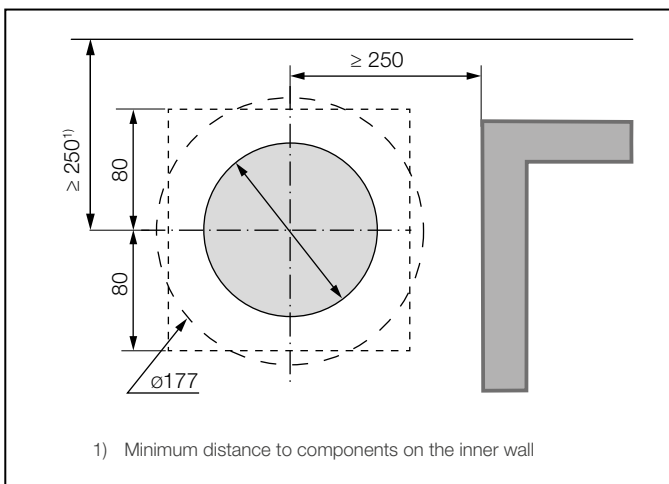
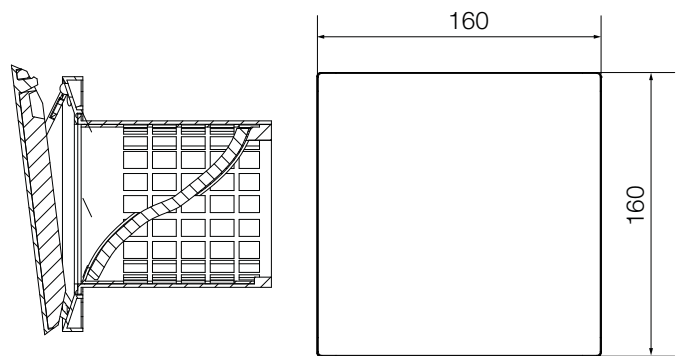
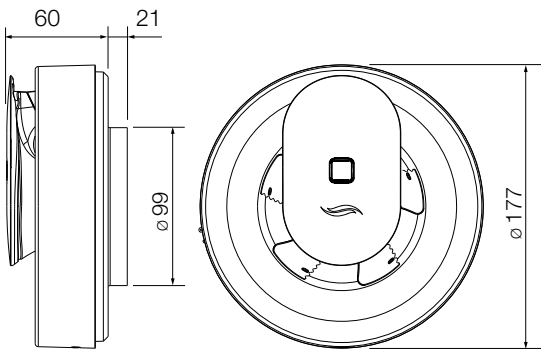
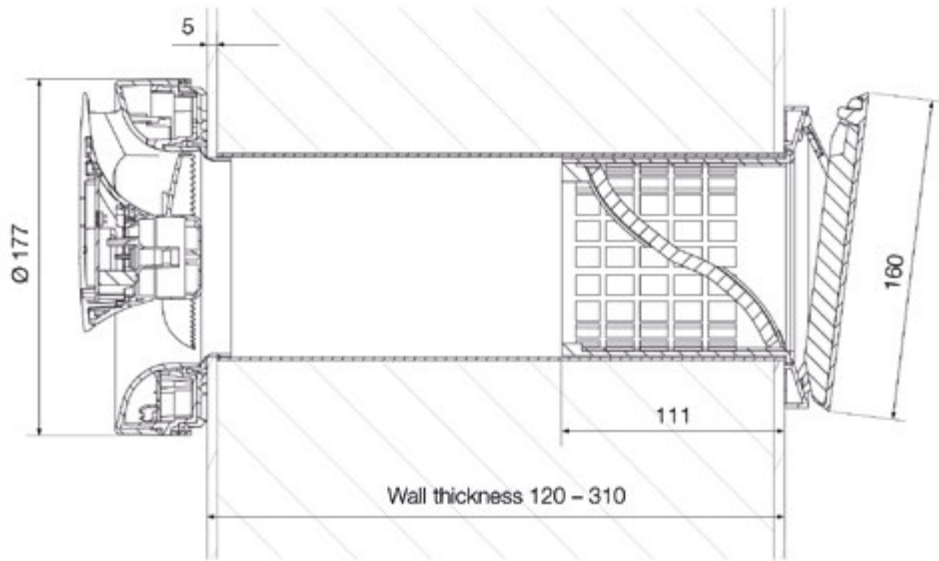

Remarks

To ensure that the system can be installed, observe the minimum clearances shown in the adjacent illustration.
Minimum wall thickness: 120 mm.

Minimum distances from centre axis core bore

- to components on the inner wall/reveal: 250 mm circumferential
- Mount in the air volume flow of the room at approx. 1.80 m over the upper edge of the finished floor optimally.

All assembly and operating instructions as well as further information can be found at www.inventer.de.



DXF / DWG / STP

Controller

for inVENTer ventilation systems



sMove controller



sMove controller, RAL9016

Controller for controlling the inVENTer ventilation units.
Five-year manufacturer's warranty.

Simultaneous operation and display interface through integrated illuminated displays. Simple switching between operating modes via capacitive buttons.

Air volume flow adjustable in four pre-defined ventilation modes or infinitely variable control via slider controller. Can also be switched off completely (standard version only). Flat version: Deactivation lock. Operating hours counter available for all variants.

Number of controllable ventilation units

sMove s4: 4x iV-Smart+, iV14-Zero, iV-Light, iV-Compact
2x iV-Twin+, iV-Office, iV14-MaxAir

sMove s8: 8x iV-Smart+, iV14-Zero, iV-Light, iV-Compact
4x iV-Twin+, iV-Office, iV14-MaxAir

Functions

- Operating modes: Heat recovery, ventilation, and pause/stop
- Boost function: 15 minutes
- Pause function: 1, 2, 4, or 8 hours

Features

- Switching power supply included (flush-mounted/control cabinet version)
- Sensors can be added to the controller
- External interface allows connection of a voltage-free switching contact (which defines ventilation system behaviour when the connected sensor is activated – ventilation or deactivation of all connected ventilation units)
- Analogue input allows integration into any existing home automation system

Accessories (optional)

- CS1 CO₂ sensor
- Hygrostat HYG18 / Hygrostat HYG12
- Flush-mounted socket 60x66
- Flush-mounted socket 60x90
- Socket dry wall 68x61
- Socket wall mounted 70x87
- Round cable LiYY-O 3x0,75 (33m)

Technical specifications

MAINS VOLTAGE [V AC], [Hz]	230, 50
OPERATING VOLTAGE [V DC]	24
POWER CONSUMPTION IN STANDBY [W]	< 1
POWER CONSUMPTION (MAX.) [W]	sMove s4: 10 sMove s8: 20
EXTERNAL SWITCHING CONTACT (OPTIONAL)	
SMOKE EXHAUST MONITOR	NC contact
OTHER SENSORS	NO contact
INGRESS PROTECTION	IP20
PROTECTION CLASS	II
CONTROL UNIT DIMENSIONS [W x H x D, mm]	86 x 86 x 24

Example: Star-shaped connection of ventilation units

(sMove s8 with control cabinet switching power supply)

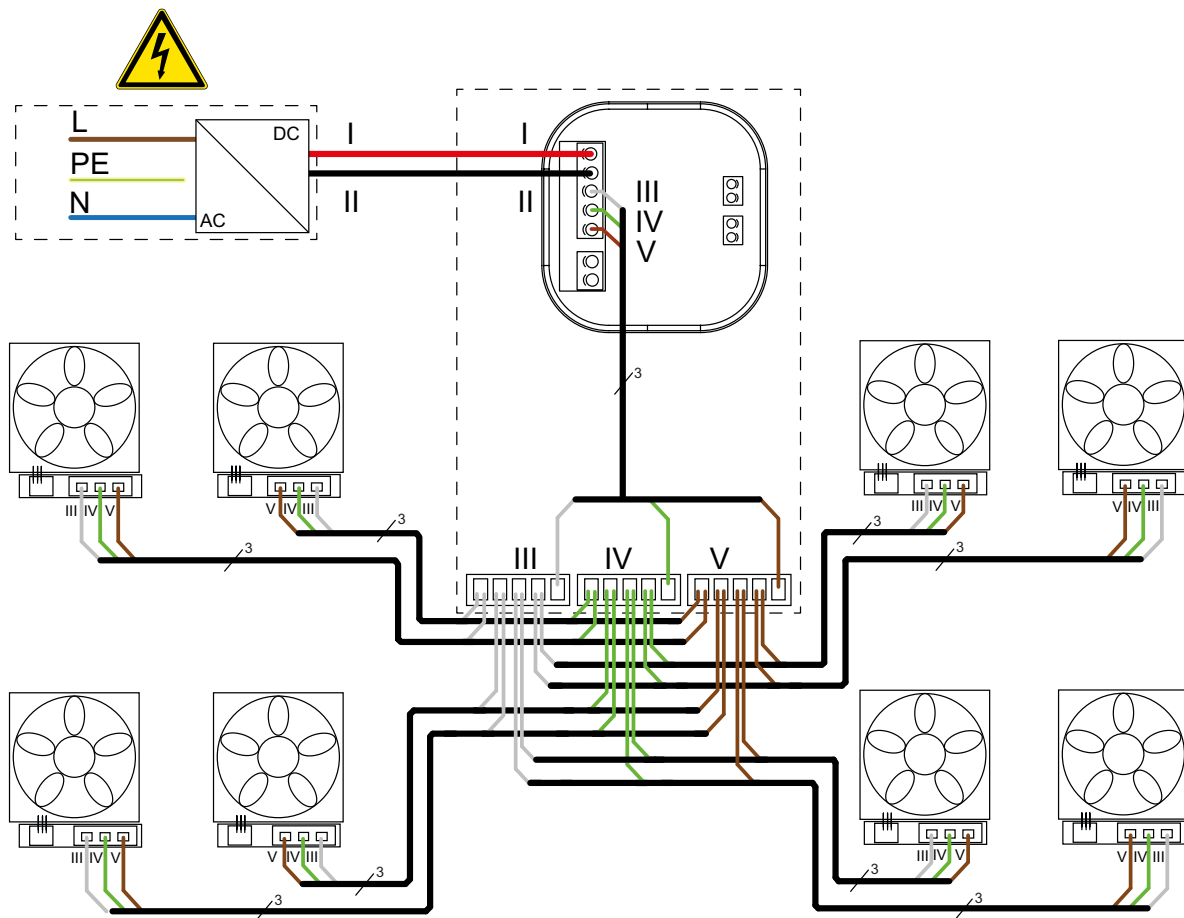

Maximum cable lengths

Operating voltage cable between power supply unit and controller: max. 100 m

sMove s4/star-shaped connection

Between controller and iV-Smart+ / iV14-Zero / iV-Light / iV-Compact max. 33 m

Between controller and iV14-MaxAir/iV-Office/iV-Twin+ max. 25 m

sMove s4/connection in series/between controller and last ventilation unit

Controller with 4 x iV-Smart+ / iV14-Zero / iV-Light / iV-Compact max. 15 m

Controller with 2 x iV-Smart+ / iV14-Zero / iV-Light / iV-Compact max. 25 m

Controller with 2 x iV14-MaxAir/iV-Office/iV-Twin+ max. 15 m

sMove s8/star-shaped connection

Between controller and iV-Smart+ / iV14-Zero / iV-Light / iV-Compact max. 33 m

Between controller and iV14-MaxAir/iV-Office/iV-Twin+ max. 20 m

sMove s8/connection in series/between controller and last ventilation unit

Controller with 8 x iV-Smart+ / iV14-Zero / iV-Light / iV-Compact max. 10 m

Controller with 2 x iV-Smart+ / iV14-Zero / iV-Light / iV-Compact max. 20 m

Controller with 2 x iV14-MaxAir/iV-Office/iV-Twin+ max. 10 m

inVENTer Connect controller platform

The inVENTer Connect controller platform is an innovative control system for the decentralised inVENTer iV ventilation units with heat recovery. It allows the individual devices in a system to be integrated into an 868 MHz radio network and controlled and programmed wirelessly. Depending on structural and individual requirements, the platform can be set up with the components described below.

Component description



Easy Connect e16 controller (obligatory)

Central hub for the inVENTer Connect radio network.

The radio control unit has an info display and can be used for quick access. The controller also serves as an access point for the inVENTer Mobile app (Bluetooth interface, BLE).



Connect inner cover (obligatory)

Radio inner cover. The Connect inner cover replaces the standard inner covers of the iV-Smart+, iV14-Zero, iV-Compact, and iV-Light ventilation units, allowing integration into the radio network.

In addition to the radio interface, the Connect inner cover has local control electronics, a power supply unit, and an automatic closure flap.



inVENTer Mobile app (obligatory for programming)

Free inVENTer app for Android and iOS for controlling and programming the Connect system.

The ventilation system can be started up without the app. Rudimentary controls are available with the radio controller. A more in-depth set-up and full access to functionality requires a mobile terminal device on which the inVENTer Mobile app is installed.

Download app
inVENTer Mobile:



You can find detailed information about the requirements for the operating system in the stores and on www.inventer.de

Sensors (optional)



FTS19-Connect humidity/temperature sensor, indoor: Radio sensor for monitoring humidity values within a ventilation zone.



FTS19-Connect humidity/temperature sensor, outdoor: Outdoor radio sensor for communicating outdoor temperature to the system.



CS2-Connect CO₂ sensor: Radio sensor for monitoring CO₂ and humidity values within a ventilation zone.



SK19-Connect switching contact: Radio interface for integrating safety devices when the ventilation system is operated at the same time as fireplaces.

Implementation

Within the usage unit, the **Easy Connect e16 controller** is installed in a position that is as central as possible, from which it sends control commands through the Connect inner covers to the ventilation units, while sensors send data to the controller.



1. The controller system consists of the Connect inner cover, the Easy Connect e16 controller, and the inVENTer Mobile smartphone app.
2. For implementation, the iV14-Zero, iV-Smart+, iV-Light and iV-Compact ventilation units are integrated into the outer walls and fitted with the Connect inner cover instead of the standard Flair/Flair SDE or Light inner cover (housing installation necessary).
3. Power supply: 230V mains voltage to the individual Connect inner covers. It is not necessary to wire the individual devices to each other!
4. Install the Easy Connect e16 controller as the control unit in the usage unit. Power supply: 230V mains voltage.
5. Optional: Equip ventilation zones with sensors. The humidity/temperature sensor is battery-powered and can be placed at any location.
6. Commissioning with the inVENTer Mobile app (Android/iOS). Define ventilation zones from the individual devices and sensors.
7. Assign the relevant ventilation profiles to the individual ventilation zones.

Remarks

- The flush-mounted variant of the Connect inner cover is almost flush with the wall.
- inVENTer Connect has its own 868 MHz network. This rules out interference with local WiFi networks. No WiFi network is necessary!
- The Easy Connect e16 controller can manage 16 devices/sensors in up to four ventilation zones.
- All sensors are optional, but an outdoor humidity/temperature sensor is required for full functionality (summer operation, for instance).
- In work rooms and common rooms, CO₂ monitoring is useful; alternatively, the CO₂ value can also be measured in the overflow area (mixed air value).
- Communication between the smartphone app and the Easy Connect e16 controller is via Bluetooth. During operation, basic functions can also be controlled directly via the Easy Connect e16 controller's keys.

Controller Easy Connect e16



Easy Connect e16 controller, RAL9016

Wireless controller for controlling and programming up to 16 Connect inner covers (iV-Smart+, iV14-Zero, iV-Light, iV-Compact) or radio sensors in up to four different ventilation zones.

Integrated humidity/temperature sensor for Ventilation Zone 1.

Five-year manufacturer's warranty.

Components

- Control unit with display, mounting plate, and power supply unit.
- 868 MHz radio technology for communication with up to 16 Connect inner covers or radio sensors.
- Bluetooth module for access via app "inVENTer Mobile" (Android / iOS).
- Interface for RS485 data cable as an alternative to the radio version.
- Humidity/temperature sensor integrated.

Accessories (optional)

- Humidity/temperature sensor FTS19-Connect indoor
- Humidity/temperature sensor FTS19-Connect outdoor
- CO₂-Sensor CS2-Connect
- SK19-Connect switching contact

Features

Automatic control of individual ventilation zones according to selected ventilation profiles

Demand-driven ventilation via room humidity and via carbon dioxide values, outside temperature and dew point control, if appropriate sensors are used.

Display with indication of air volume flow, ventilation modes, ventilation profiles, indoor humidity/temperature values, outdoor temperature value, indoor air quality, time, system messages, system warnings.

Technical specifications

CONTROL UNIT DIMENSIONS [W x H x D, mm]	90 x 90 x 15
RADIO FREQUENCY [MHz]	868
RADIO NETWORK RANGE [m]	Open field: 100 Building: 20
MAINS VOLTAGE [V AC], [Hz]	230, 50
OPERATING VOLTAGE [V DC]	5
POWER CONSUMPTION (MAX.) [W]	0.6
HUMIDITY MEASUREMENT RANGE [% rF]	20 – 90
TEMPERATURE MEASUREMENT RANGE [°C]	0 – 60
INGRESS PROTECTION	IPX2
PROTECTION CLASS	II

Set-up and management of:

- Coupled devices/sensors
- Individual ventilation zones
- Limit values for humidity/CO₂
- Direction of fan rotation
- System updates
- Ventilation profiles
- Boost and pause settings
- Filter replacement intervals
- Maintenance intervals
- System resets

Fast access via keypad.

Connection of and communication between Controller and inner cover Connect

Controller Easy Connect e16 wireless solution

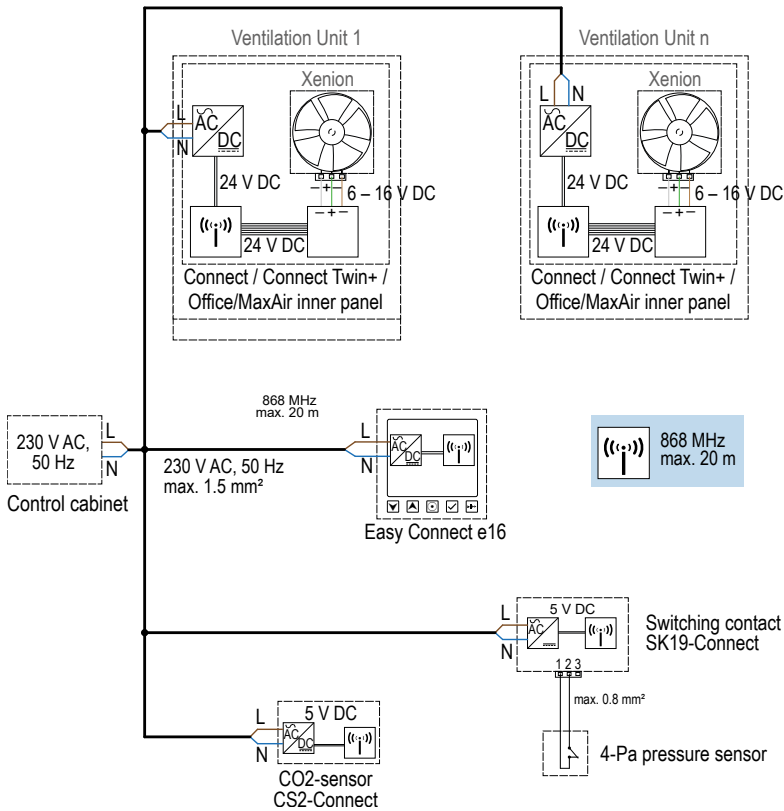

NOTICE: The Easy Connect e16 should be placed centrally in the usage unit. The maximum range from the controller to all components is 20 m.

Controller

Easy Connect e16 controller cable variant (alternative)

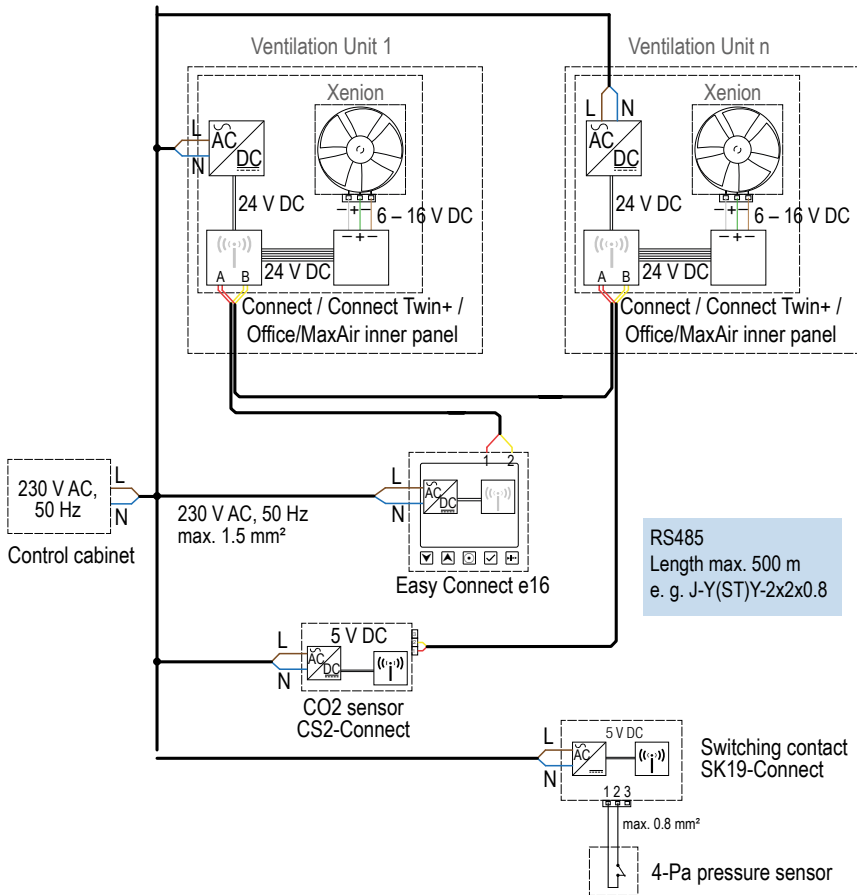

Controller Basic Connect e4/e8



Controller Basic Connect, white, RAL9016



Controller Basic Connect, black, RAL9005

Wireless controller for controlling and programming up to:

- Basic Connect e4: 4 inner covers Connect / inner covers Connect Twin+ / inner covers Connect Office/MaxAir + 2 sensors
- Basic Connect e8: 8 inner covers Connect / inner covers Connect Twin+ / inner covers Connect Office/MaxAir + 2 sensors

5-year manufacturer's guarantee.

Components

- Control unit with keypad, mounting plate and power supply unit.
- 868 MHz radio technology for communication with up to 8 Connect inner covers + 2 sensors.
- Interface for RS485 data cable as an alternative to the radio version.

Accessories (optional)

- Humidity/temperature sensor FTS19-Connect Indoor
- CO₂ sensor CS2-Connect
- Switch contact SK19-Connect

Equipment

Control unit with keypad: Display of air volume flow, ventilation modes, system warnings.

Demand-controlled ventilation via room air humidity and, if appropriate sensors are used, via carbon dioxide values.

Technical Data

CONTROL UNIT DIMENSIONS [W x H x T, mm]	90 x 90 x 15
RADIO FREQUENCY [MHz]	868
RADION NETWORK RANGE [m]	Freifeld: 100 Gebäude: 20
MAINS VOLTAGE [V AC], [Hz]	230, 50
OPERATING VOLTAGE [V DC]	5
POWER CONSUMPTION, MAX. [W]	0,6
INGRESS PROTECTION	IPX2
PROTECTION CLASS	II

Setting and management of:

- Connected devices/sensors
- Fan directions of rotation
- Boost and pause settings
- Filter change intervals
- System resets

Quick access via keypad.

Connection of and communication between Controller and inner cover Connect

Controller Basic Connect wireless solution

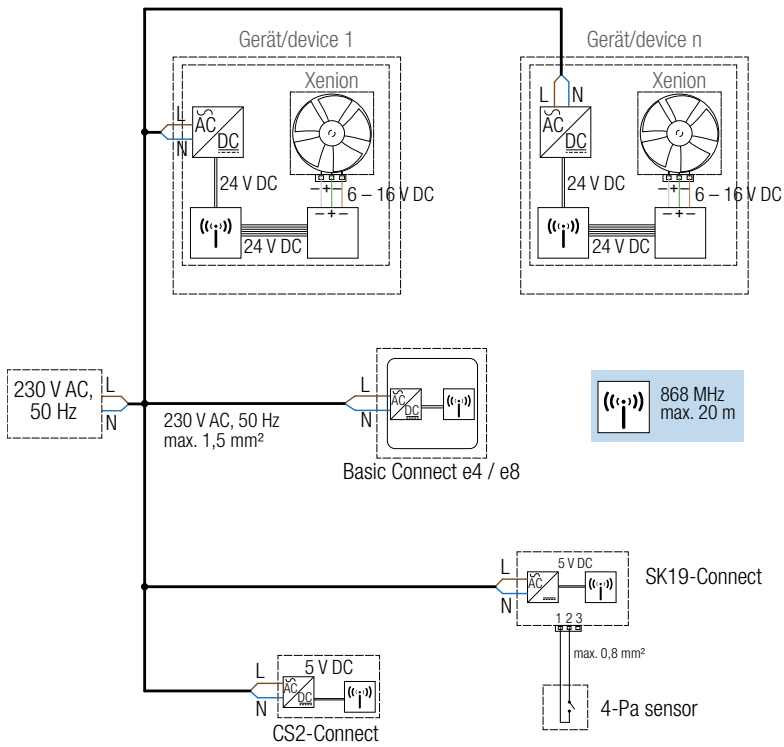

Note: The Basic Connect should be placed in the centre of the unit of use.

The maximum range from the controller to all components is 20 metres.

Controller Basic Connect cable variant (alternative)

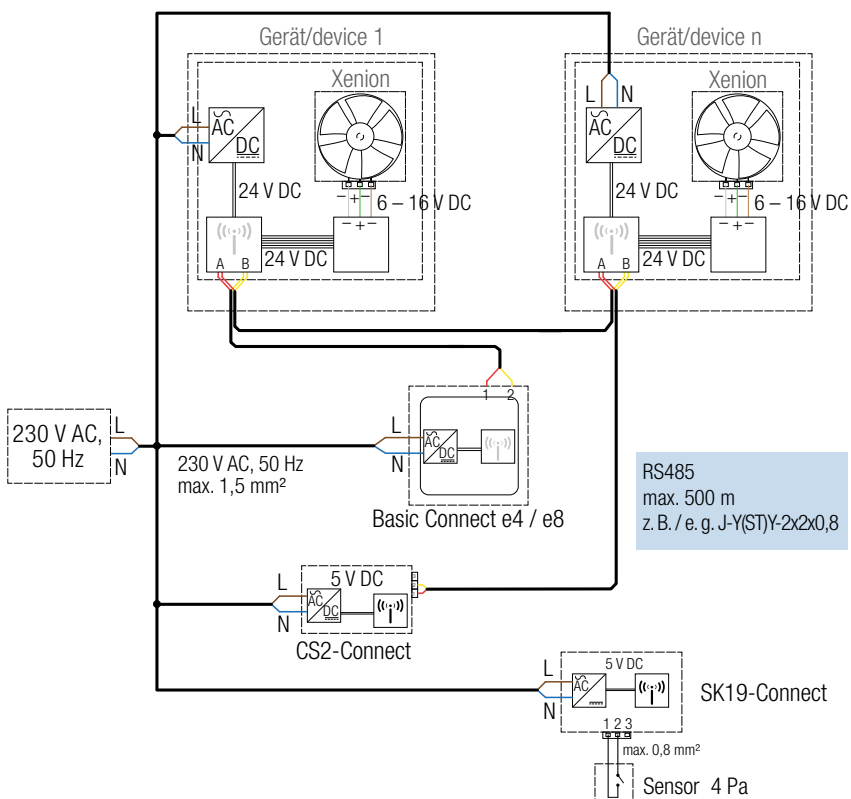

Inner cover Connect



Connect Flush-Mount inner cover, RAL 9016

Inner cover for radio-based control and programming of the decentralised iV-Smart+, iV14-Zero, iV-Light, and iV-Compact ventilation systems. Basis for integrating and using inVENTer Connect. Flush-mounted/surface-mounted design variants.

For switch-off, pause, basement ventilation, and summer mode, the inner cover is closed automatically.

Replaces the standard Flair/Flair SDE/Flair Zero or Light inner cover for the relevant devices.

Requires housing or Simplex-Connect.

Components

- Internal insert with automatic closure flap and G3 dust filter (ISO Coarse 45%). Compatible with UP/AP R-D160 housing (iV-Smart+/iV-Light/iV-Compact) or UP/AP R-D200 housing (iV14-Zero).
- Mounting plate with power supply unit, closure motor for automatic closure flap, local fan technology, and 868 MHz radio technology.

Accessories (obligatory)

- Wall mounting sleeve R-D160x495 incl. housing IB Connect,
- Wall mounting sleeve R-D160x745 incl. housing IB Connect,
- Wall mounting sleeve R-D200x495 incl. housing IB Connect,
- Wall mounting sleeve R-D200x745 incl. housing IB Connect,
- or Simplex Connect wall installation system

Accessories (optional)

- Pollen filter
- Activated carbon filter

Technical specifications

DIMENSIONS FLUSH-MOUNTED HOUSING W x H x D [mm]	258 x 258 x 66
DIMENSIONS SURFACE-MOUNTED HOUSING W x H x D [mm]	270 x 270 x 66
FLUSH-MOUNTED DESIGN INSTALLATION DEPTH [mm]	+ 38
RADIO FREQUENCY [MHz]	868
RADIO NETWORK RANGE [m]	Open field: 100 Building: 20
MAINS VOLTAGE [V AC], [Hz]	230, 50
OPERATING VOLTAGE [V DC]	18 – 24
CONTROLLER OUTPUT VOLTAGE [V DC]	6 – 16
POWER CONSUMPTION (MAX.) [W]	5
INGRESS PROTECTION/PROTECTION CLASS	IP 21/II

Dimensional drawings

Dimensional drawing IB Connect UP (flush) / Ø 160

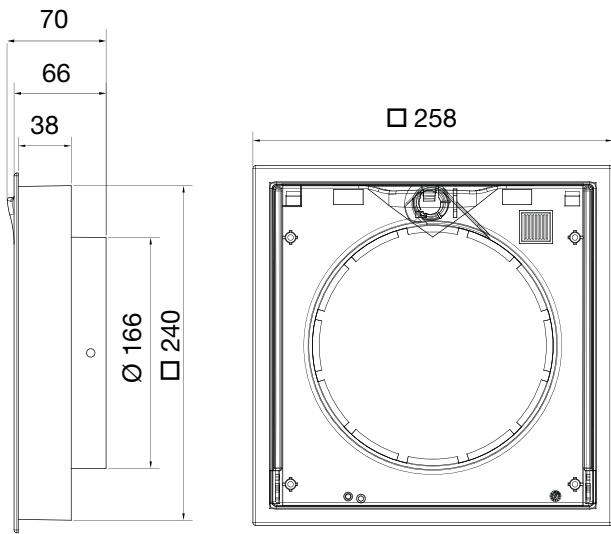

Dimensional drawing IB Connect AP (surface) / Ø 160

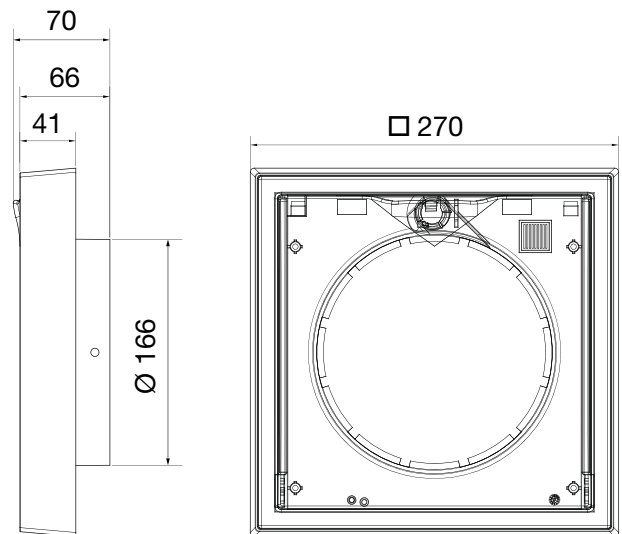

Dimensional drawing IB Connect UP (flush) / Ø 200

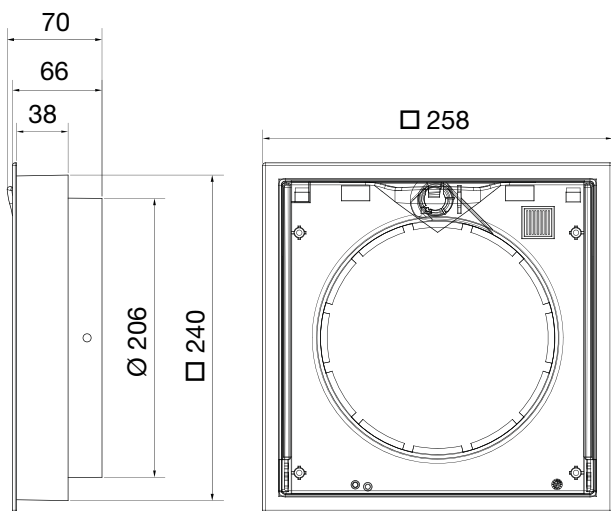

Maßzeichnung IB Connect AP (surface) / Ø 200

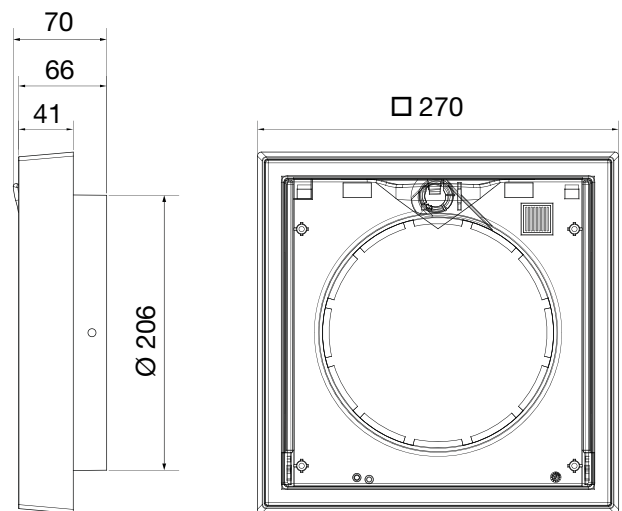

Inner cover Connect Twin+/Office/MaxAir



Connect Twin+/Office/MaxAir Flush-Mount inner cover, RAL 9016

Inner cover for radio-based control and programming of the decentralised iV-Twin+, iV-Office und iV14-MaxAir ventilation systems. Basis for integrating and using inVENTer Connect. Flush-mounted/surface-mounted design variants.

For switch-off, pause, basement ventilation, and summer mode, the inner cover is closed automatically.

Replaces the standard Flair / Flair Twin+ / Flair SDE / Flair XL inner cover for the relevant devices.

Requires housing or Simplex-Connect.

Components

- Internal insert with automatic closure flap and G4 dust filter (ISO Coarse 60%). Compatible with UP/AP R-D200 housing (iV-Twin+, iV14-MaxAir) or UP/AP R-D250 housing (iV-Office).
- Mounting plate with power supply unit, closure motor for automatic closure flap, local fan technology, and 868 MHz radio technology.

Accessories (obligatory)

- R-D200/250 x 495/745 incl. housing IB Connect,
- or Simplex Connect wall installation system

Accessories (optional)

- Pollen filter
- Activated carbon filter

Technical specifications

DIMENSIONS FLUSH-MOUNTED HOUSING W x H x D [mm]	327 x 325 x 61
DIMENSIONS SURFACE-MOUNTED HOUSING W x H x D [mm]	348 x 348 x 61
FLUSH-MOUNTED DESIGN INSTALLATION DEPTH [mm]	+ 43
RADIO FREQUENCY [MHz]	868
RADIO NETWORK RANGE [m]	Open field: 100 Building: 20
MAINS VOLTAGE [V AC], [Hz]	230, 50
OPERATING VOLTAGE [V DC]	18 – 24
CONTROLLER OUTPUT VOLTAGE [V DC]	6 – 16
POWER CONSUMPTION (MAX.) [W]	5
INGRESS PROTECTION/PROTECTION CLASS	IPX4 / II

Dimensional drawings

Dimensional drawing IB Connect Twin+ UP (flush)

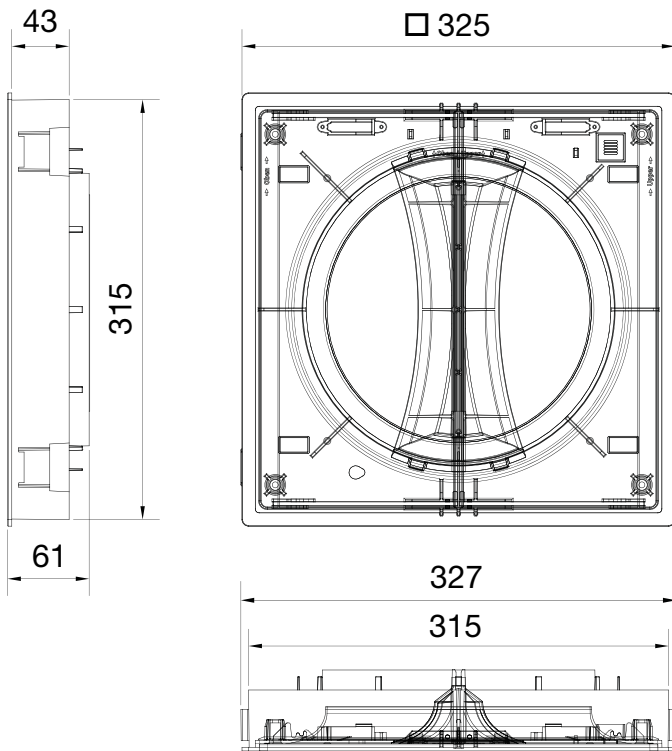

Dimensional drawing IB Connect Twin+ AP (surface)

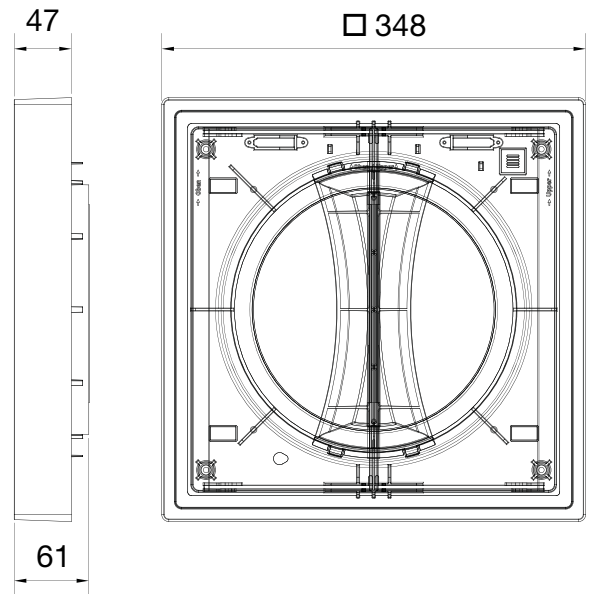

Dimensional drawing IB Connect Office/MaxAir UP (flush)

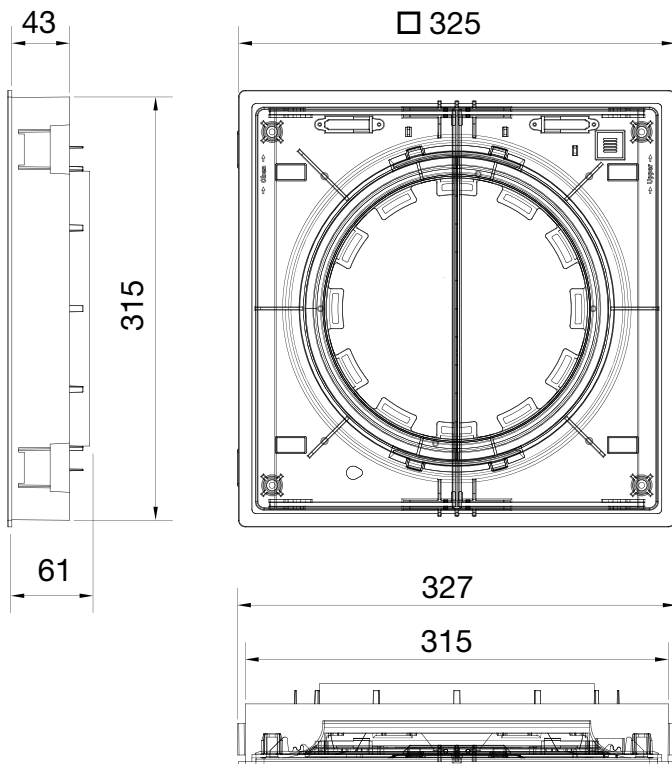

Dimensional drawing IB Connect Office/MaxAir AP (surface)

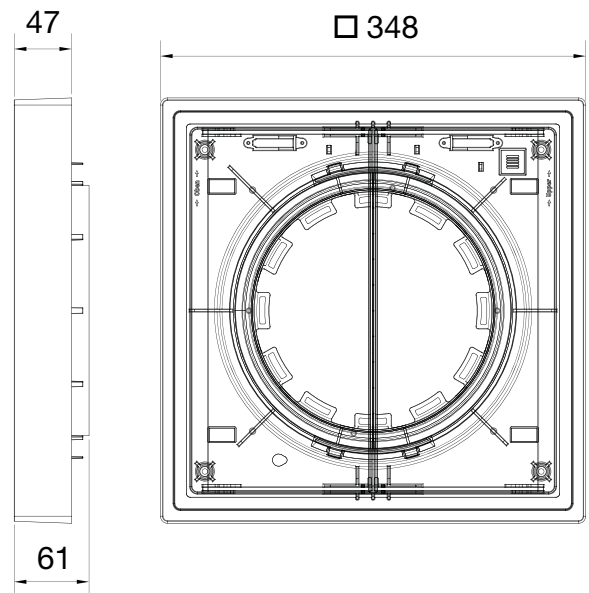

Installation diagrams ventilation systems with Connect inner cover

Installation diagram for iV14-Zero with Connect flush-mounted inner cover

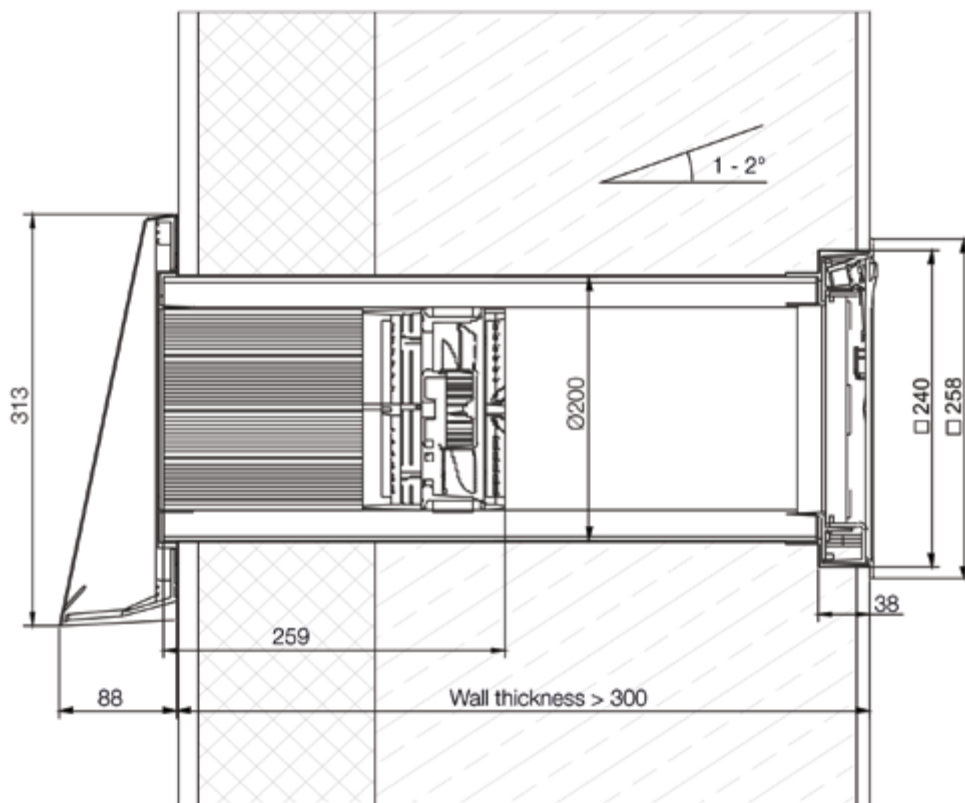

Installation diagram for iV14-Zero with Connect surface-mounted inner cover

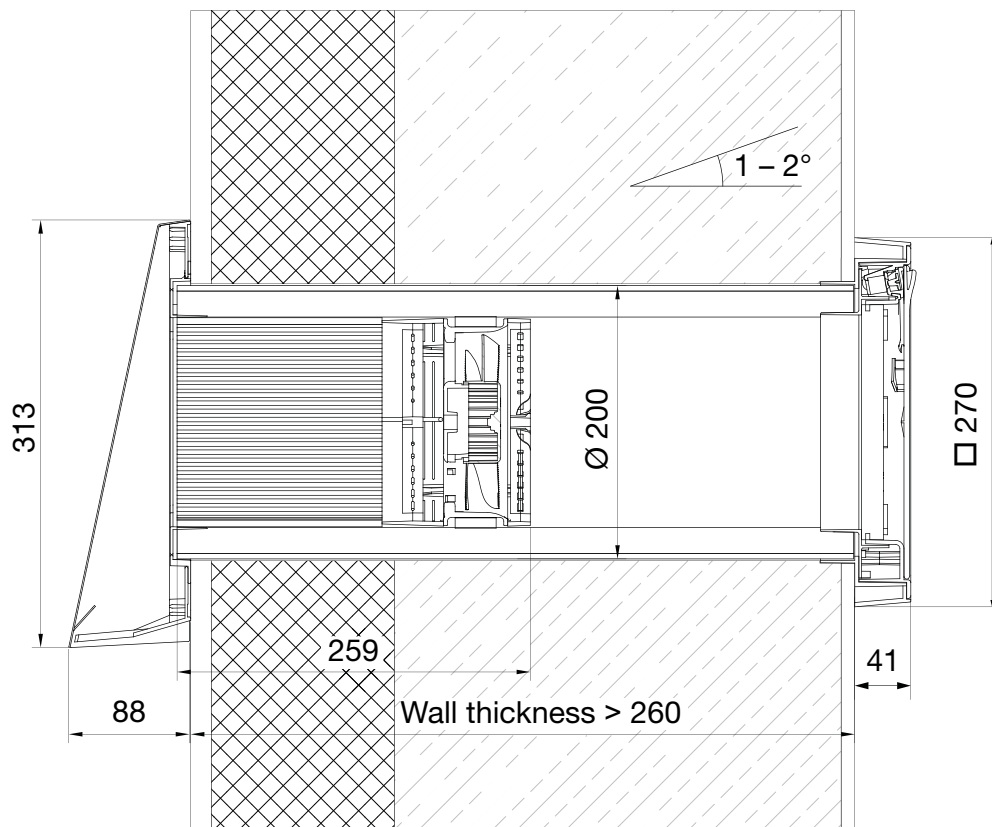

Installation diagram for iV-Smart+ with Connect flush-mounted inner cover

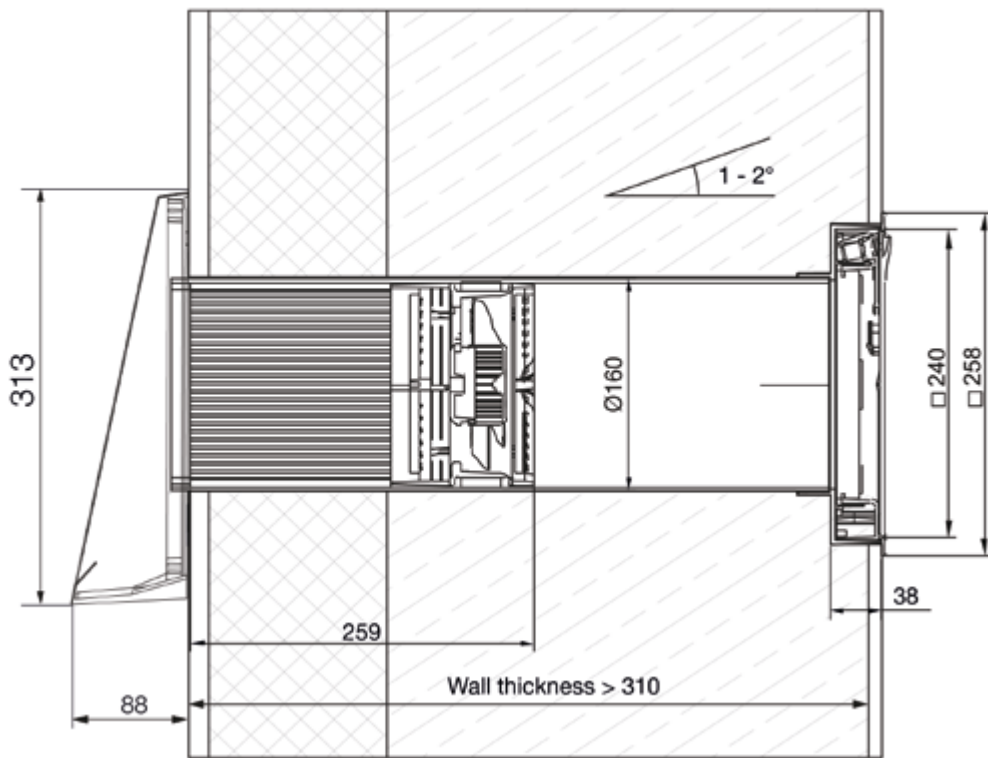

Controller

Installation diagram for iV-Smart+ with Connect surface-mounted inner cover

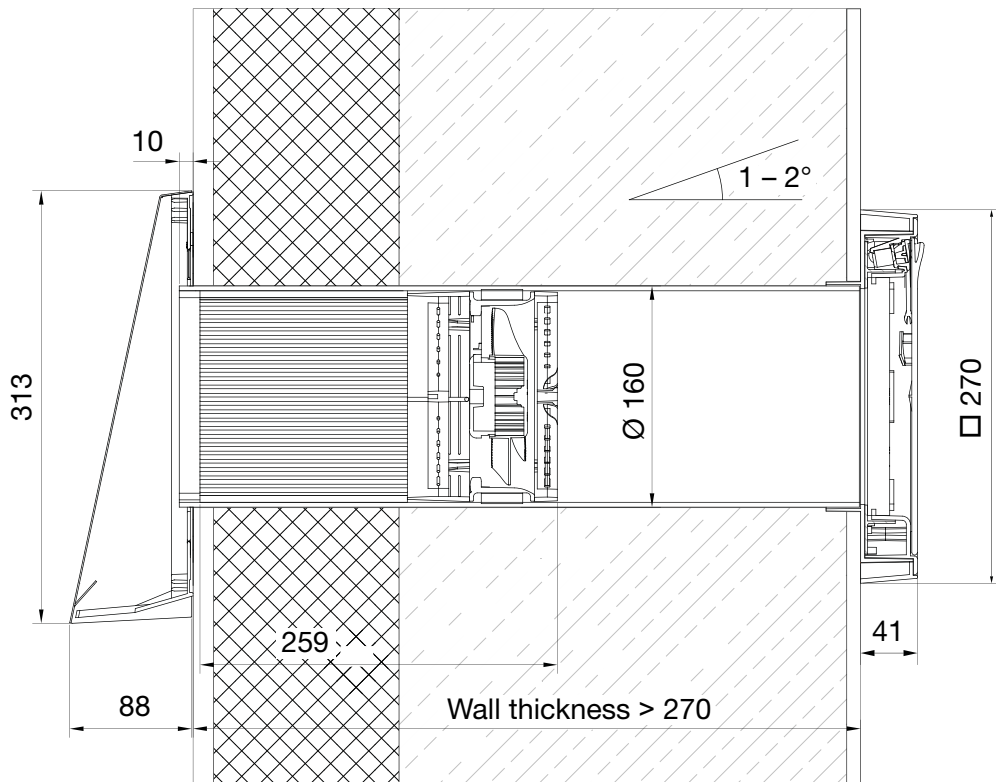

Installation diagram for iV-Twin+ with Connect flush-mounted inner cover

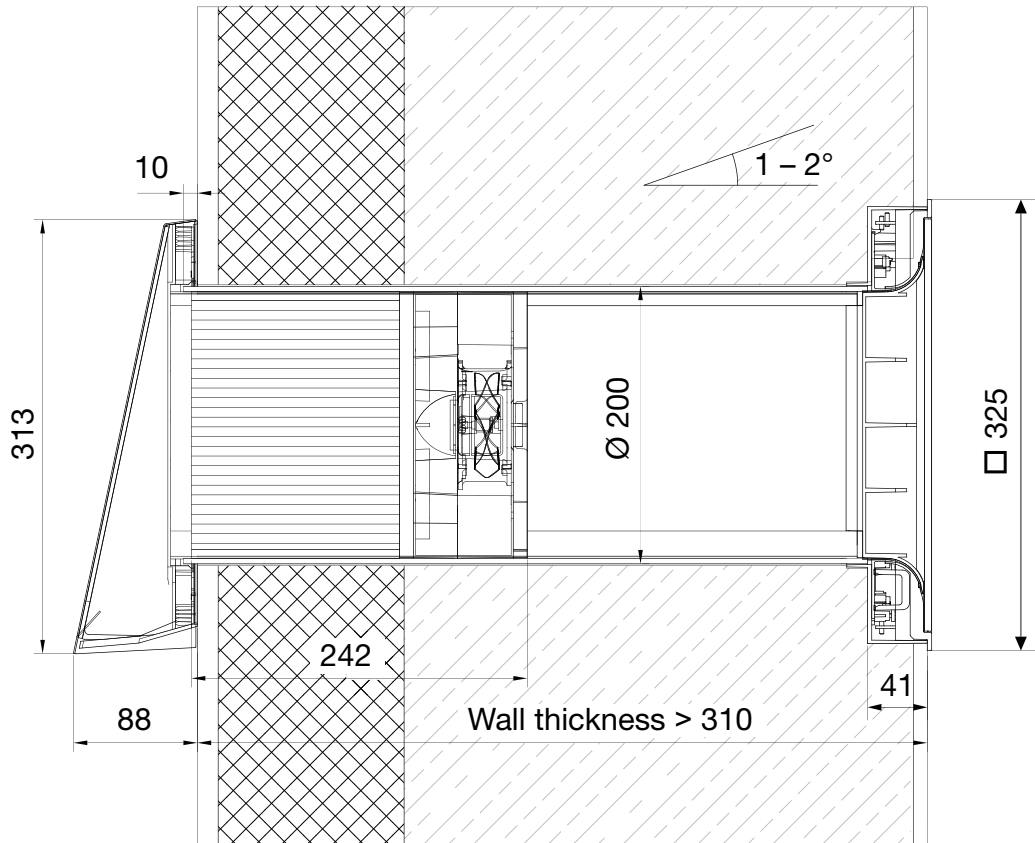

Installation diagram for iV-Twin+ with Connect surface-mounted inner cover

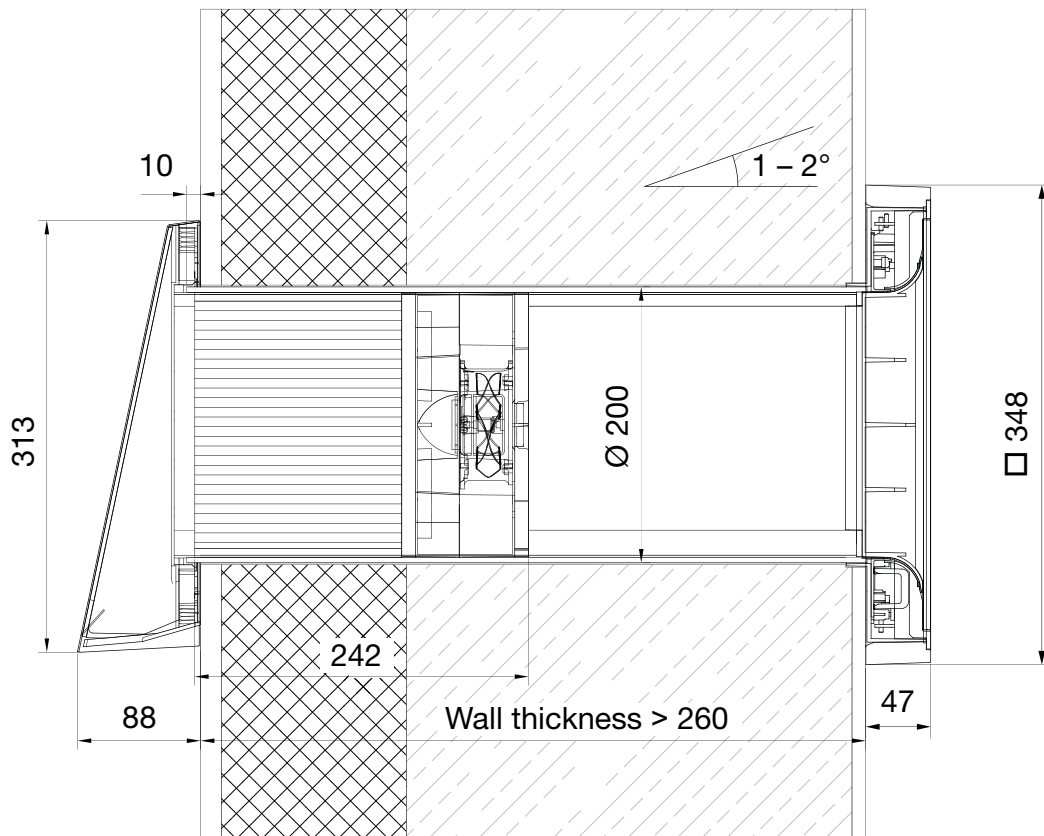

Installation diagram for iV-Office flush-mounted inner cover

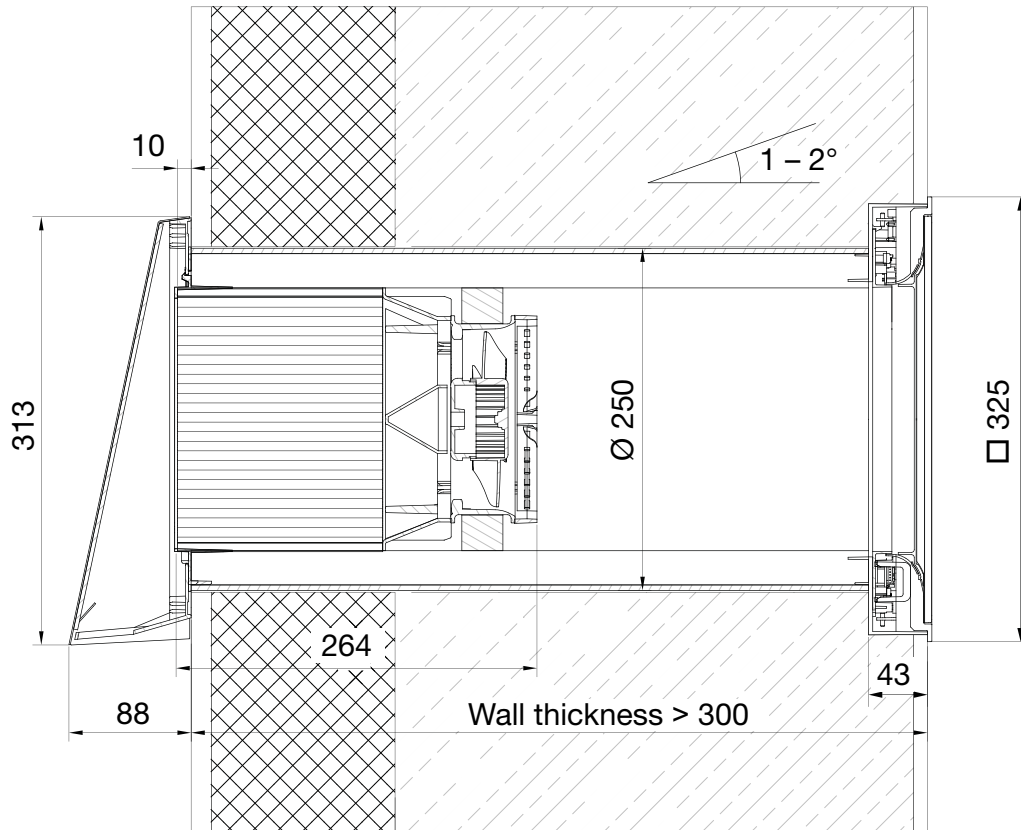

Installation diagram for iV-Office surface-mounted inner cover

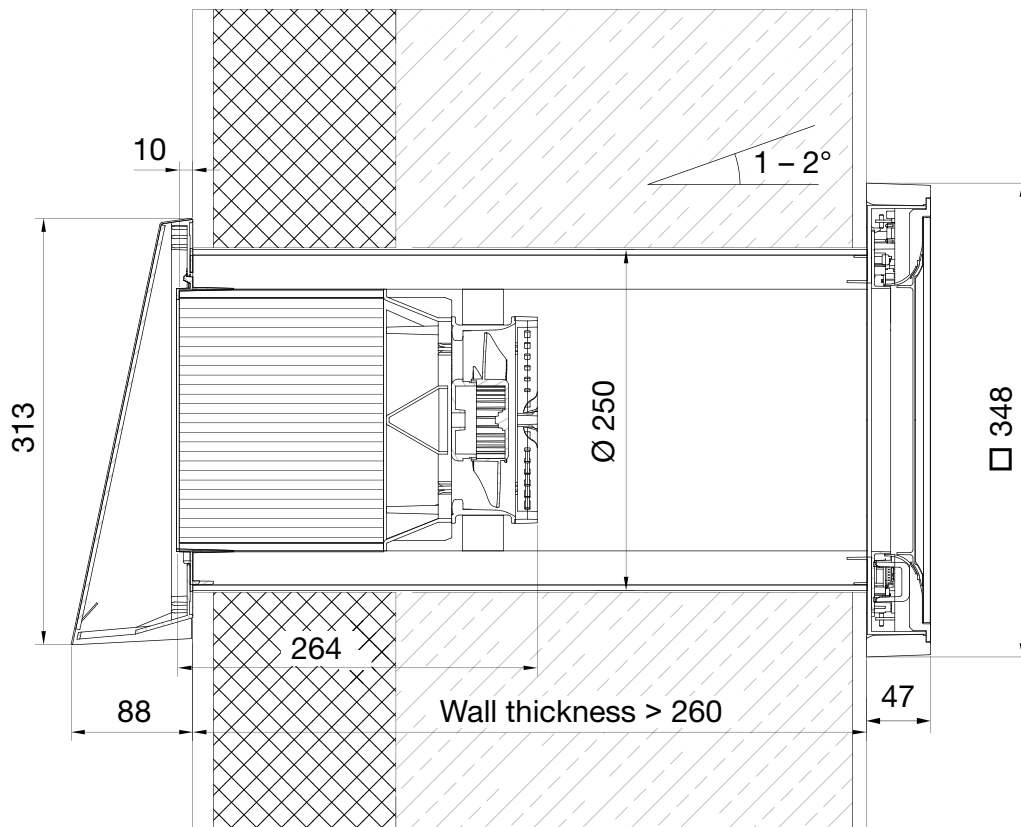

Installation diagram for iV14-MaxAir with Connect flush-mounted inner cover

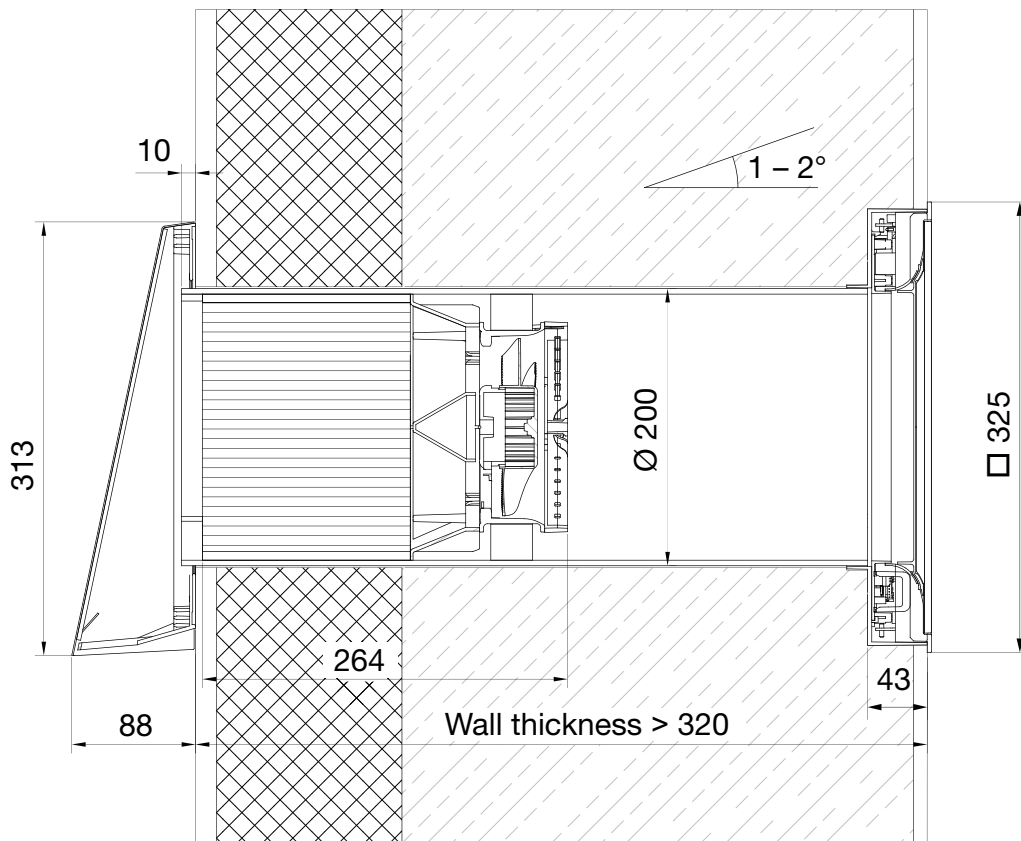

Installation diagram for iV14-MaxAir with Connect surface-mounted inner cover

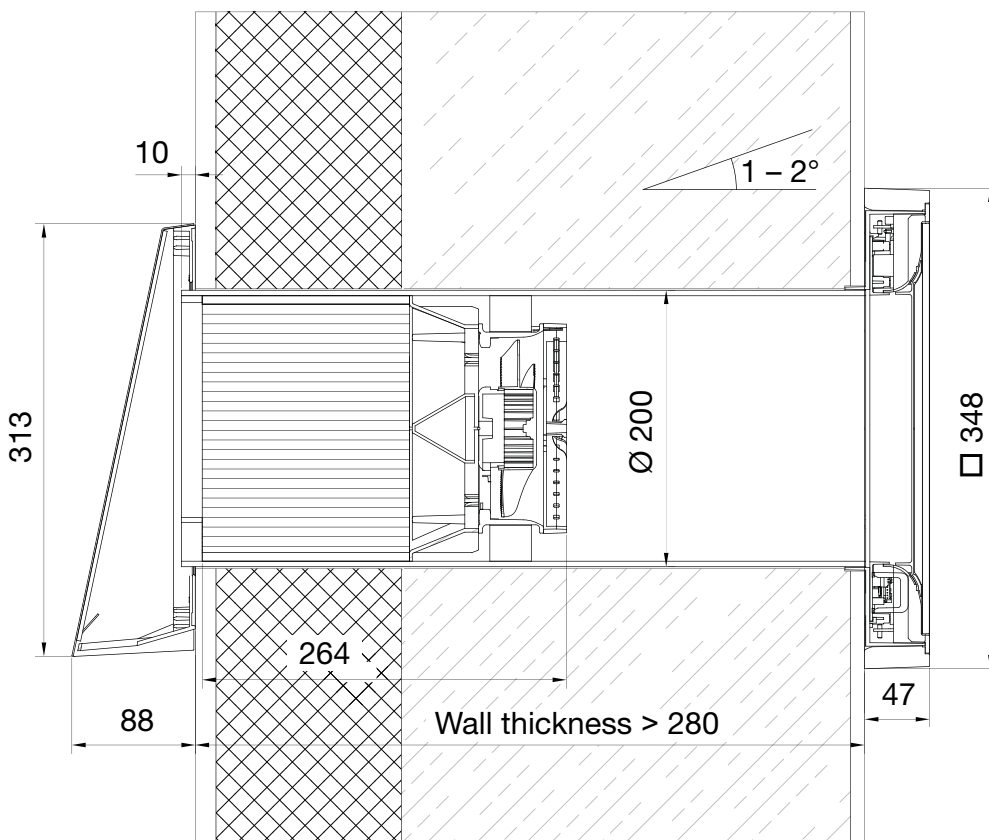

Ventilation zones with inVENTer Connect

Example of zone allocation with inVENTer Connect including ventilation profiles



Zoning and ventilation profile allocation are flexible, and the user can change them at any time.



Pairs of ventilation units should be planned for each ventilation zone (at least two). The ventilation zones can also be equipped with sensors (optional).

Basement ventilation with inVENTer Connect



Basement ventilation with heat recovery

This ventilation profile is suitable for all **heated rooms below ground level**. Its objective is to prevent mould by targeted humidity regulation for the ambient air. For basement ventilation, the **dew point is controlled automatically** by means of constant comparison of the relative humidity and temperature values of outdoor air with basement air. Based on these values, the system automatically calculates the optimal ventilation level and, taking environmental conditions into account, **switches autonomously between heat recovery and ventilation**. If humidity threatens to enter from outside, the system pauses and closes the automatic closure flaps. The closed flaps prevent passive inflow of humid outdoor air.



Basement ventilation without heat recovery

This ventilation profile is suitable for **unheated basements and storage rooms**. Its objective is to prevent mould by targeted humidity regulation for the ambient air. For basement ventilation, the **dew point is controlled automatically** by means of constant comparison of the relative humidity and temperature values of outdoor air with basement air. Based on these values, the system automatically calculates the ideal times for **using the ventilation function to remove moisture**. If humidity threatens to enter from outside, the system pauses and closes the automatic closure flaps. The closed flaps prevent passive inflow of humid outdoor air.

inVENTer Connect ventilation profiles

Ventilation profiles are assigned to the individual ventilation areas for maximum comfort and demand-driven ventilation. A ventilation profile is a programmable weekly timer with 3 variables:

- Time (7 days, 24 hours each)
- Ventilation level (1–4 or pause)
- Ventilation mode (heat recovery or ventilation/pause)

All ventilation profiles can be adapted to individual requirements. For maximum customization, a pre-defined profile can be completely re-assigned and programmed according to user needs.

The following ventilation profiles are pre-programmed to differentiate between working days and weekends:



Bedroom

Consideration of falling asleep and sleeping times



Children's room

Consideration of children's falling asleep and sleeping times



Bathroom

Consideration of times-of-use



Living-room

Consideration of times-of-use



Kitchen

Consideration of cooking and meal times



Holiday mode

Basic ventilation when the user is absent

There are also special ventilation profiles for which an FTS19 Connect Outdoor humidity/temperature sensor is required. In these ventilation profiles, ventilation behaviour will be determined based on temperature and humidity variables in two environments (inside the usage unit and outdoors). Using basement ventilation profiles also requires a humidity/temperature sensor in the basement ventilation zone. The user cannot program the automatic ventilation profiles, which function entirely independently.



Basement ventilation with heat recovery

- for heated rooms below ground level
- Dew point control



Basement ventilation without heat recovery

- for unheated basements and storage rooms
- Dew point control



Summer operation

- for automatic ventilation at low outdoor temperatures in hot summer months
- Ventilation function activates at an outdoor temperature of 10 °C

MZ-Home Controller



MZ-Home Controller

MZ-Home Controller

Multi-zone controller for up to 16 inVENTer ventilation units. Ventilation zones defined via associated Clust-Air® modules (CAMs). Up to four CAMs can be connected.

Five-year manufacturer's warranty.

Equipped with: Weekly timer, power display for each zone, external interface for integration into an existing home automation system or connection to a voltage-free switch, filter replacement intervals, operating hours counter.

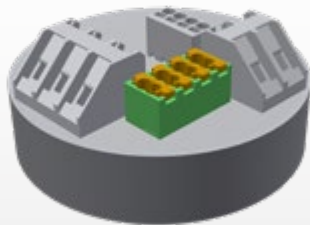

Clust-Air®-Module

Clust-Air® module

Module for the implementation of a zone control. The MZ-Home control unit can be connected for further ventilation zone control.

A ventilation zone encompasses:

2–4 x iV14-Zero/iV-Smart+/iV-Light/iV-Compact or
1–2 x iV-Twin+/iV-Office/iV14-MaxAir.

Humidity/temperature sensor included.

Further sensors can optionally be integrated at the external input.

Equipment and functions

The basic MZ-Home version contains the following:

- Controller
- 1x Clust-Air® module incl. humidity and temperature sensor for automatic control
- Switching power supply for control cabinet installation

Operating modes:

- Heat recovery
- Ventilation
- Pause
- Dehumidification

Accessories (optional)

- Clust-Air-Module CAM17
- CS1 CO₂ sensor
- Socket dry wall 68x61
- Flush-mounted socket 60x66
- Bus cable J-Y(ST)Y2x2x0.8 Lg
- Round cable LiYY-O 3x0,75 (33 m)

Planning information

- Division of the residential unit into max. 4 areas (zones) to be ventilated per controller MZ-Home
- Assign ventilation units operated in pairs to the same zone
- Connection of the Clust-Air modules CAM in a row
- Mounting humidity and temperature sensors in the air volume flow of the room

Control unit technical specifications

OPERATING VOLTAGE [V DC]	24
CONTROL BUS VOLTAGE [V DC]	24
POWER CONSUMPTION (MAX.) [W]	0.5 (four zones)
CONTROL UNIT DIMENSIONS [W x H x D, mm]	119 x 119 x 27.5

Switching power supply technical specifications

INPUT [V AC], [Hz]	230, 50
OUTPUT [V DC]	24
PROTECTION CLASS/INGRESS PROTECTION	II/IP20

Clust-Air® CAM17 module technical specifications

OPERATING VOLTAGE [V DC]	24
CONTROL BUS OUTPUT VOLTAGE [V DC]	24; four-pin
FAN BUS OUTPUT VOLTAGE [V DC]	max. 16; three-pin
POWER CONSUMPTION (MAX.) [W]	18
EXTERNAL SWITCHING CONTACT (OPTIONAL)	Voltage-free NO contact
ANALOGUE INPUT (OPTIONAL)	
OUTPUT VOLTAGE [V DC]	0 – 10
RESOLUTION [bit]	10

Clust-Air technology functionality

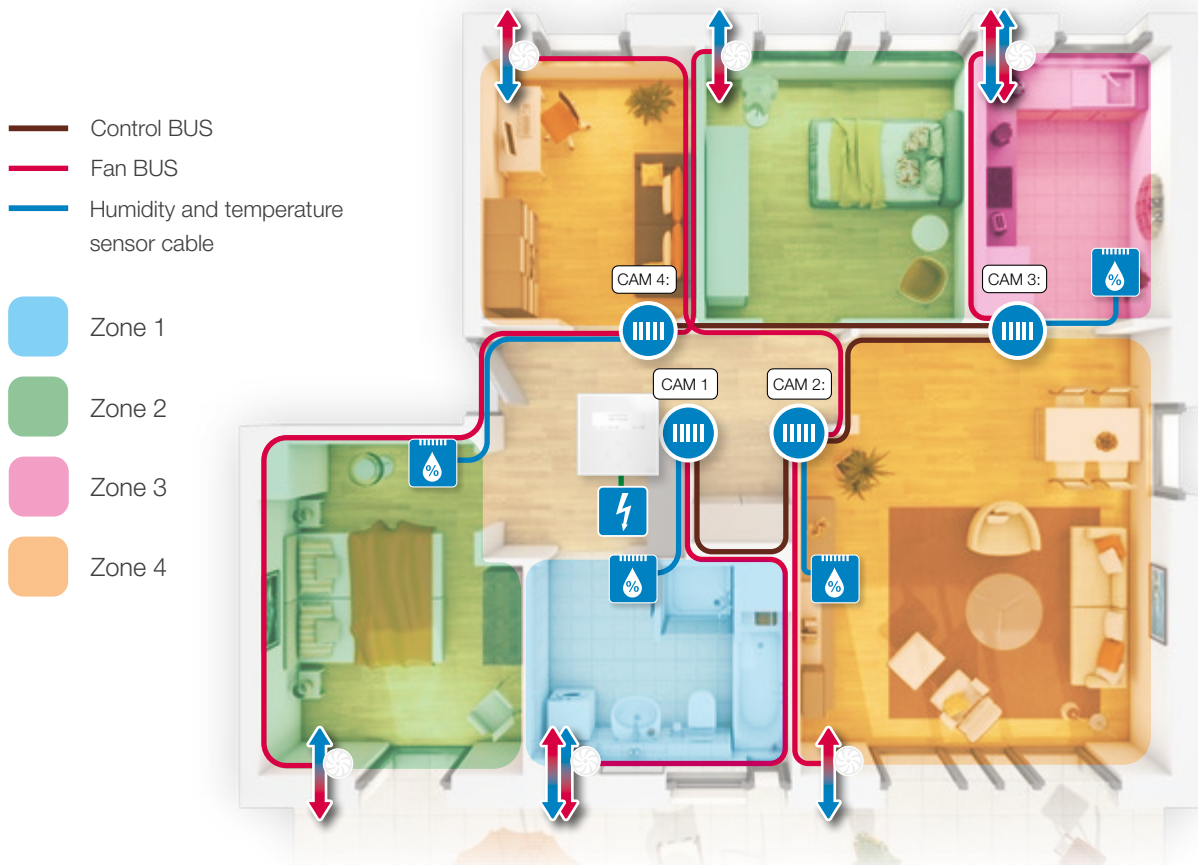

Maximum cable lengths

Operating voltage cable power supply unit – controller: max. 100 m

Control BUS

Star connection

Between CAM and iV-Smart+/iV14-Zero/

iV-Light/iV-Compact

max. 33 m

Between CAM and iV-Office/iV14-MaxAir/iV-Twin+

max. 25 m

Connection in series/between controller and last ventilation unit

CAM with 4 x iV-Smart+/iV14-Zero/iV-Light/iV-Compact

max. 15 m

CAM with 2 x iV-Smart+/iV14-Zero/iV-Light/iV-Compact

max. 25 m

CAM with 2 x iV-Office/iV14-MaxAir/iV-Twin+

max. 15 m

Principle diagrams for laying cables

Example: Ventilation unit / series connection

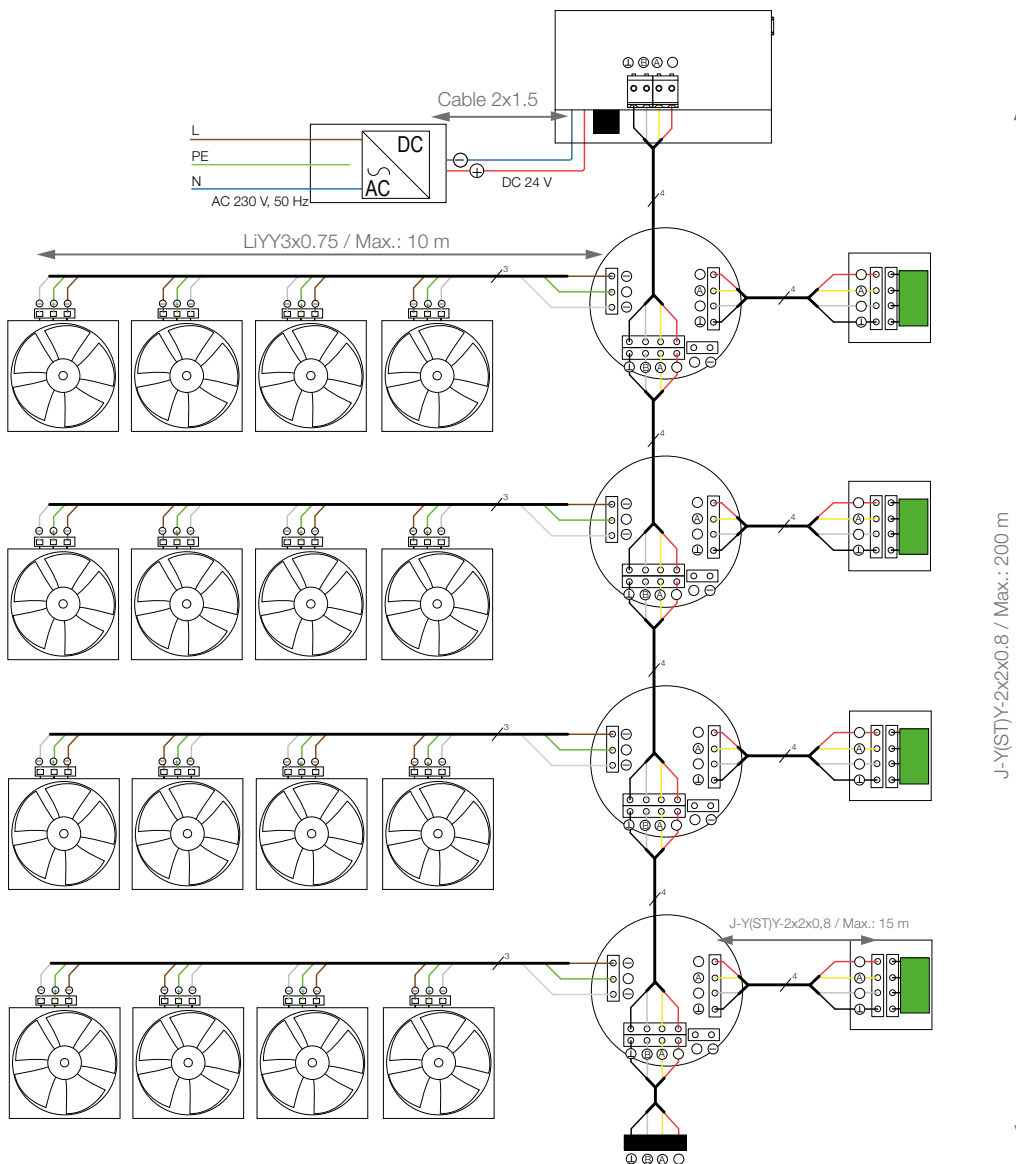
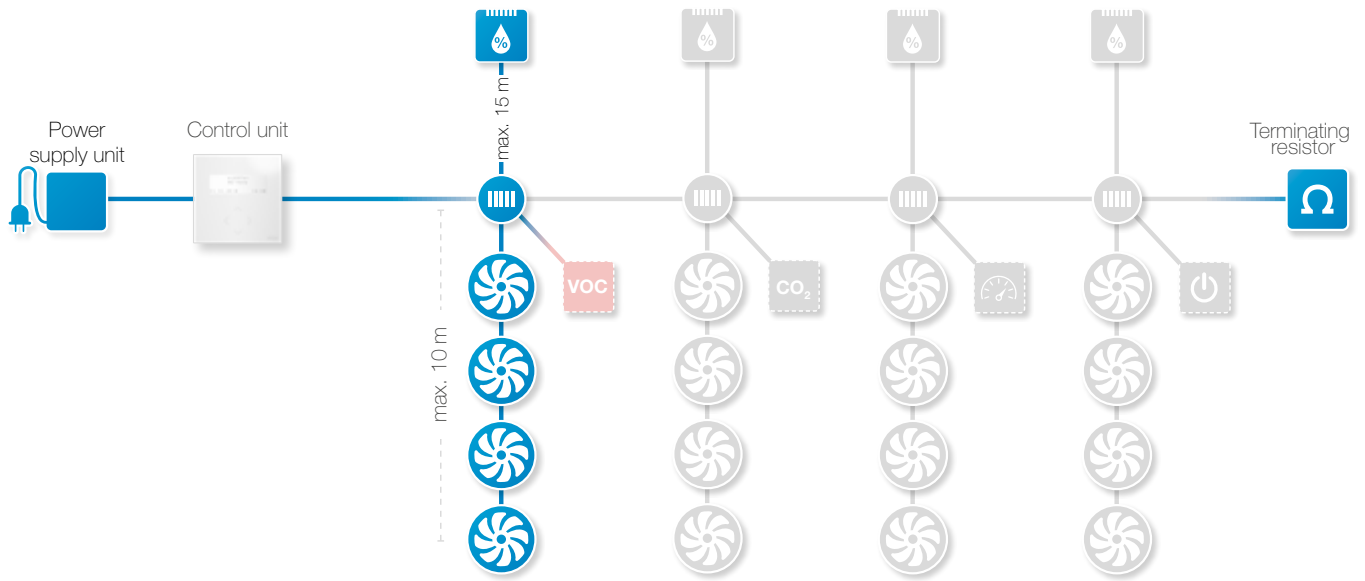

Example: Ventilation unit / star-shaped connection

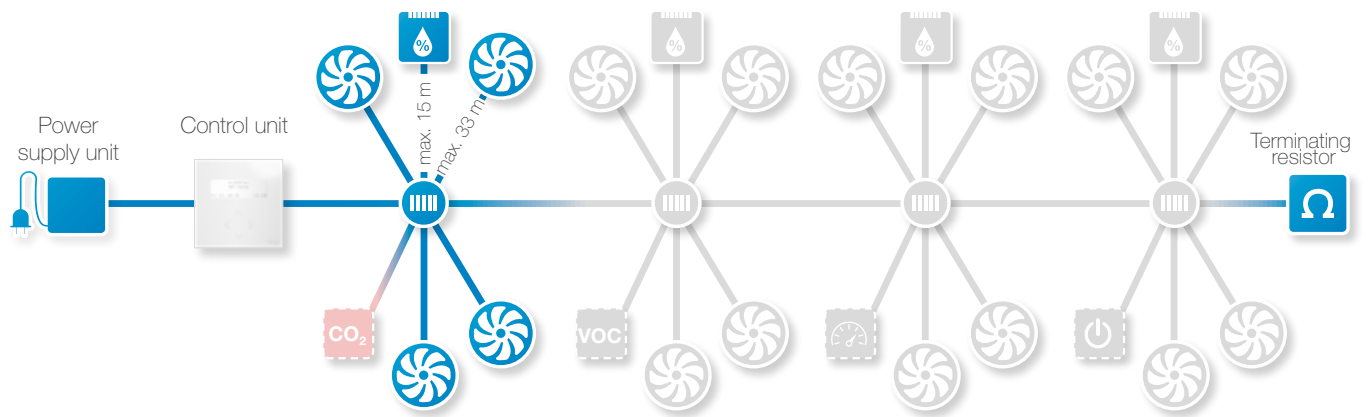

Example: Ventilation unit / star-series connection

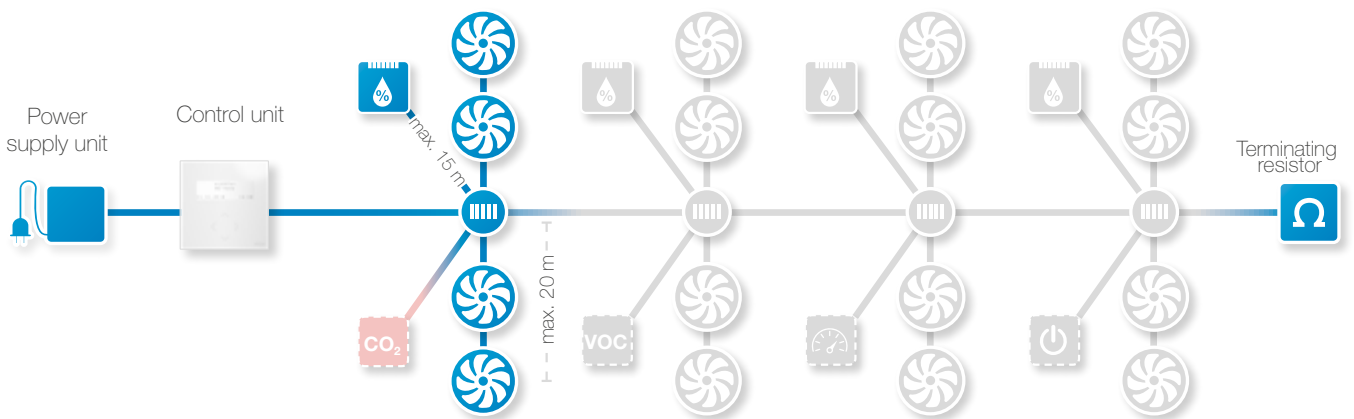

Exhaust air systems

without heat recovery



Wall Mounting Kit aV100

iVENTer exhaust air system:

aV100 wall mounting kit + Avio N 100 | Pulsar (Basic) | Aviant

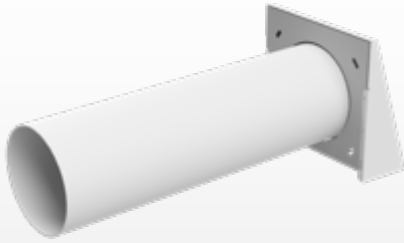

Wall Mounting Kit aV100

Wall mounting kit for mountin exhaust fans Avio N 100, Pulsar Basic, Pulsar, and Aviant. Without heat recovery. With integrated noiseless non-return valve. For installation in the outer wall.

With weather protection hood as outer cover.

Alternative: Corner duct with stainless steel grille as reveal variant for a concealed external finish.

Alternative: Nordic facade end with stainless steel outer grille for integration into clinker facades or outer walls with insulation.

Exterior wall connection available in white (RAL9016), grey (RAL9006), anthracite (RAL7016), and special RAL colours.

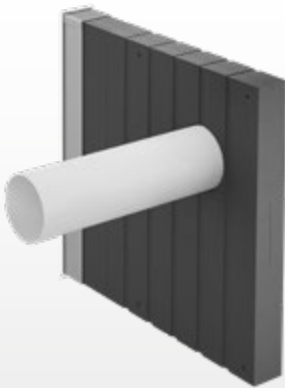

aV100 Corner wall mounting kit

aV100 technical specifications

WALL OPENING DIAMETER [mm]	115
WALL THICKNESS [mm]	> 180
WALL MOUNTING SLEEVE DIMENSIONS [Ø, length, mm]	103, 495/745
WEATHER PROTECTION HOOD DIMENSIONS [W x H, mm]	182 x 198

aV100 Corner technical specifications

WALL OPENING DIAMETER [mm]	115
WALL THICKNESS/INSULATION [mm]	> 180/> 70
WALL MOUNTING SLEEVE DIMENSIONS [Ø, length, mm]	103, 495/745
SOFFIT GRILLE DIMENSIONS [WxH, mm]	70 x 512
CORNER DUCT DIMENSIONS [W x H, length, mm]	60 x 490, 515

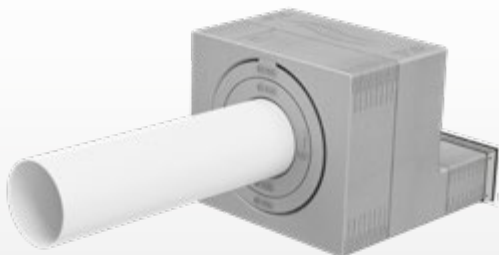

aV100 Nordic wall mounting kit

aV100 Nordic technical specifications

WALL OPENING DIAMETER [mm]	115
WALL THICKNESS/INSULATION [mm]	> 160/> 120
WALL MOUNTING SLEEVE DIMENSIONS [Ø, length, mm]	103, 495/745
OUTER GRILLE DIMENSIONS [W x H, mm]	290 x 89
FACADE END DIMENSIONS [W x H x D, mm]	280x240x315

aV100 Standard wall opening wall mounting kit –
Interior view

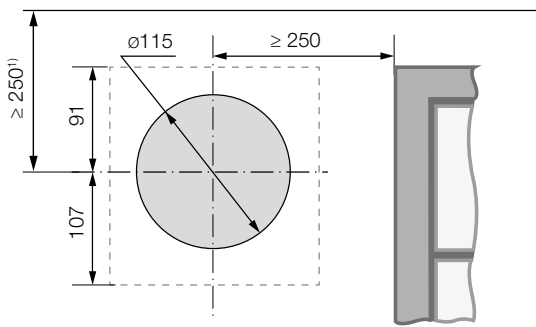

- 1) Minimum distance to components on the inner and outer wall
- External finish contour

aV100 Corner wall opening wall mounting kit –
Interior view

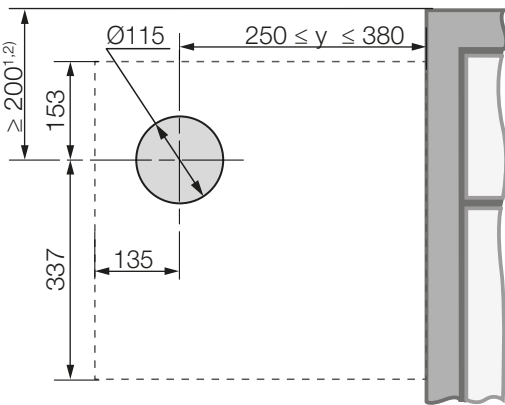

- 1) Minimum distance to components on the inner wall
- 2) Mind insulation thickness and any shutters on the outer wall
- External finish contour

aV100 Nordic wall opening wall mounting kit –
Interior view

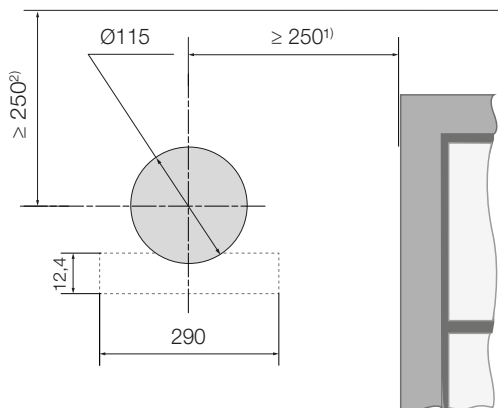

- 1) Minimum distance to components on the inner wall
- 2) Minimum distance to components on the outer wall
- Outer grille contour

Remarks

During installation, observe the minimum distances in the illustrations on the left to ensure that the system can be installed.

Install in the room's air volume flow. Installable exhaust fans can be installed in Areas 1–3 according to VDE 0100.

Ensure frontal minimum distance for system cleaning.
Minimum distance to other ventilation systems/components: 1.2 m. Insulation on the flat duct: at least 10 mm

All assembly and operating instructions and further information can be found at www.inventer.de



DXF / DWG / STP

Pulsar Basic exhaust air unit



Low-noise exhaust air fan for wall installation with the aV100 wall mounting kit or installation in the suspended ceiling.

Easily accessible fan unit for easy cleaning. Meets mechanical safety requirements according to DIN EN 60335-2-80. May be installed in areas 1 to 3 in bath and shower rooms according to VDE 0100.

With preconfigured air volume flows for peak humidity loads and changing lighting: humidity sensor 100 m³/h, light sensor 60 m³/h with 15-minute time delay.

Can be continuously operated for continuous ventilation.

Five-year manufacturer's warranty.



Pulsar Basic interior view

Dimensions

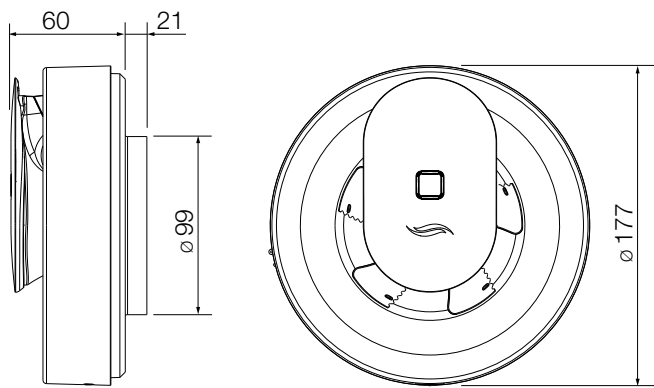

Technical specifications

WALL MOUNTING SLEEVE DIAMETER [mm]	100 – 140
EXHAUST AIR VOLUME FLOW [m ³ /h]	110
INPUT VOLTAGE [V AC, Hz / V DC]	230, 50 / 12
POWER CONSUMPTION [W]	4
SOUND PRESSURE LEVEL [dB(A)]	17 – 20
INNER COVER DIMENSIONS [Ø, mm]	177
INGRESS PROTECTION	IP44
PROTECTION CLASS	II
PROTECTION RANGE	1 – 3

Circuit diagrams

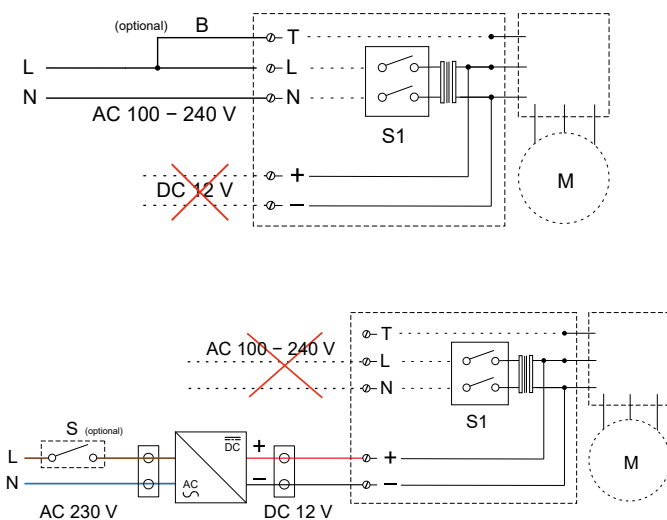

Air volume flow/pressure curve

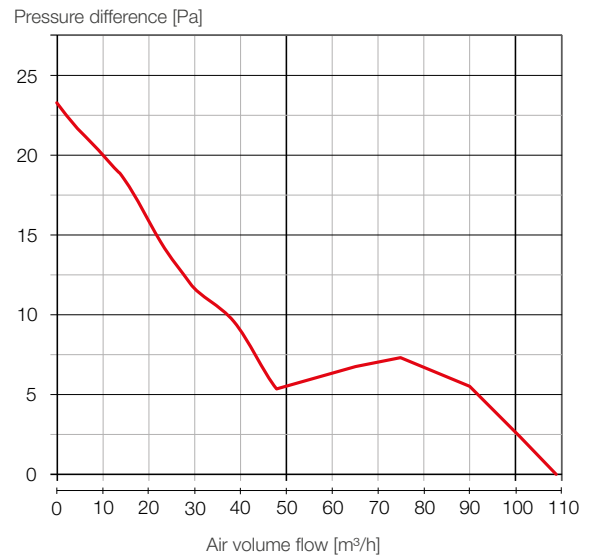

Pulsar exhaust air unit



Pulsar front view

Download app
inVENTer Mobile:



You can find detailed information about the requirements for the operating system in the stores and on www.inventer.de

Low-noise exhaust air fan for wall installation with the aV100 wall mounting kit or installation in the false ceiling. With app control (iOS, Android). Integrated humidity sensor and light sensor.

inVENTer Mobile app controls ventilation intensity, humidity and light sensor, time delay pause time settings.

Power can be supplied via mains voltage (230 V, 50 Hz) or safety extra-low voltage (12 V DC). Power supply unit for safety extra-low voltage connection optionally available.

Meets mechanical safety requirements according to DIN EN 60335-2-80. May be installed in areas 1 to 3 in bath and shower rooms according to VDE 0100.

Five-year manufacturer's warranty.

Dimensions

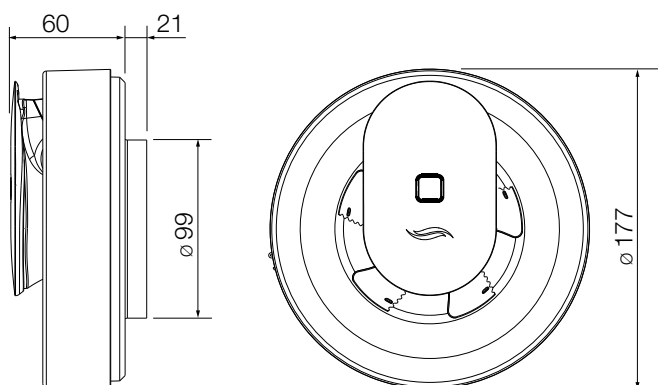

Technical specifications

WALL MOUNTING SLEEVE DIAMETER [mm]	100 – 140
EXHAUST AIR VOLUME FLOW [m³/h]	110
INPUT VOLTAGE [V AC, Hz / V DC]	230, 50 / 12
POWER CONSUMPTION [W]	4
SOUND PRESSURE LEVEL [dB(A)]	17 – 20
INNER COVER DIMENSIONS [Ø, mm]	177
INGRESS PROTECTION	IP44
PROTECTION CLASS	II
PROTECTION RANGE	1 – 3

Exhaust air systems

Circuit diagrams

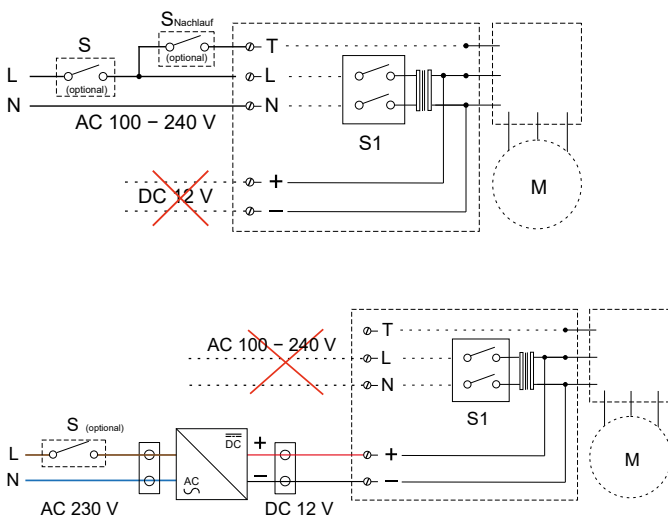

Air volume flow-pressure curve

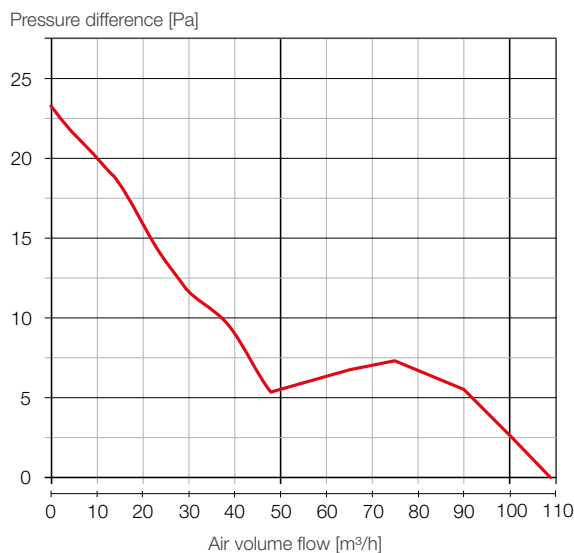

Aviant exhaust air unit



Aviant interior view

Download app
inVENTer Mobile:



You can find detailed information about the requirements for the operating system in the stores and on www.inventer.de

Low-noise exhaust air fan for wall installation with the aV100 wall mounting kit or installation in the suspended ceiling. With app control system (Android, iOS).

Easily accessible fan unit for easy cleaning. Meets mechanical safety requirements according to DIN EN 60335-2-80. May be installed in areas 1 to 3 in bath and shower rooms according to VDE 0100.

Control with the app or on the device. Sensor trio: Humidity, light, odour. Odour sensor target gases: Methane, hydrogen, isobutane, ethanol.

Sensor sensitivity adjustment.

Basic ventilation cycles at 26 hours in idle mode

Permanent operation for continuous ventilation possible.

Five-year manufacturer's warranty.

Dimensions

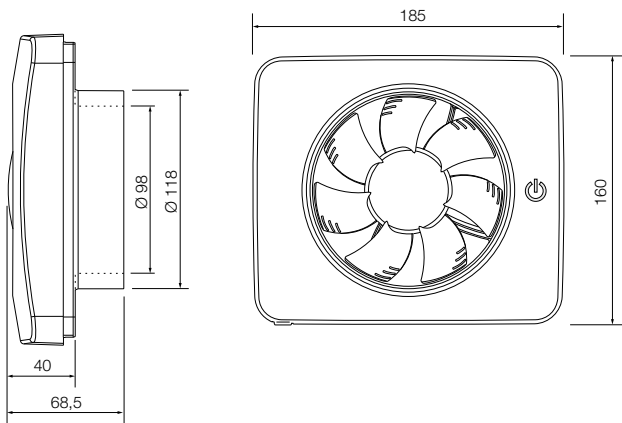

Technical specifications

WALL MOUNTING SLEEVE DIAMETER [mm]	100/125
EXHAUST AIR VOLUME FLOW [m³/h]	95/115 (without IP)
MAINS VOLTAGE [V AC, Hz]	230, 50
POWER CONSUMPTION [W]	5
SOUND PRESSURE LEVEL [dB(A)]	17 – 20
INNER COVER DIMENSIONS [W x H, mm]	182 x 157
INGRESS PROTECTION	IP44
PROTECTION CLASS	II
PROTECTION RANGE	1 – 3

Circuit diagrams

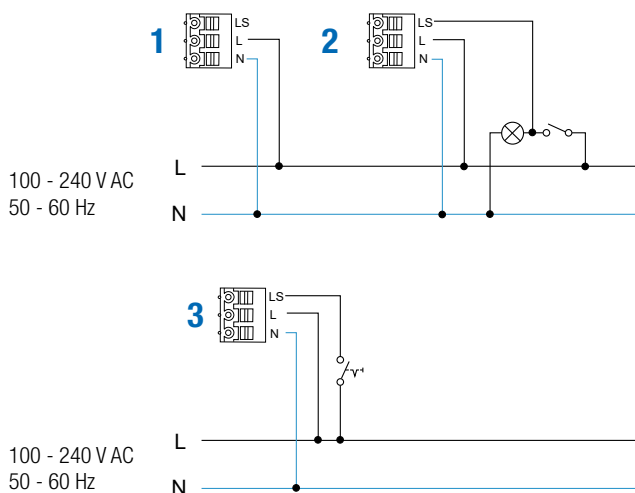

Air volume flow/pressure curve

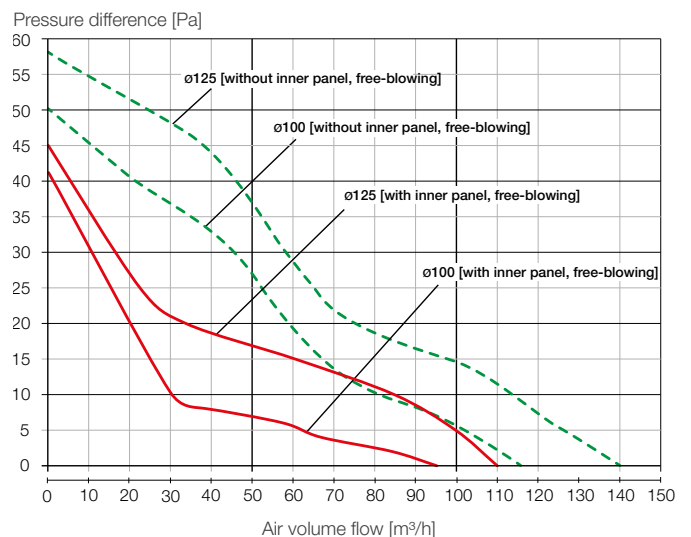

Avio N 100 exhaust air unit



Low-noise exhaust air fan for ventilation of damp rooms with outside window.

Wall installation in the wall installation set aV100 or installation in the suspended ceiling.

Overshoot time adjustable from 5 to 30 minutes. A HYG12 hygostat for humidity control can also be integrated. Install the ventilation unit in the room's air volume flow. Integrated air flow cone for flow guidance for particularly quiet operation.

Combination with light switch possible or separate operation via switch or push-button.



Avio N 100 interior view

Dimensions

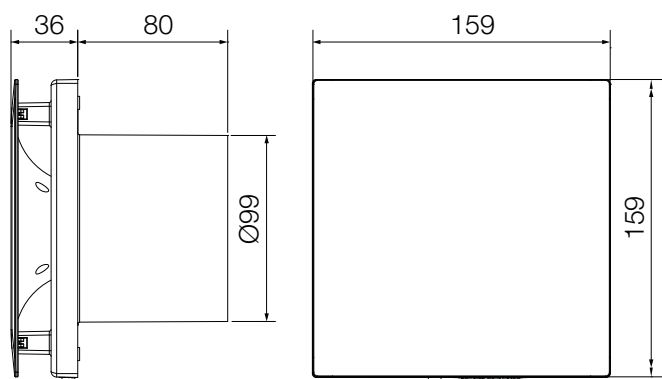

Technical specifications

WALL MOUNTING SLEEVE DIAMETER [mm]	100
EXHAUST AIR VOLUME FLOW [m³/h]	75
MAINS VOLTAGE [V AC, Hz]	230, 50
POWER CONSUMPTION [W]	6.4
SOUND PRESSURE LEVEL [dB(A)]	28
INNER COVER DIMENSIONS [W x H, mm]	159 x 159
INGRESS PROTECTION	IP44
PROTECTION CLASS	II
PROTECTION RANGE	1 – 3

Connection diagrams

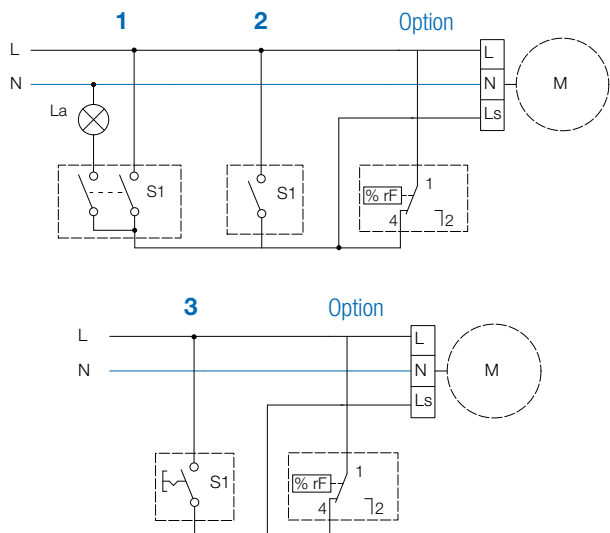

Air volume flow/pressure curve

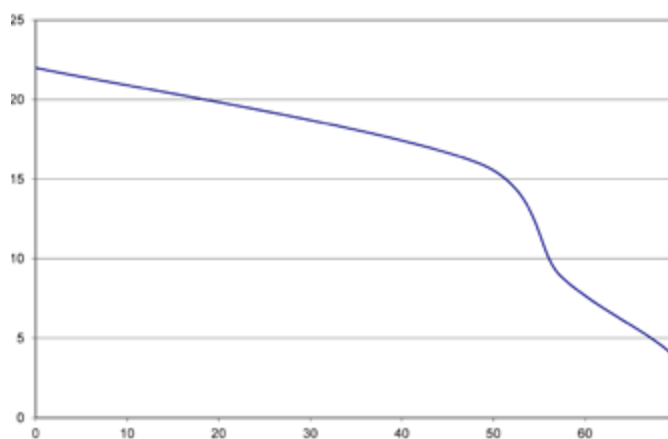

Taris exhaust air unit



Taris flush-mounted version (UP), interior view



Taris surface-mounted version (AP), interior view

Exhaust air unit for ventilating interior wet rooms without external windows (DIN 18017-3) to the outside or for integration into a common exhaust air duct (multi-storey building). Without heat recovery.

Permitted installation in area 1 in bathrooms and shower rooms in accordance with DIN VDE 0100.

Installation in supply shaft, room ceiling or on the wall possible. Flush-mounted and surface-mounted variants.

Radial or axial fan insert design. Optionally with second room connection (with fan insert 100 m³/h).

Also available with humidity and air quality sensor.

Fan insert selectable with extract air volume flow:

- single-stage 60 m³/h
- two-stage 30/60 m³/h (suitable for permanent operation)
- single-stage 100 m³/h

5-year manufacturer's guarantee.

The Taris extract air fan can be used in ventilation systems in accordance with DIN 18017-3 with the fan inserts 30/60 m³/h and 60 m³/h can be used. These have been tested for use up to an air flow rate of 60 m³/h under full load and an application for approval has been submitted to the German Institute for Building Technology (DIBt).

The fan insert with 100 m³/h was measured in accordance with the regulations of DIN 18017-3.

Accessories (optional)

- Taris wall installation set
- Mounting bracket
- Frame
- Inner cover for second room connection

Fire protection components fulfil class K90 according to DIN 18017-3.

Technische Daten

TARIS UP HOUSING DIMENSIONS [W x H x T, mm]	242 x 242 x 90
TARIS FLUSH-MOUNTED FIRE PROTECTION HOUSING DIMENSIONS [W x H x T, mm]	262 x 278 x 105
TARIS SURFACE-MOUNTED HOUSING DIMENSIONS [W x H x T, mm]	256 x 256 x 97
INNER COVER DIMENSIONS [W x H, mm]	251 x 251
EXHAUST AIR VOLUME FLOW [m ³ /h]	60 / 30/60 / 100
OPERATING VOLTAGE [V AC, Hz]	230, 50
POWER CONSUMPTION [W]	19,5
STANDBY [W]	0,8
SOUND PRESSURE LEVEL 30 m ³ /h, 2 m [dB(A)]	UP: 16, AP: 18
SOUND PRESSURE LEVEL 60 m ³ /h, 2 m [dB(A)]	UP: 27, AP: 31
SOUND PRESSURE LEVEL 100 m ³ /h, 2 m [dB(A)]	UP: 39, AP: 44
INGRESS PROTECTION / PROTECTION CLASS	IPX5 / II

Components

- Fan insert with fan, control electronics,
- G3 dust filter (ISO Coarse 50 %) and interior panel
- Optional: humidity and air quality sensor, second room connection, fire protection accessories
- Fan housing with leak-proof non-return damper
- Available housing variants:
 - Flush-mounted (UP) radial/axial
 - Flush-mounted (UP) Radial Fire protection
 - Surface-mounted (AP) Axial

Air volume flow / pressure curve

Taris 30/60 N(F), Radial outlet connection

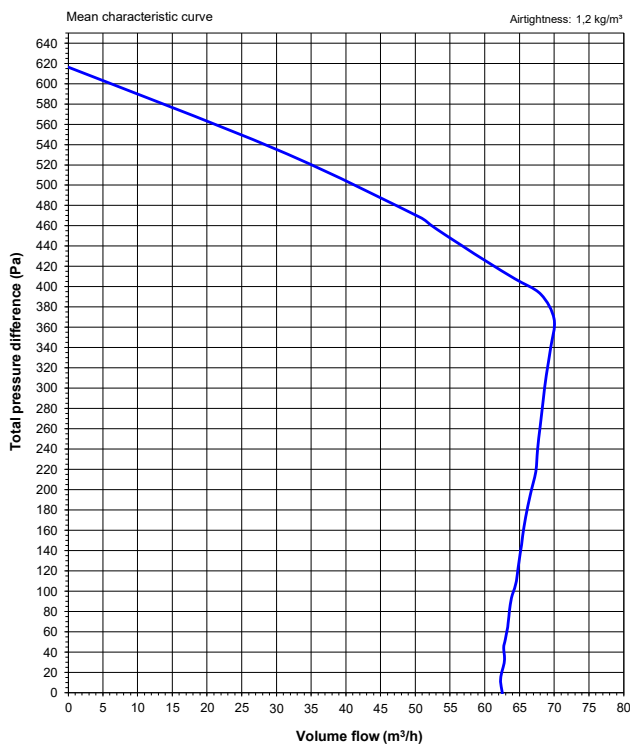

Taris 30/60 N(F), Axial outlet connection

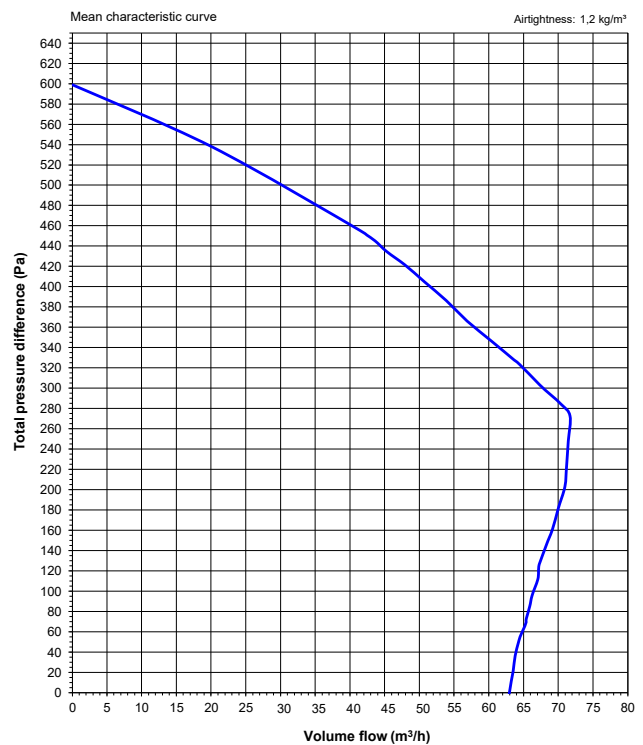

Notes on ventilation planning according to DIN 18017-3

Air volume flows

Systems for ventilating sanitary rooms such as bathrooms and toilets can be designed for the following minimum air volume flows (depending on the design and mode of operation):

40 m³/h: To ensure adequate ventilation, this air volume flow must be discharged over a period of at least 12 hours per day.

60 m³/h: The air volume flow can be reduced to 0 m³/h if it is ensured that a further 15 m³ of air is removed from the room to be ventilated via the ventilation unit or exhaust air valve after each switch-off.

In accordance with DIN 18017-3, the air volume flow can be up to 15 % below the scheduled volume flow if several ventilation units are operating simultaneously in the supply shaft and due to external influences.

Afterflow openings

For the extract air unit to function optimally and to avoid negative pressure in the room, it must be ensured that the extracted air volume of supply air can flow in.

Supply air: Each internal room to be ventilated must have a non-closable supply air opening with a free cross-section of at least 150 cm² to ensure a sufficient air supply.

Exhaust air: The exhaust air must be discharged into the riser pipe or directly to the outside as close to the ceiling as possible. In bathrooms, the exhaust air and supply air units must be positioned in such a way that no draughts (air volume flows above 0.2 m/s) occur in the occupied zone of the users.

The air outlet openings can be designed as a simple fresh air diffuser, e.g. aV100 ALD. From an energy point of view, it is advisable to provide ventilation units with heat recovery as downstream air vents.

Taris integration into central supply shafts (multi-storey)

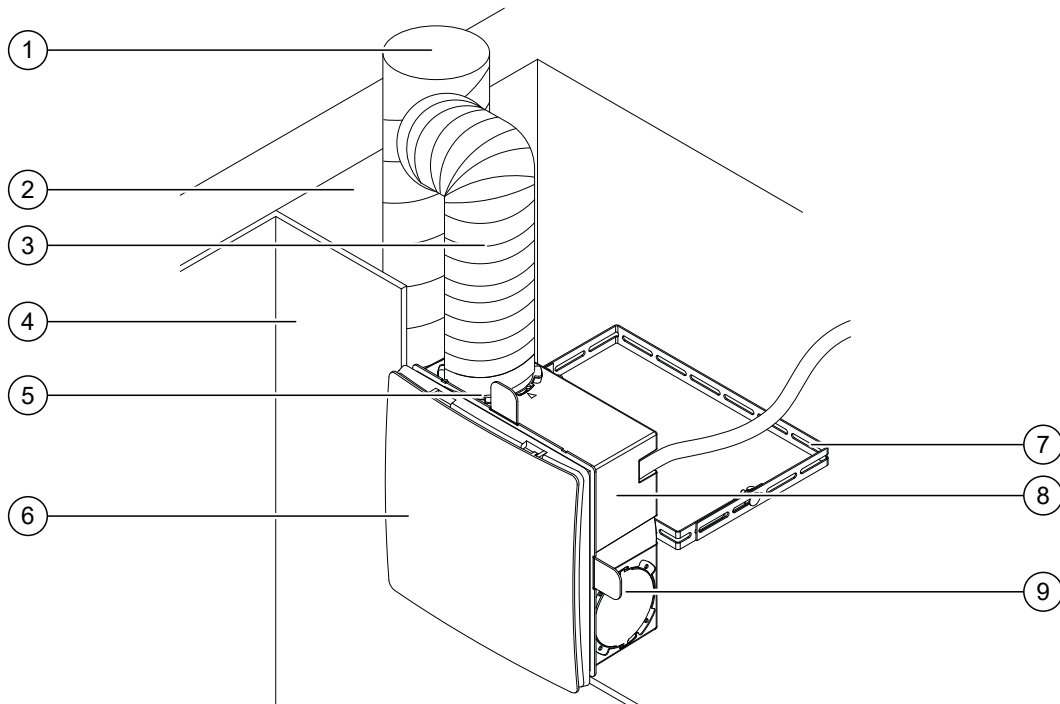

1 Riser pipe	4 Drywall	7 Mounting bracket
2 Shaft wall	5 Air outlet opening	8 Flush-mounted housing
3 Aluminium flexible pipe DN80	6 Inner cover	9 Optional connection 2nd room

If several exhaust air units are connected to one supply duct (line), observe the following requirements:

- Dimension the main duct so that all ventilation units can be operated simultaneously at full flow rate.
- Dimension the riser pipes including the necessary branch pieces and their diameter in accordance with the number of storeys and devices with the help of the line diagrams. Distortions, cross-sectional constrictions or a discharge pipe of more than 1.5 m above the topmost appliance lead to increased pressure losses. Compensate for this by increasing the diameter of the riser pipe.
- In accordance with DIN 18017-3, exhaust air ducts must be tight, stable and, if there are more than two full storeys, made of fire-resistant material (DIN 4102:A). They must be thermally insulated or designed to prevent damage from condensation. The exhaust pipe must lead over the roof.
- Secure the main pipe (supply shaft) with noise-damping pipe clamps to prevent structure-borne noise transmission. The design and installation of the ventilation systems must comply with the building acoustics requirements.
- Install cleaning openings with tight closures in the exhaust air ducts (connection hose) so that the exhaust air ducts can be cleaned easily. A sufficient number of cleaning openings must be ensured. Screw-in cleaning plugs are not permitted.
- Connect a maximum of two ventilation units per storey to a common supply duct.
- No other rooms in a flat may be connected to a ventilation unit that vents the bathroom and WC.
- The bending radius (R) when connecting to the pipe system must not be less than the pipe diameter (DN).

Line diagrams for dimensioning the riser pipes

Requirements: Storey height: 2.75 m | Roof exit: 1.50 m

The following tables show the correct dimensioning of the nominal riser pipe sizes depending on the number of building storeys and the number and output of the devices used.

Air volume flow 60 m³/h

2 exhaust air units per floor

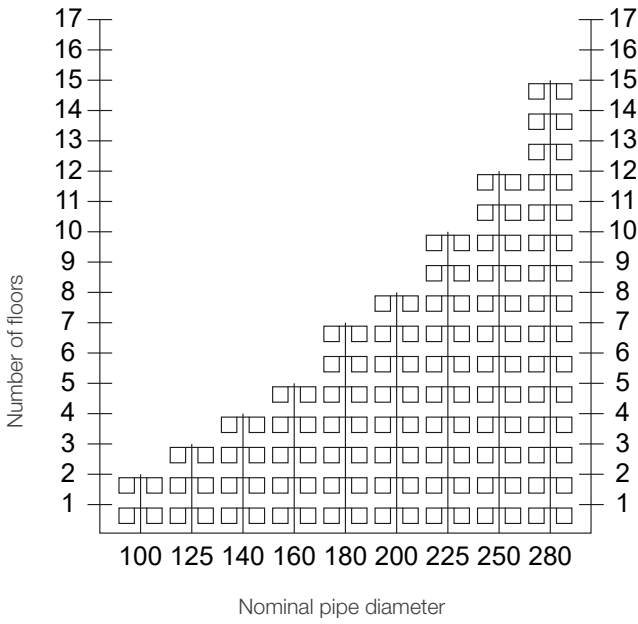

1 exhaust air unit per floor

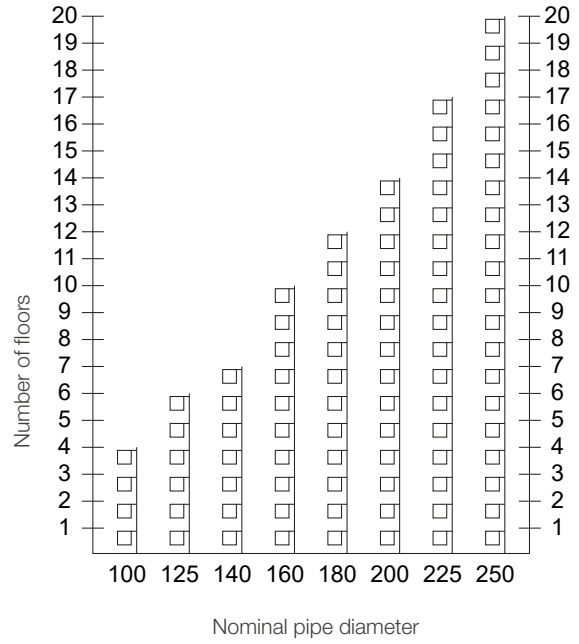

Air volume flow 100 m³/h

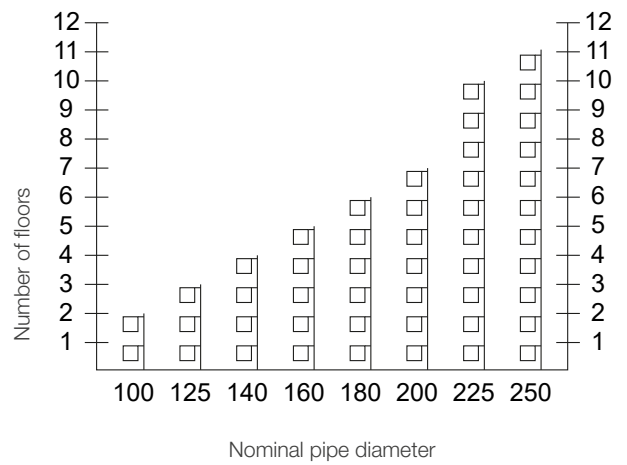
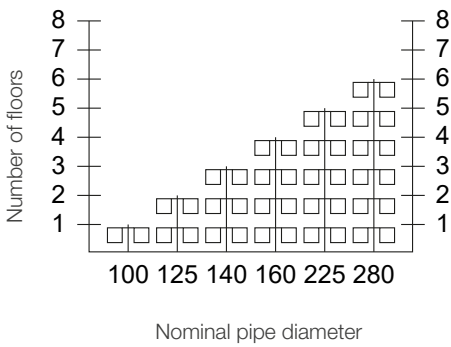

aV100 ALD air inlet



aV100 ALD complete system, interior view

Air inlet for passive supply air post-flow in decentralised exhaust air systems without heat recovery.

For new construction and renovation for easy integration into outer walls.

Quick installation with Simplex available.

Components

- ALD insert with insulated angled inner cover
- Filter cartridge with G1 dust filter (ISO Coarse) and wind protection
- Round wall mounting sleeve
- Weather protection grille with slat opening

Accessories (optional)

- G3 pollen filter (ISO Coarse), F7 flicker filter (ePM1 50%)
- D120 or Simplex R-D103 wall mounting block
- Soundproofing accessories

Technical specifications

MINIMUM WALL THICKNESS INCLUDING PLASTER [mm]	150
WALL OPENING DIAMETER [mm]	115
WALL MOUNTING SLEEVE DIAMETER [mm]	103
AIR VOLUME FLOW 4 Pa [m³/h]	7 – 15
AIR VOLUME FLOW 8 Pa [m³/h]	14 – 22
STANDARD SOUND LEVEL DIFFERENCE [dB] ¹	33 – 49
INNER COVER DIMENSIONS [W x H, mm]	160 x 160
DIMENSIONS OF WEATHER PROTECTION GRILLE [W x H, mm]	150 x 150

¹ Depending on sound insulation accessories

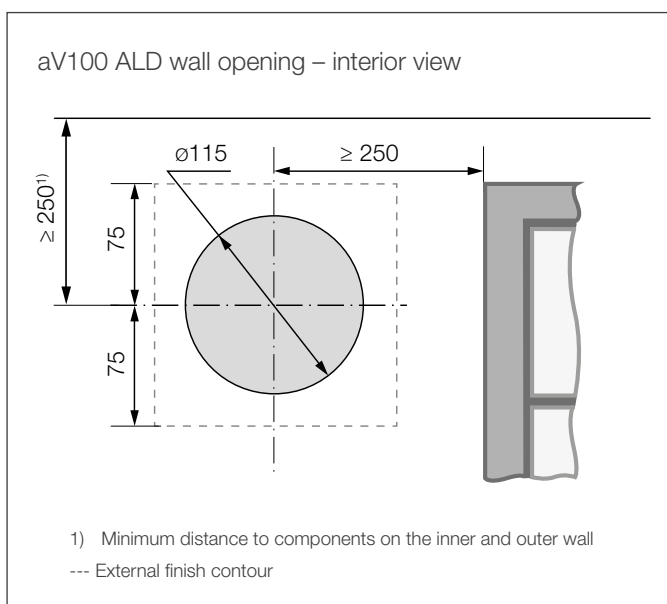

Resistance characteristic curve

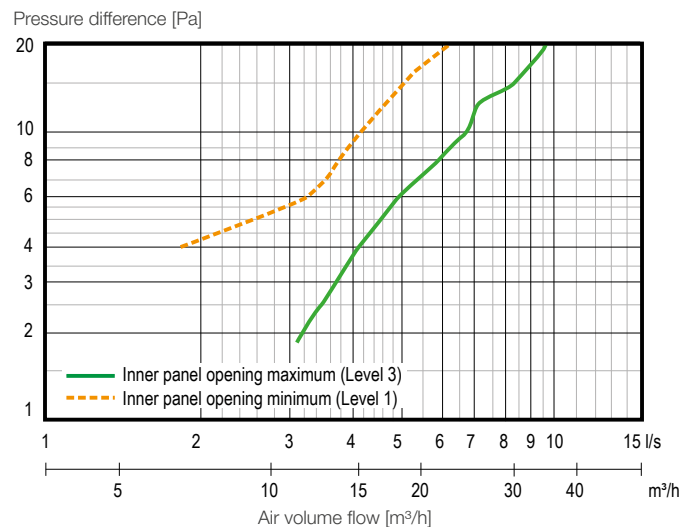

aV100 ALD Plus air inlet

Air inlet for passive supply air post-flow in decentralised exhaust air systems without heat recovery.

For new construction and renovation for easy integration into outer walls.

Quick installation with Simplex available.

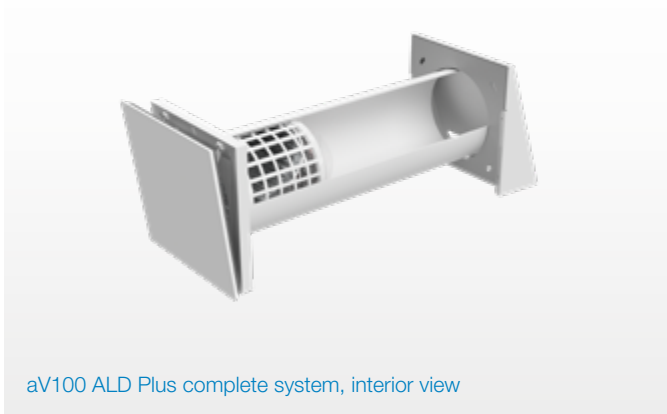

aV100 ALD Plus complete system, interior view

Components

- ALD insert with insulated angled inner cover
- Filter cartridge with G1 dust filter (ISO Coarse) and wind protection
- Round wall mounting sleeve
- Weather protection hood with protective grille (driving-rain-proof), available in white (RAL9016), grey (RAL9006), anthracite (RAL7016), and special RAL colours.

Accessories (optional)

- G3 pollen filter (ISO Coarse), F7 flicker filter (ePM1 50%)
- D120 or Simplex R-D103 wall mounting block
- Soundproofing accessories

Technical specifications

MINIMUM WALL THICKNESS INCLUDING PLASTER [mm]	150
WALL OPENING DIAMETER [mm]	115
WALL MOUNTING SLEEVE DIAMETER [mm]	103
AIR VOLUME FLOW 4 Pa [m³/h]	7 – 15
AIR VOLUME FLOW 8 Pa [m³/h]	14 – 22
STANDARD SOUND LEVEL DIFFERENCE [dB] ¹	34 – 48
INNER COVER DIMENSIONS [W x H, mm]	160 x 160
WEATHER PROTECTION HOOD DIMENSIONS [W x H, mm]	182 x 198

¹ Depending on sound insulation accessories

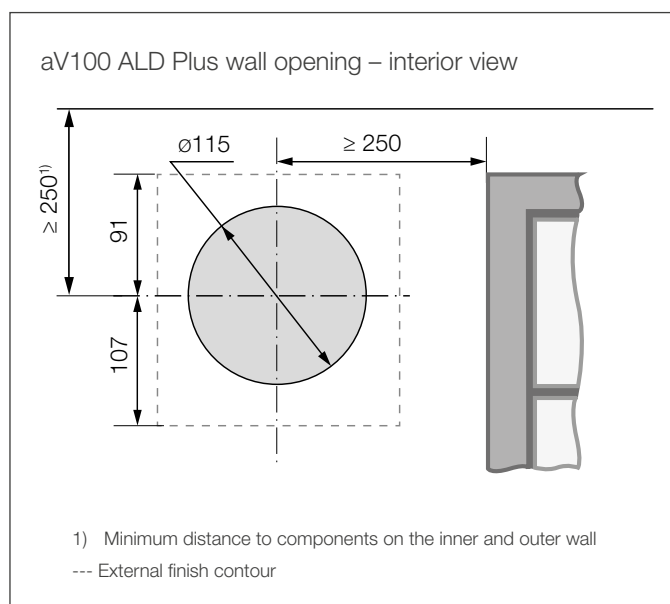

Resistance characteristic curve

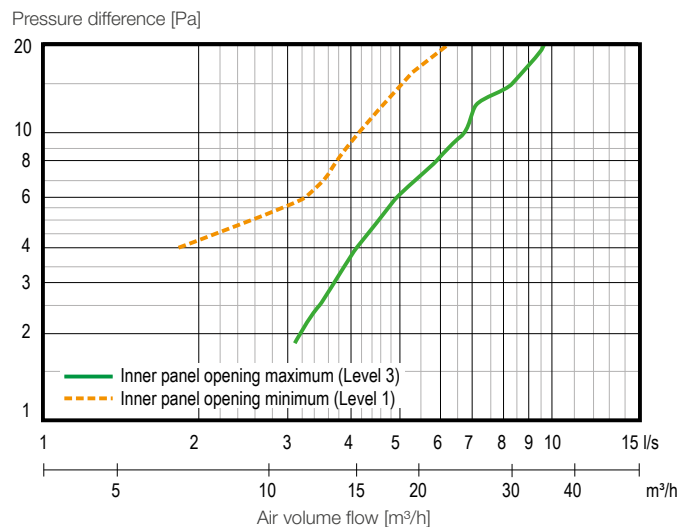

aV100 ALD Corner air inlet



aV100 ALD Corner complete system, interior view

Air inlet for passive supply air post-flow in decentralised exhaust air systems without heat recovery.

Corner duct with stainless steel grille as reveal variant for a concealed external finish.

For new construction and renovation for easy integration into outer walls.

Quick installation with Simplex available.

Components

- ALD insert with insulated angled inner cover
- Filter cartridge with G1 dust filter (ISO Coarse) and wind protection
- Round wall mounting sleeve
- Corner duct with stainless steel soffit grille, available in white (RAL9016), grey (RAL9006), and anthracite (RAL7016).

Accessories (optional)

- G3 pollen filter (ISO Coarse), F7 flicker filter (ePM1 50%)
- D120 or Simplex R-D103 wall mounting block
- D103 substructure board
- Sound insulation accessories

Technical specifications

MINIMUM WALL THICKNESS/INSULATION [mm]	> 150 / > 70
WALL OPENING DIAMETER [mm]	115
WALL MOUNTING SLEEVE DIAMETER [mm]	103
AIR VOLUME FLOW 4 Pa [m³/h]	7 – 15
AIR VOLUME FLOW 8 Pa [m³/h]	14 – 22
STANDARD SOUND LEVEL DIFFERENCE [dB] ¹	55 – 59
INNER COVER DIMENSIONS [W x H, mm]	160 x 160
REVEAL GRILLE DIMENSIONS [W x H, mm]	70 x 512

¹ Depending on sound insulation accessories

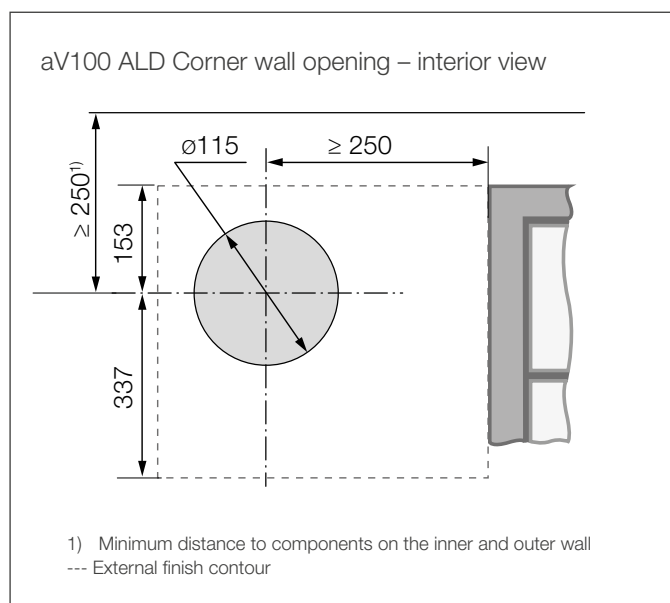

Resistance characteristic curve

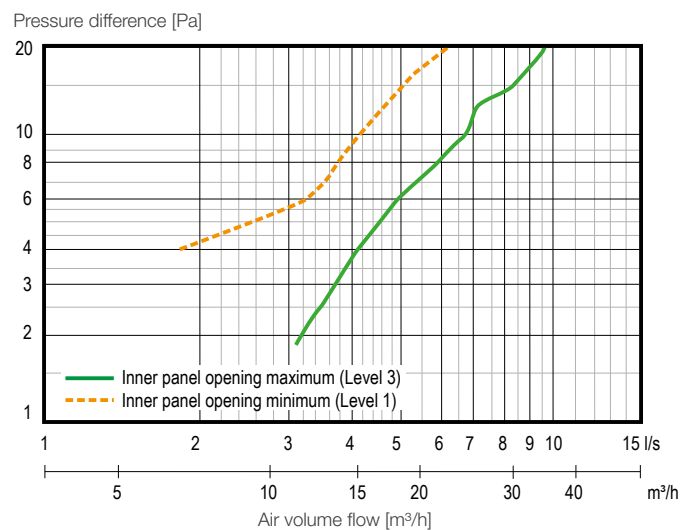

aV100 ALD Nordic air inlet

Air inlet for passive supply air post-flow in decentralised exhaust air systems without heat recovery.

For new construction and renovation with external finish flush with the facade for easy integration into clinker facades or outer walls with insulation.

Quick installation with Simplex available.

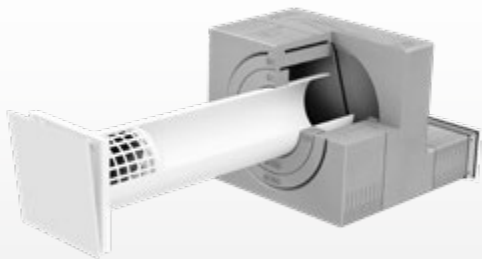

aV100 ALD Nordic complete system, interior view

Components

- ALD insert with insulated angled inner cover
- Filter cartridge with filter (ISO Coarse) and wind protection
- Round wall mounting sleeve
- Nordic facade end including outer grille, available in white (RAL9016), grey (RAL9006), anthracite (RAL7016), and copper brown (RAL8004)

Accessories (optional)

- G3 pollen filter (ISO Coarse), F7 flicker filter (ePM1 50%)
- D120 or Simplex R-D103 wall mounting block
- Soundproofing accessories

Technical specifications

WALL THICKNESS / INSULATION [mm]	> 130 / > 120
TOTAL CLINKER / THERMAL INSULATION SYSTEM WALL THICKNESS [mm]	> 365 / > 250
WALL OPENING DIAMETER [mm]	115
WALL MOUNTING SLEEVE DIAMETER [mm]	103
AIR VOLUME FLOW 4 Pa [m ³ /h]	7 – 15
AIR VOLUME FLOW 8 Pa [m ³ /h]	14 – 22
STANDARD SOUND LEVEL DIFFERENCE [dB] ¹	51 – 53
INNER COVER DIMENSIONS [W x H, mm]	160 x 160
OUTER GRILLE DIMENSIONS [W x H, mm]	290 x 89

¹ Depending on sound insulation accessories

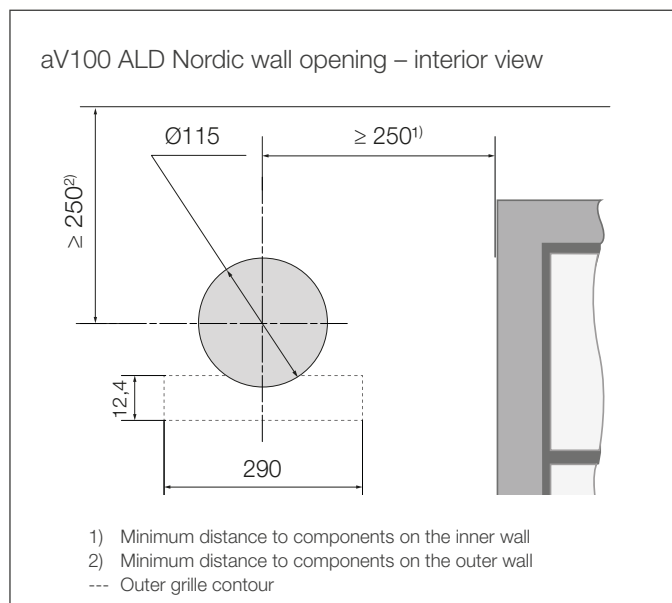

Resistance characteristic curve

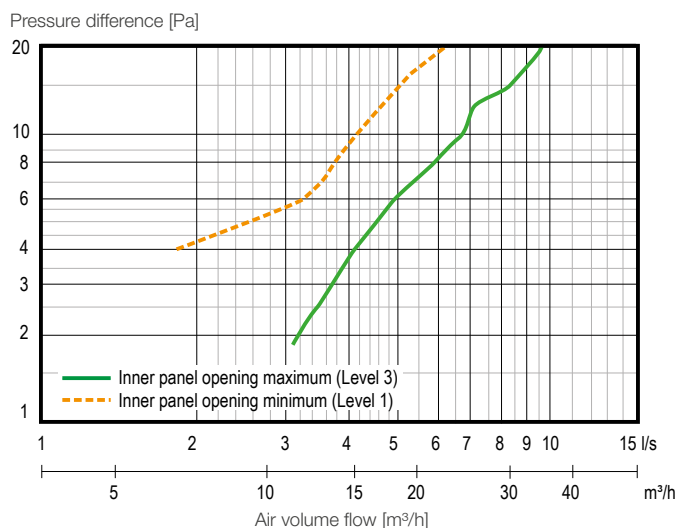

aV160 ALD Light air inlet



aV160 ALD Light complete system, interior view

Air inlet for passive supply air post-flow in decentralised exhaust air systems without heat recovery.

Sound-insulated variant for new construction and renovation for easy integration into outer walls.

Quick installation with Simplex available.

Can be subsequently upgraded to the iV-Light ventilation system (for wall thicknesses ≥ 290 mm).

Components

- Insulated angled inner cover, can be locked with a depressing movement. Stepped supply air regulation.
- Filter cartridge with G1 dust filter (ISO Coarse) and wind protection
- Round wall mounting sleeve \varnothing 160 with sound insulation lining
- Round weather protection grille with slat opening and mounting claw for quick mounting

Accessories (optional)

- G3 pollen filter (ISO Coarse)
- D180 or Simplex R-D160 wall mounting block

Technical specifications

MINIMUM WALL THICKNESS INCLUDING PLASTER [mm]	150
WALL OPENING DIAMETER [mm]	180
WALL MOUNTING SLEEVE DIAMETER [mm]	160
AIR VOLUME FLOW 4 Pa [m^3/h]	12 – 18
AIR VOLUME FLOW 8 Pa [m^3/h]	18 – 24
STANDARD SOUND LEVEL DIFFERENCE [dB]	51 – 52
INNER COVER DIMENSIONS [W x H, mm]	220 x 220
WEATHER PROTECTION GRILLE DIMENSIONS [\varnothing , mm]	200

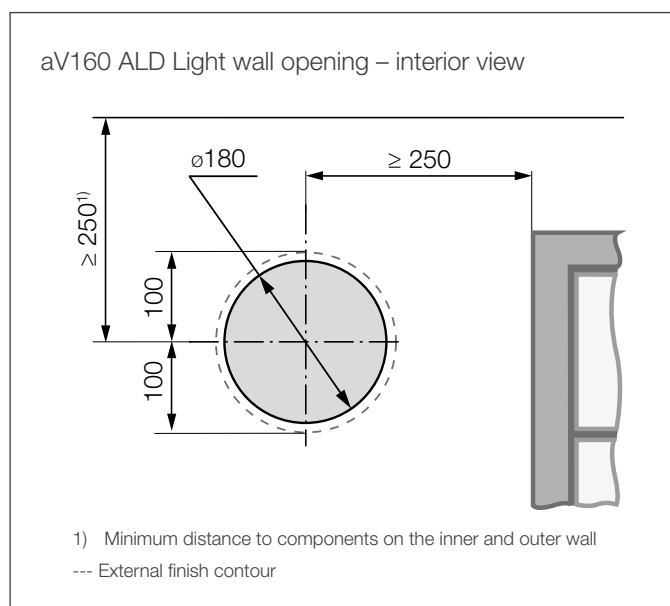

Resistance characteristic curve

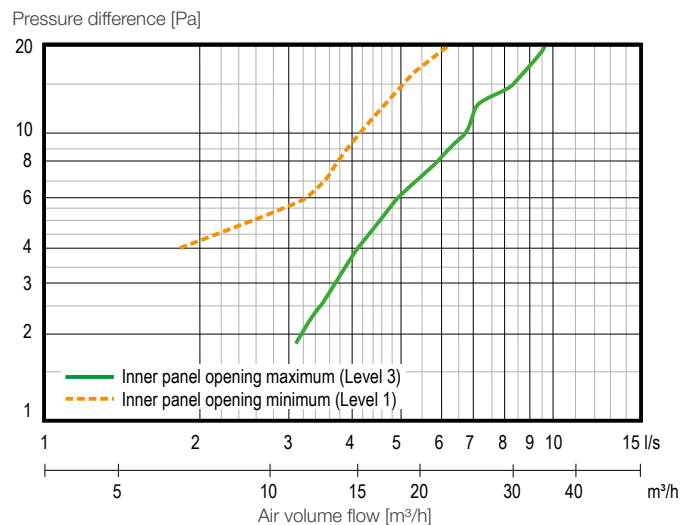

aV160 ALD Plus air inlet



aV160 ALD Plus complete system, interior view

Air inlet for passive supply air post-flow in decentralised exhaust air systems without heat recovery.

Sound-insulated variant for new construction and renovation for easy integration into outer walls.

Quick installation with Simplex available.

Can be subsequently upgraded to the iV-Smart+ ventilation system (for wall thicknesses ≥ 270 mm).

Components

- Insulated angled inner cover, can be locked with a depressing movement. Stepped supply air regulation.
- Filter cartridge with G1 dust filter (ISO Coarse) and wind protection
- Round wall mounting sleeve $\varnothing 160$ with sound insulation lining
- Weather protection hood with protective grille (driving-rain-proof), available in white (RAL9016), grey (RAL9006), and anthracite (RAL7016).

Accessories (optional)

- G3 pollen filter (ISO Coarse)
- D180 or Simplex R-D160 wall mounting block

Technical specifications

MINIMUM WALL THICKNESS INCLUDING PLASTER [mm]	150
WALL OPENING DIAMETER [mm]	180
WALL MOUNTING SLEEVE DIAMETER [mm]	160
AIR VOLUME FLOW 4 Pa [m^3/h]	13 – 17
AIR VOLUME FLOW 8 Pa [m^3/h]	19 – 23
STANDARD SOUND LEVEL DIFFERENCE [dB]	54 – 55
INNER COVER DIMENSIONS [W x H, mm]	220 x 220
WEATHER PROTECTION HOOD DIMENSIONS [W x H, mm]	279 x 313

aV160 ALD Plus wall opening – interior view

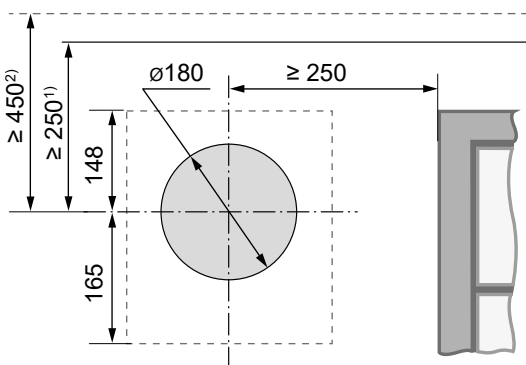

- 1) Minimum distance to components on the inner wall
 - 2) Minimum distance to adjacent components on the outer wall
- External finish contour

Resistance characteristic curve

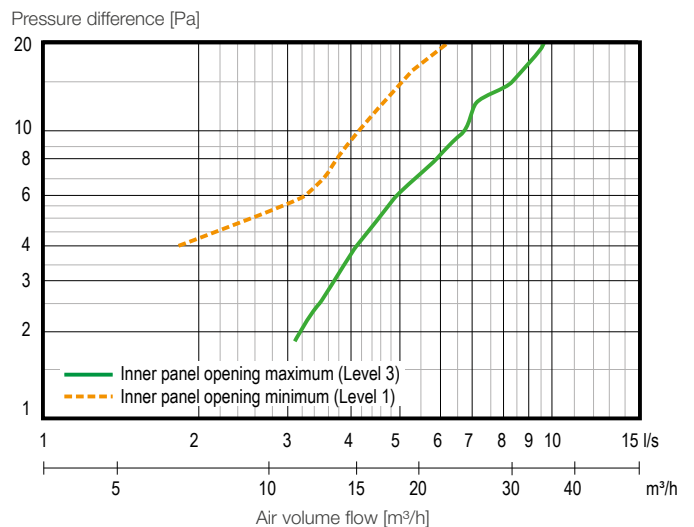

aV160 ALD Corner air inlet



aV160 ALD Corner complete system, interior view

Air inlet for passive supply air post-flow in decentralised exhaust air systems without heat recovery.

Sound-insulated variant for new construction and renovation for easy integration into outer walls. Corner duct with stainless steel grille as reveal variant for a concealed external finish.

Quick installation with Simplex available.

Can be subsequently upgraded to the iV-Smart+ ventilation system (for wall thicknesses ≥ 270 mm).

Components

- Insulated angled inner cover, can be locked with a depressing movement. Stepped supply air regulation.
- Filter cartridge with G1 dust filter (ISO Coarse) and wind protection
- Round wall mounting sleeve $\varnothing 160$ with sound insulation lining
- Corner duct with stainless steel soffit grille, available in white (RAL9016), grey (RAL9006), and anthracite (RAL7016).

Accessories (optional)

- G3 pollen filter (ISO Coarse)
- D103 substructure board
- D180 or Simplex R-D160 wall mounting block

Technical specifications

MINIMUM WALL THICKNESS / INSULATION [mm]	> 150 / > 70
WALL OPENING DIAMETER [mm]	180
WALL MOUNTING SLEEVE DIAMETER [mm]	160
AIR VOLUME FLOW 4 Pa [m^3/h]	12 – 18
AIR VOLUME FLOW 8 Pa [m^3/h]	18 – 24
STANDARD SOUND LEVEL DIFFERENCE [dB]	61
INNER COVER DIMENSIONS [W x H, mm]	220 x 220
REVEAL GRILLE DIMENSIONS [W x H, mm]	70 x 512

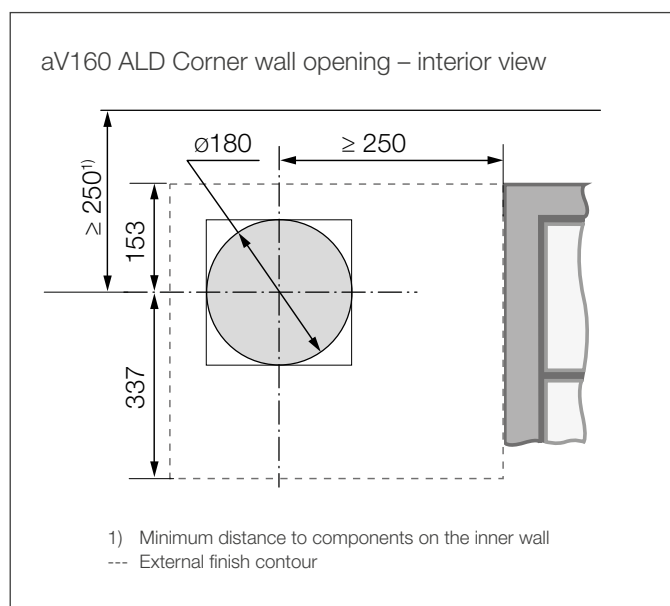

Resistance characteristic curve

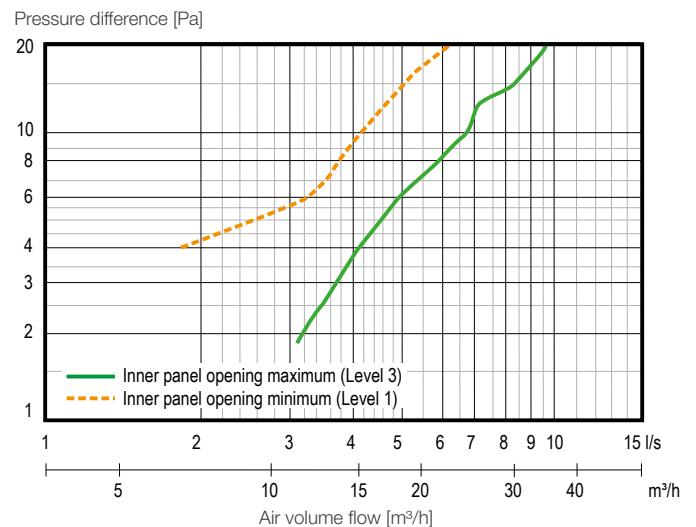

aV160 ALD Nordic air inlet

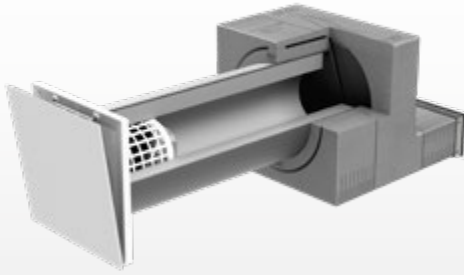

aV160 ALD Nordic complete system, interior view

Air inlet for passive supply air post-flow in decentralised exhaust air systems without heat recovery.

For new construction and renovation with external finish flush with the facade for easy integration into clinker facades or outer walls with insulation.

Quick installation with Simplex available.

Can be subsequently upgraded to the iV-Smart+ ventilation system (for wall thicknesses ≥ 270 mm).

Components

- Insulated angled inner cover, can be locked with a depressing movement. Stepped supply air regulation.
- Filter cartridge with filter (ISO Coarse) and wind protection
- Round wall mounting sleeve $\varnothing 160$ with sound insulation lining
- Nordic facade end including outer grille, available in white (RAL9016), grey (RAL9006), anthracite (RAL7016), and copper brown (RAL8004)

Accessories (optional)

- G3 pollen filter (ISO Coarse)
- D180 or Simplex R-D160 wall mounting block

Technical specifications

WALL THICKNESS / INSULATION [mm]	> 130 / > 120
TOTAL CLINKER / THERMAL INSULATION SYSTEM WALL THICKNESS [mm]	> 365 / > 250
WALL OPENING DIAMETER [mm]	180
WALL MOUNTING SLEEVE DIAMETER [mm]	160
AIR VOLUME FLOW 4 Pa [m^3/h]	12 – 18
AIR VOLUME FLOW 8 Pa [m^3/h]	18 – 24
STANDARD SOUND LEVEL DIFFERENCE [dB]	52
INNER COVER DIMENSIONS [W x H, mm]	220 x 220
OUTER GRILLE DIMENSIONS [W x H, mm]	290 x 89

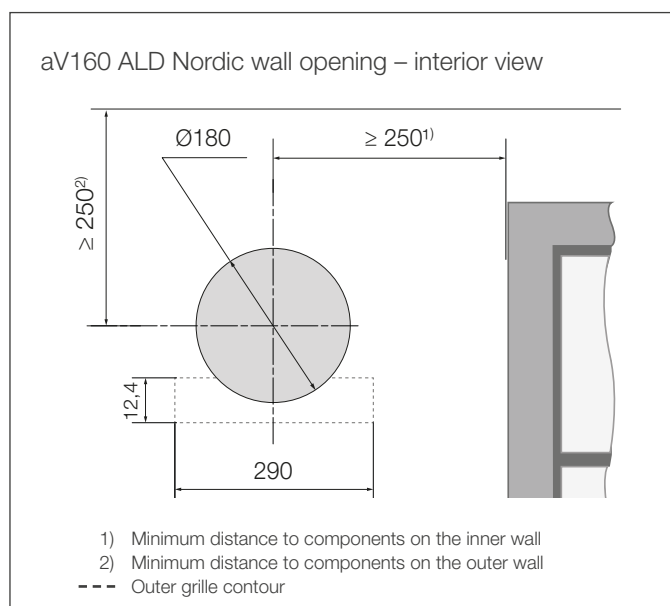

Resistance characteristic curve

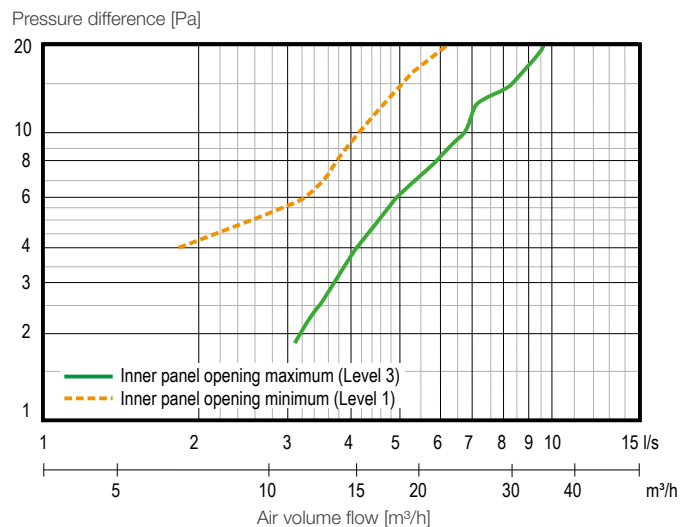

aV200 ALD air inlet



aV200 ALD complete system exterior view

Air inlet for passive supply air post-flow in decentralised exhaust air systems without heat recovery.

Sound-insulated variant for new construction and renovation for easy integration into outer walls.

Quick installation with Simplex available.

Can be subsequently upgraded to the iV14-Zero ventilation system (for wall thicknesses ≥ 255 mm).

Components

- Insulated angled inner cover, can be locked with a depressing movement
- Filter cartridge with G1 dust filter (ISO Coarse) and wind protection
- Round wall mounting sleeve \varnothing 200 with double sound insulation lining (Inventin® and additional sound insulation)
- Driving-rain-proof weather protection hood

Accessories (optional)

- G3 pollen filter (ISO Coarse)
- D230 or Simplex R-D200 wall mounting block

Technical specifications

MINIMUM WALL THICKNESS INCLUDING PLASTER [mm]	150
WALL OPENING DIAMETER [mm]	225
WALL MOUNTING SLEEVE DIAMETER [mm]	200
AIR VOLUME FLOW 4 Pa [m^3/h]	17
AIR VOLUME FLOW 8 Pa [m^3/h]	26
STANDARD SOUND LEVEL DIFFERENCE [dB]	55
INNER COVER DIMENSIONS [W x H, mm]	233 x 233
WEATHER PROTECTION HOOD DIMENSIONS [W x H, mm]	279 x 313

aV200 ALD wall opening – interior view

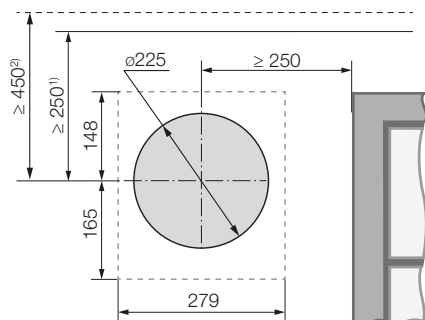

- 1) Minimum distance to components on the inner wall
 - 2) Minimum distance to components on the outer wall
- External finish contour

aV200 ALD external cover:
Flex weather protection hood

White: RAL9016
Grey: RAL9006
Anthracite: RAL7016

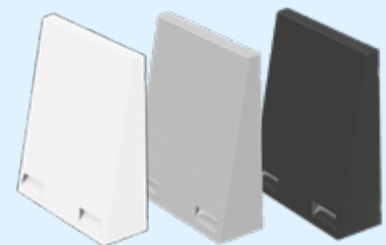

aV200 ALD internal cover:
Flair inner cover
(RAL9010)



aV200 ALD Corner air inlet



aV200 ALD Corner complete system exterior view

Air inlet for passive supply air post-flow in decentralised exhaust air systems without heat recovery.

Sound-insulated variant for new construction and renovation as reveal variant with concealed external finish for easy integration into outer walls with insulation.

Quick installation with Simplex available.

Can be subsequently upgraded to the iV14-Zero Corner ventilation system (for wall thicknesses ≥ 270 mm and insulation thickness ≥ 70 mm).

Components

- Insulated angled inner cover, can be locked with a depressing movement
- Filter cartridge with G1 dust filter (ISO Coarse) and wind protection
- Round wall mounting sleeve $\varnothing 200$ with double sound insulation lining (Inventin® and additional sound insulation)
- Corner flat duct including soffit grille

Accessories (optional)

- G3 pollen filter (ISO Coarse)
- D230 or Simplex R-D200 wall mounting block

Technical specifications

MINIMUM WALL THICKNESS / INSULATION [mm]	150/70
WALL OPENING DIAMETER [mm]	225
WALL MOUNTING SLEEVE DIAMETER [mm]	200
AIR VOLUME FLOW 4 Pa [m^3/h]	17
AIR VOLUME FLOW 8 Pa [m^3/h]	26
STANDARD SOUND LEVEL DIFFERENCE [dB]	54
INNER COVER DIMENSIONS [W x H, mm]	233 x 233
REVEAL GRILLE DIMENSIONS [W x H, mm]	70 x 527

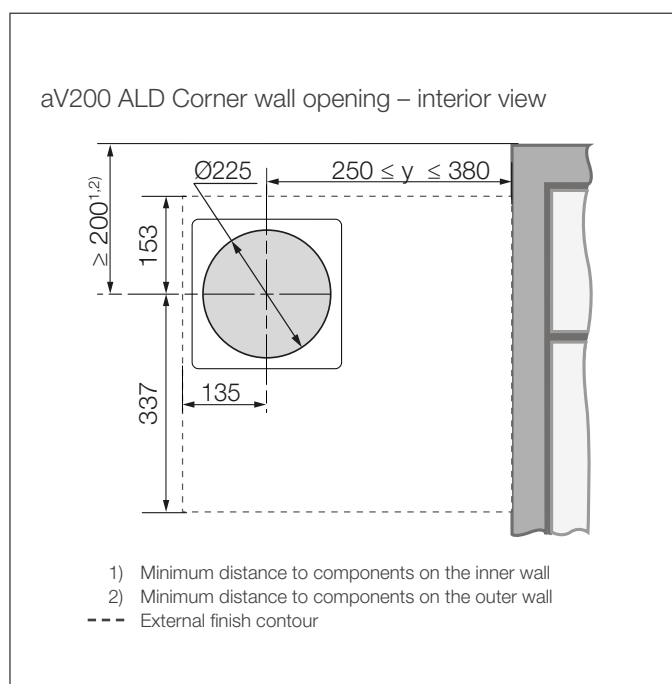

aV200 ALD Corner external cover:
Reveal grille

White: RAL9016
Grey: RAL9006
Anthracite: RAL7016

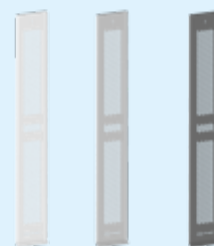

aV200 ALD internal cover:
Flair inner cover
(RAL9010)



aV200 ALD Nordic air inlet

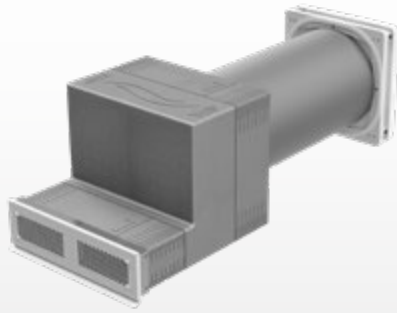

aV200 ALD Nordic complete system exterior view

Air inlet for passive supply air post-flow in decentralised exhaust air systems without heat recovery.

Sound-insulated variant for new construction and renovation with external finish flush with the facade for easy integration into clinker facades or outer walls with insulation.

Quick installation with Simplex available.

Can be subsequently upgraded to the iV14-Zero Nordic ventilation system (for wall thicknesses ≥ 250 mm, insulation thicknesses ≥ 120 mm including any gap).

Components

- Insulated angled inner cover, can be locked with a depressing movement
- Filter cartridge with G1 dust filter (ISO Coarse) and wind protection
- Round wall mounting sleeve $\varnothing 200$ with double sound insulation lining (Inventin® and additional sound insulation)
- Nordic facade end (including outer grille)

Accessories (optional)

- G3 pollen filter (ISO Coarse)
- D230 or Simplex R-D200 wall mounting block

Technical specifications

WALL THICKNESS / INSULATION [mm]	>150 / >120
TOTAL CLINKER / THERMAL INSULATION SYSTEM WALL THICKNESS [mm]	> 385 / > 270
WALL OPENING DIAMETER [mm]	225
WALL MOUNTING SLEEVE DIAMETER [mm]	200
AIR VOLUME FLOW 4 Pa [m^3/h]	17
AIR VOLUME FLOW 8 Pa [m^3/h]	26
STANDARD SOUND LEVEL DIFFERENCE [dB]	56
INNER COVER DIMENSIONS [W x H, mm]	233 x 233
OUTER GRILLE DIMENSIONS [W x H, mm]	290 x 89

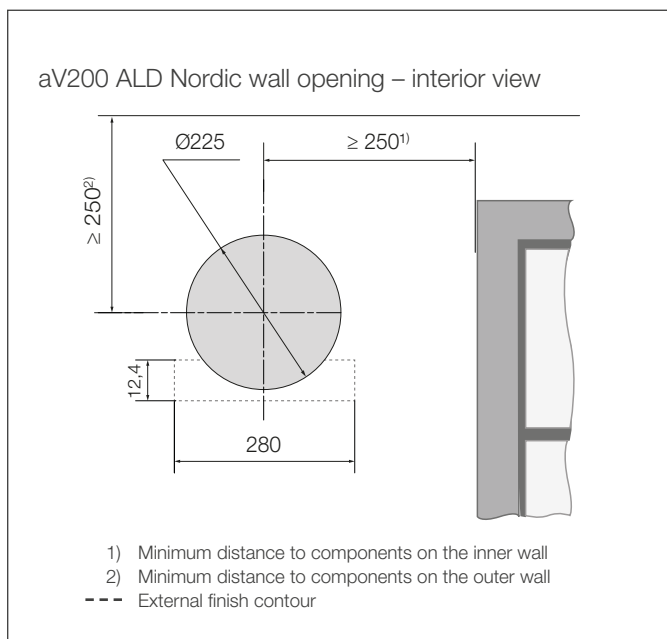

aV200 ALD Nordic external cover:
Outer grille

White: RAL9016
 Grey: RAL9006
 Anthracite: RAL7016
 Copper brown: RAL8004

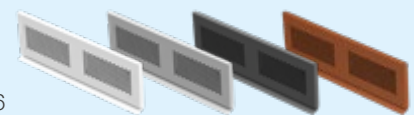

Internal cover
 aV200 ALD Nordic:
 Flair inner cover (RAL9010)





Accessories

for inVENTer products



Replacement filters

Dust filters (standard: included with all inner covers)



for IB Flair, Flair XL
(washable, class G4 /
ISO Coarse 60 %)

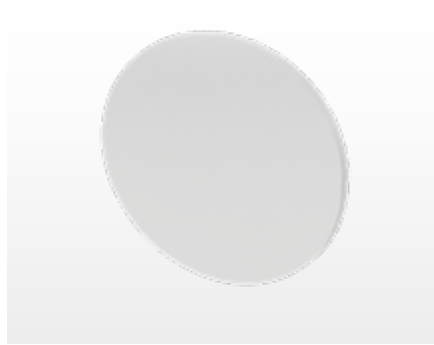

for IB Connect
(washable, class G3 /
ISO Coarse 45 %)



for IB Connect Office/MaxAir
(washable, class G4 /
ISO Coarse 60 %)



for iV-Twin+ / Connect
(washable, class G3 /
ISO Coarse 45 %)



for IB Light
(washable, class G4 /
ISO Coarse 60 %)

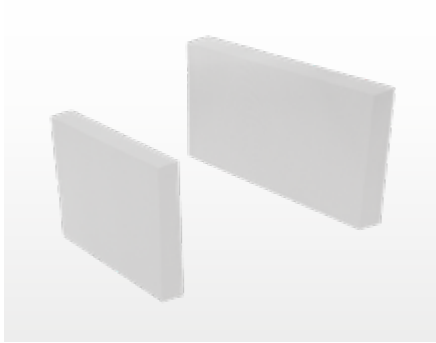

for inVENTer PAX (filter set)
(washable, class G4 /
ISO Coarse)



for Aventus / secondary room
(washable, class G2 /
ISO Coarse 30 %)



for aV100 ALD / aV160 ALD
(washable, class G1
ISO Coarse)

Pollen filters (for pollen season)



For IB Flair, Flair XL
(disposable filter, class F5 /
ISO Coarse 75%)



For IB Connect
(disposable filter, class F5 /
ISO Coarse 75%)



For iV-Twin+
(disposable filter, class F5 /
ISO Coarse 75%)



For aV100 ALD/aV160 ALD
(disposable filter, class G3 /
ISO Coarse)

Activated carbon filters (neutralise odours and pollutants)

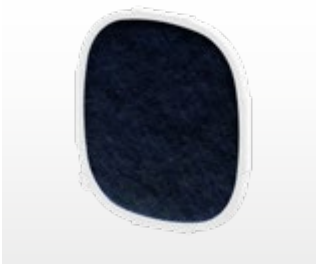

For IB Flair, Flair XL
(disposable filter, activated
carbon content: 100 g/m²)



For IB Connect
(disposable filter, activated
carbon content: 100 g/m²)



For iV-Twin+
(disposable filter, activated
carbon content: 100 g/m²)

Flicker filter



For aV100 ALD
(disposable filter, class F7 /
ePM1 50%)

Hygiene filter



For insertion into wall sleeve.
Suitable for ventilation
systems from the iV-Smart+,
iV14-Zero range.
Note: Reduction of the AVF
by approx. 15 %.
(disposable filter, class F7 /
ePM1 50 %, Ø 160 mm)

Sound insulation

Sound-insulating insert

For reducing external noise.
Special foam as insert in wall mounting sleeve.
Installation depth: + 165 mm

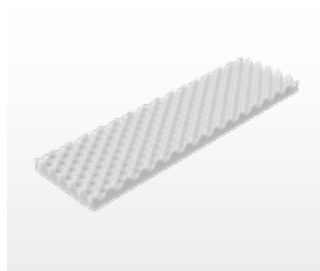

For iV ventilation systems with WEH Ø D160, D200, D250

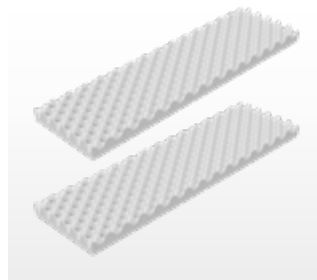

For iV-Twin+ ventilation systems



For aV100 ALD

Sound protector

Insulating element for reducing external and fan noise by deflecting the air volume flow.
Installation in wall mounting sleeve.

Installation depth:
+ 61 mm (R-D160) or
+ 76 mm (R-D200 and iV-Twin+)



R-D160 for iV-Smart+, iV14-Zero, iV-Light



R-D200 for iV14-MaxAir, iV-Office



For iV-Twin+ ventilation systems

Windbreak

Windbreak insert

Additional security against strong winds for exposed locations. Installation in wall mounting sleeve.

Installation depth:
+ 85 mm (R-D100) or
+ 110 mm (R-160) or
+ 132 mm (R-D200)



R-D100 for aV100



R-D160 for iV-Smart+, iV14-Zero, iV-Light



R-D200 for iV-Office, iV14-MaxAir

Sockets for controllers

Wall-mounted socket 70 x 87



For sMove s4 and s8 controllers, Ø 70 mm, depth 87 mm.

Flush-mounted socket 60x90



For sMove s4 controller, Ø 60 mm, depth 90 mm.

Flush-mounted socket 60x66



For sMove s4 and s8 controllers, MZ-Home, Easy Connect e16, Ø 60 mm, depth 66 mm.

Dry wall socket 68 x 61



For sMove s4 and s8 controllers, MZ-Home, Easy Connect e16, Ø 68 mm, depth 61 mm.

Sensors

inVENTer Connect radio sensors

FTS19 interior humidity/temperature sensor (868 MHz)



Radio sensor for monitoring humidity values within a ventilation zone. Allows needs-based ventilation guided by humidity. The sensor is battery-powered (2 x AAA) and needs no external power supply.

Measured values: Relative humidity (rF) and room temperature | Measurement range: 20 – 90% and 0 – 60 °C.

Sensor housing 60 x 60 x 22 mm (W x H x D). Surface mounting.

Radio network range: Open field: 100 m / Building: 20 m.

FTS19 exterior humidity/temperature sensor (868 MHz)



Radio sensor for communicating outdoor temperature. Needed for full controller platform functionality (summer operation and basement ventilation with dew point control). The sensor is battery-powered (2 x AAA) and needs no external power supply. To be mounted with northward orientation on the outer wall.

Measured values: Outdoor temperature and humidity | Measurement range: -20 – 60 °C and 20 – 90%.

Sensor housing 112 x 115 x 40 mm (W x H x D). Surface mounting. Ingress protection IP66.

Radio network range: Open field: 100 m / Building: 20 m.

CS2 CO₂ sensor (868 MHz)



Radio sensor for monitoring carbon dioxide and humidity values within a ventilation zone. Allows needs-based ventilation guided by carbon dioxide and humidity to ensure optimal ambient air quality.

Measured values: Carbon dioxide (CO₂) concentration, relative humidity (rF), and room temperature

Measurement range: 400 – 10,000 ppm, 20% – 90%, and 7 – 37 °C | Sensor housing 90 x 90 x 17 mm (W x H x D). Surface mounting. | Radio network range: Open field: 100 m / Building: 20 m.

SK19 switching contact (868 MHz)



Radio interface for integrating safety devices when the ventilation system is operated at the same time as fireplaces. The switching contact transmits the signal from a safety device (such as a ZP4 smoke exhaust monitor) to the system, allowing pressure compensation as necessary.

Sensor housing 90 x 90 x 17 mm (W x H x D). Surface mounting.

Radio network range: Open field: 100 m / Building: 20 m.

Other sensors



HYG12 hygrostat

External room hygrostat for automatic regulation of humidity. Extension of the basic controllers sMove s4 and sMove s8 / in connection with the exhaust fans Aventus and Avio N 100. Adjustment of the limit value by means of a setpoint wheel.

Sensor housing 81 x 81 x 28 mm (WxH x D). Surface mounting.



Hygrostat HYG18

External room hygrostat for automatic regulation of humidity. Digital display to show the relative room humidity and temperature. Extension of the sMove s4 and sMove s8 basic controllers. Limit values and switching hysteresis set with the rotary knob.

Sensor housing 81 x 81 x 29 mm (WxH x D). Surface mounting.



CS1 CO₂ sensor

Room sensor for background monitoring of carbon dioxide values for extended assurance of indoor air quality. Extension of the sMove s4 and sMove s8 basic controllers/ extension of the MZ-Home controller's automatic control function within a ventilation zone (connection to the corresponding Clust-Air® module).

Measured value: Carbon dioxide (CO₂) | Measurement range: 0 – 2,000 ppm | NDIR sensor measuring method
Sensor housing 84.5 x 84.5 x 25 mm (WxH x D). Surface mounting.



ZP4 version

Chimney guard ZP4

A safety device that enables a ventilation system to be operated simultaneously with a room air-dependent fireplace. Extension for inVENTer controllers. With temperature sensor and smoke tube adapter.

Measured parameter: Differential pressure

Measurement method: Differential pressure determination from 45 °C (furnace heated)

- Sensor housing ZP4 UP 160 x 160 x 70 mm (W x H x D) (flush-mounted version)
- Sensor housing ZP4 165 x 165 x 70 mm (W x H x D) (dry wall version)
- Sensor housing ZP4 Plus UP 180 x 180 x 65 mm (W x H x D) (flush-mounted version with touch display)
- Front panel 180 x 180 mm (W x H)



ZP4 Plus version

Warranty overview

Starting 1/1/2016

inVENTer stands for innovative, high-quality decentralised residential ventilation. Should we fall short of this standard, you can report your complaint in writing by e-mail to service.export@inventer.de. Remember to describe the detected defects as precisely as possible (photo/video as applicable and possible).

Our service team will process your concerns and contact you as soon as possible.

All defects detected within 2 years from the date of the delivery note are subject to warranty:

- After the customer has made a complaint, inVENTer will immediately deliver a new spare part.
- The rejected material may only be returned for inspection after consultation with inVENTer; please be sure to enclose the "Complaint form export".
- The shipping costs will be refunded against proof in the case of justified complaints.
- Should an agreed return delivery of the defective material be missed within the reminder or dunning period, inVENTer reserves the right to charge the costs for the spare part already delivered in advance.
- The costs for the replacement of devices will only be covered by inVENTer after a decision has been made on a case-by-case basis; if necessary, a cost estimate will be requested.

All electronic devices are additionally covered by the inVENTer manufacturer's warranty of 5 years:

- Defective electronic devices that are detected within 2-5 years from the date of the delivery note are to be sent to inVENTer for inspection after notification of the complaint and only after consultation.
- The shipping costs will be refunded against proof in the case of justified complaints.
- inVENTer will check the returned material as fast as possible. In the case of justified complaints, the rejected part will be repaired or an equivalent replacement will be delivered. In the case of unaccepted complaints, there is the alternative of purchasing new or B-goods.
- The costs for the replacement of devices will only be covered by inVENTer after a decision has been made on a case-by-case basis; if necessary, a cost estimate will be requested.
- The inVENTer manufacturer's warranty applies exclusively to inVENTer brand products. Products from other manufacturers purchased through inVENTer are excluded. For these, the manufacturer's complaint conditions apply.

The ceramic unit of the ventilation system (thermal accumulator) is additionally covered by the inVENTer manufacturer's warranty of 30 years:

- After notification of a complaint (within 2-30 years from the date of the delivery note) and a prior inspection (proof of picture), a replacement part will be delivered immediately; it is not necessary to return the defective thermal accumulator.
- If no picture evidence is available or if it is not clear, the thermal accumulator (after consultation) shall be sent to inVENTer for inspection. In the case of an accepted complaint, a replacement of equal quality will be supplied immediately.
- The shipping costs will be refunded against proof in the case of justified complaints.

Contact person

Our central service department is your point of contact for the inVENTer manufacturer warranty or guarantee:

inVENTer GmbH

Technical Service Department

Ortsstrasse 4a

D-07751 Löberschütz, Germany

Phone: +49 (0) 36427 211-333

Email: service@inventer.de

www.inventer.de/garantie

inVENTer GmbH
Ortsstraße 4a
D-07751 Löberschütz
Phone: +49 (0) 36427 211-0
Fax: +49 (0) 36427 211-113
E-Mail: info@inventer.de
Web: www.inventer.eu

